



**Planning and Zoning
Department**

616 Germantown Pike, Lafayette
Hill, PA 19444-1821

484-594-2625

www.whitemarshTWP.org

Subdivision and Land Development Cover
Page for SLD # 01-22

Project Name: 931 Spring Mill Avenue, LLC

Address: 927-31 Spring Mill Avenue

Date: January 5, 2022

Status: Conditional Preliminary Land
Development Approved 4.14.2022

Updates:

Montgomery County Planning Commission Review - February 3, 2022

Zoning Ordinance Compliance Review Letter - February 3, 2022

Township Engineer Review Letter - February 4, 2022

Revised Site Plan - March 4, 2022

Waiver Request Letter - March 4, 2022 - SUPERSEDED

Waiver Request Letter - Revised March 15, 2022

Reviews Response Letter - March 15, 2022

Shade Tree Commission Memo - April 6, 2022

Cornerstone
Consulting Engineers & Architectural, Inc.

Pennsylvanian Region
570-859-1770

213 West Main Street, Lansdale, PA 19446
Phone: 215-362-2600, Fax: 215-362-8400
WWW.CORNERSTONEINC.COM

Philadelphia Region
215-502-2600

Table with 2 columns: NO, BY, DESCRIPTION, DATE. Includes a 'REVISIONS' section.

PENNSYLVANIA ONE CALL SYSTEM, INC. 925 Iron Run Road West Mifflin, Pennsylvania 15122-1078

BEFORE YOU DIG ANYWHERE IN PENNSYLVANIA CALL 1-800-242-1776

J.B. ANDERSON
PROFESSIONAL ENGINEER
931 SPRING MILL AVENUE, LLC
927-31 SPRING MILL AVENUE
WHITEMARSH TOWNSHIP
MONTGOMERY COUNTY
COMMONWEALTH OF PENNSYLVANIA

Table with 2 columns: PROJ. #, DATE, CAD ID, DRN BY, SCALE, CHK BY, SHEET 1 OF 10, REVISION #.

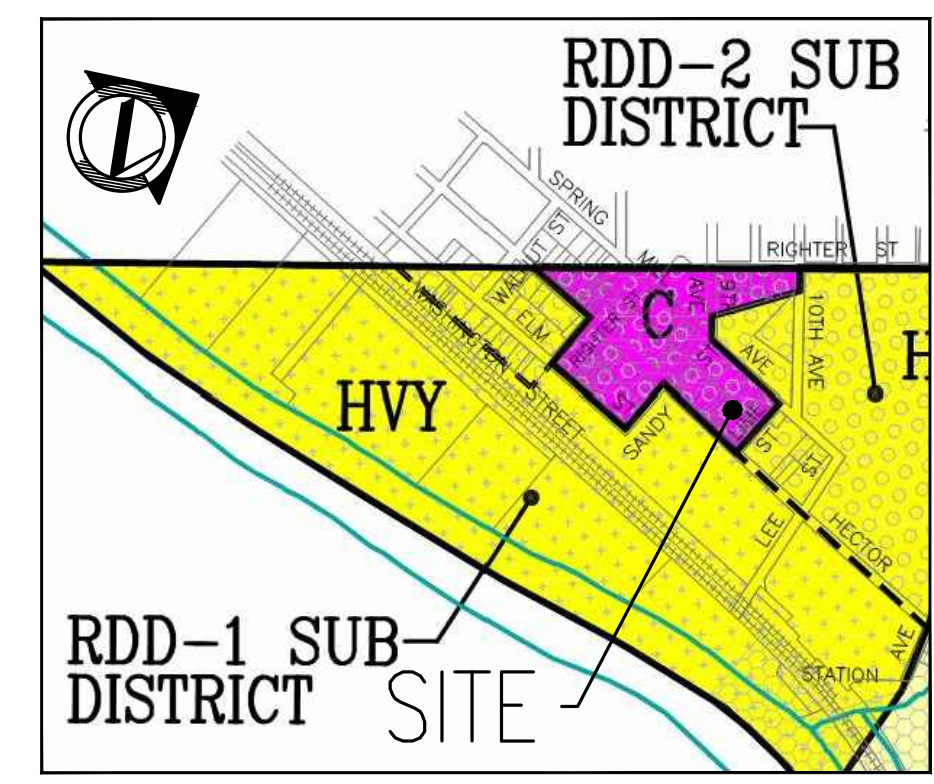
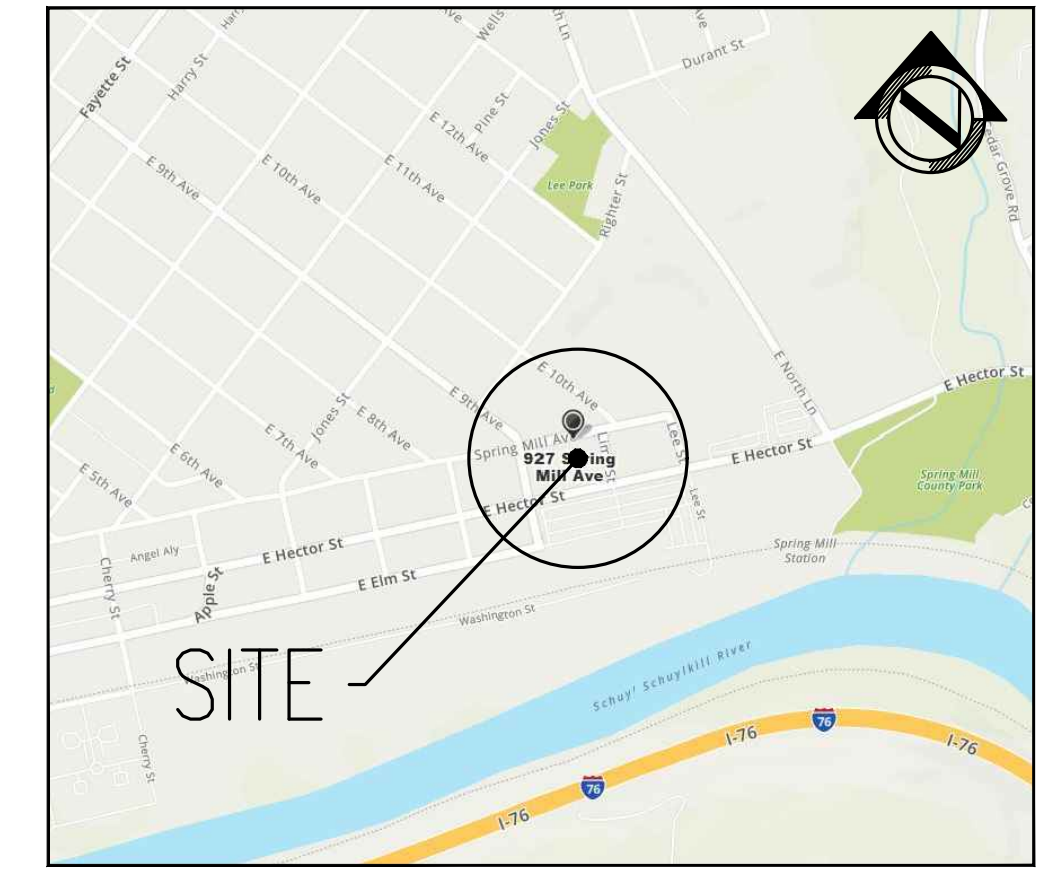

GENERAL NOTES:

- 1. THIS PLAN REFERENCES A SURVEY BY: CORNERSTONE ENGINEERS & ARCHITECTURAL & ARCHITECTURAL, INC. 213 W. MAIN STREET, SUITE 200 LANSDALE, PA 19446. PLAN ENTITLED: "BOUNDARY/LOCATION AND TOPOGRAPHIC SURVEY" PLAN DATED: 03-11-2021
- 2. OWNER/APPLICANT: 931 SPRING MILL AVENUE, LLC C/O BORKOWSKI HOMES 1301 FACETTE STREET CONSHOHOCKEN, PA 19428 610-637-2566
- 3. PROJECT LOCATION INFORMATION: 927 SPRING MILL AVENUE (PARCEL ID #65-00-10759-003), 931 SPRING MILL AVENUE (PARCEL ID #65-00-10753-009), 931 SPRING MILL AVENUE (PARCEL ID #65-00-10751-002), 931 SPRING MILL AVENUE (PARCEL ID #65-00-10750-003) WHITEMARSH TOWNSHIP, MONTGOMERY COUNTY, COMMONWEALTH OF PENNSYLVANIA, 19428
- 4. ZONING INFORMATION: ZONING DISTRICT: C-RESIDENTIAL DISTRICT (NEIGHBORHOOD PRESERVATION) OVERLAY DISTRICT: RIVERFRONT DEVELOPMENT OVERLAY DISTRICT, SUB-DISTRICT 2 (RDD-2) EXISTING USE: VACANT TIRE SHOP PROPOSED USE: MULTI-FAMILY RESIDENTIAL 20 DWELLING UNITS WITH SUB LEVEL PARKING
- 5. ZONING BULK AND AREA REQUIREMENTS: C-RESIDENTIAL ZONING DISTRICT & RDD-2-SUB-DISTRICT: RDD-2-SUB MINIMUM LOT REQUIREMENTS: MIN. LOT AREA: 17,458.34 SF / 0.401 ACRES (GROSS) 10,000 SF EXISTING: 17,458.34 SF / 0.401 ACRES (GROSS) 16,388.79 SF / 0.376 ACRES (NET) PROPOSED: 17,458.34 SF / 0.401 ACRES (GROSS) 16,388.79 SF / 0.376 ACRES (NET) MIN. WIDTH AT BLDG SETBACK: 75 FT 145.5 FT EXISTING: 75 FT 145.5 FT PROPOSED: 145.5 FT MIN. FRONT YARD SETBACK: NONE 0.0 FT EXISTING: 0.0 FT 0.0 FT PROPOSED: 15 FT 0.0 FT EXISTING: 15 FT 0.0 FT PROPOSED: 30 FT 45.8 FT EXISTING: 30 FT 45.8 FT PROPOSED: 35 FT 35 FT EXISTING: 35 FT 35 FT PROPOSED: 60% 25.9% (4,261 SF) EXISTING: 60% 25.9% (4,261 SF) PROPOSED: 92.54% (15,167 SF) EXISTING: 92.54% (15,167 SF) PROPOSED: 60.4% (10,538 SF) EXISTING: 60.4% (10,538 SF)
- 6. PARKING REQUIREMENTS: REQUIRED: RESIDENTIAL USE: 1.75 PARKING SPACES/DWELLING UNIT 1.75 SPACES + 20 DWELLING UNITS = 35 PARKING SPACES REQ'D PROPOSED: 35 PARKING SPACES
- 7. THE WORD "CERTIFY" OR "CERTIFICATE" AS SHOWN AND USED HEREON MEANS AN EXPRESSION OF PROFESSIONAL OPINION REGARDING THE FACTS OF THIS PLAN AND REFERENCED SURVEY AND DOES NOT CONSTITUTE A WARRANTY OR GUARANTEE, EXPRESSED OR IMPLIED.
- 8. THE DRAWING IS PREPARED BY CORNERSTONE CONSULTING ENGINEERS AND ARCHITECTURAL, INC. AND NO PART OF THIS DRAWING MAY BE REPRODUCED BY PHOTOCOPYING, RECORDING OR BY ANY OTHER MEANS, OR STORED, PROCESSED, OR TRANSMITTED IN ANY FORM OR BY ANY MEANS, WITHOUT THE PRIOR WRITTEN PERMISSION OF THE SURVEYOR, ENGINEER, ARCHITECT, OR DESIGN PROFESSIONAL. COPIES OF THIS PLAN WITHOUT A RAISED IMPRESSION OR COLOR SEAL ARE NOT VALID.
- 9. BY GRAPHICAL PLOTTING ONLY THIS PROPERTY IS LOCATED IN FLOOD ZONE X, AREA OF MINIMAL FLOOD HAZARD. MAP ENTITLED "TYPICAL FLOOD INSURANCE RATE MAP, MONTGOMERY COUNTY, PENNSYLVANIA (ALL JURISDICTIONS)", PANEL 358 OF 451 MAP NUMBER 42091C03586, EFFECTIVE 03/02/2016.
- 10. THE APPLICANT IS PROPOSING TO CONSTRUCT A 3-STORY BUILDING CONSISTING OF 20 MULTI-FAMILY APARTMENT UNITS AND ASSOCIATED SITE IMPROVEMENTS.
- 11. THE WATERSHED FOR THE SITE IS THE LOWER SCHUYLKILL RIVER WATERSHED.
- 12. LOCATION OF ALL UNDERGROUND UTILITIES ARE APPROXIMATE. ALL LOCATIONS AND SIZES ARE BASED ON UTILITY MARK-OUTS, ABOVE GROUND STRUCTURES THAT WERE VISIBLE & ACCESSIBLE IN THE FIELD, AND THE MAPS SUPPLIED THROUGH THE PA ONE CALL SYSTEM WHICH WERE AVAILABLE AT THE TIME OF THE SURVEY. BEFORE ANY EXCAVATION IS TO BEGIN, ALL UNDERGROUND UTILITIES SHOULD BE VERIFIED AS TO THEIR LOCATION, SIZE AND TYPE BY THE PROPER UTILITY COMPANIES.
- 13. THE ENTIRE SITE CONTAINS Ugb - URBAN LAND SOIL - 0 TO 8 PERCENT SLOPES (PER THE USDA NATURAL RESOURCES CONSERVATION SERVICE WEB SOIL SURVEY).
- 14. THIS PLAN IS TO BE USED FOR GRAPHICAL REPRESENTATION OF THE PHYSICAL FEATURES OF THE PROPERTY AND NOT TO BE USED FOR CONSTRUCTION. THE BUILDING FOOTPRINT IS CONCEPTUAL ONLY AND ESTABLISHES A BUILDING ENVELOPE IN WHICH THE FINAL BUILDING FOOTPRINT WILL BE GENERALLY LOCATED. THE FINAL BUILDING FOOTPRINT SHALL BE DETERMINED AT THE TIME OF BUILDING PERMIT ISSUANCE AND SHALL BE GENERALLY AS CONFIGURED ON THE PLAN WITH AN OVERALL SQUARE FOOTAGE NOT TO EXCEED THE TOTAL SHOWN ON THE APPROVED PLAN.

LEGEND & ABBREVIATIONS

Legend table with symbols for PROPERTY BOUNDARY, ADJACENT BOUNDARY, RIGHT OF WAY LINE, BUILDING SETBACK LINE, EXISTING TREELINE, EXISTING FENCE, EXISTING OVERHEAD WIRE, EXISTING CURB, EXISTING DEPRESSED CURB (DC), PROP. BLDG., PROP. CONC., PROP. LSA, PROP. PERMEABLE PAVERS, PROP. PAVEMENT RESTORATION, STORM MANHOLE, SANITARY MANHOLE, COMMUNICATION MANHOLE, ELECTRIC MANHOLE, WATER MANHOLE, UNKNOWN MANHOLE, TANK LID, STORM INLET, GAS METER, WATER METER, TRAFFIC SIGNAL BOX, ELECTRIC VAULT, GAS VALVE, WATER VALVE, CLEAN OUT, MONITORING WELL, EXISTING SIGN, EXISTING UTILITY POLE (UP), BENCHMARK.

GRAPHIC SCALE

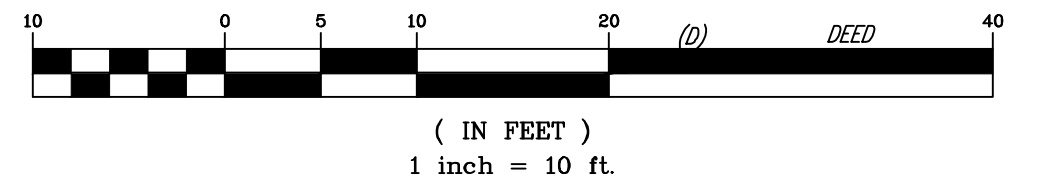

SHEET INDEX

- 1 SITE PLAN
- 2 EXISTING CONDITIONS
- 3 GRADING PLAN
- 4 STORMWATER & UTILITY PLAN
- 5 EROSION & SEDIMENTATION CONTROL PLAN
- 6 EROSION & SEDIMENTATION CONTROL DETAILS
- 7 LIGHTING PLAN
- 8 LANDSCAPE PLAN
- 9 TURNING PLAN
- 10 DETAILS

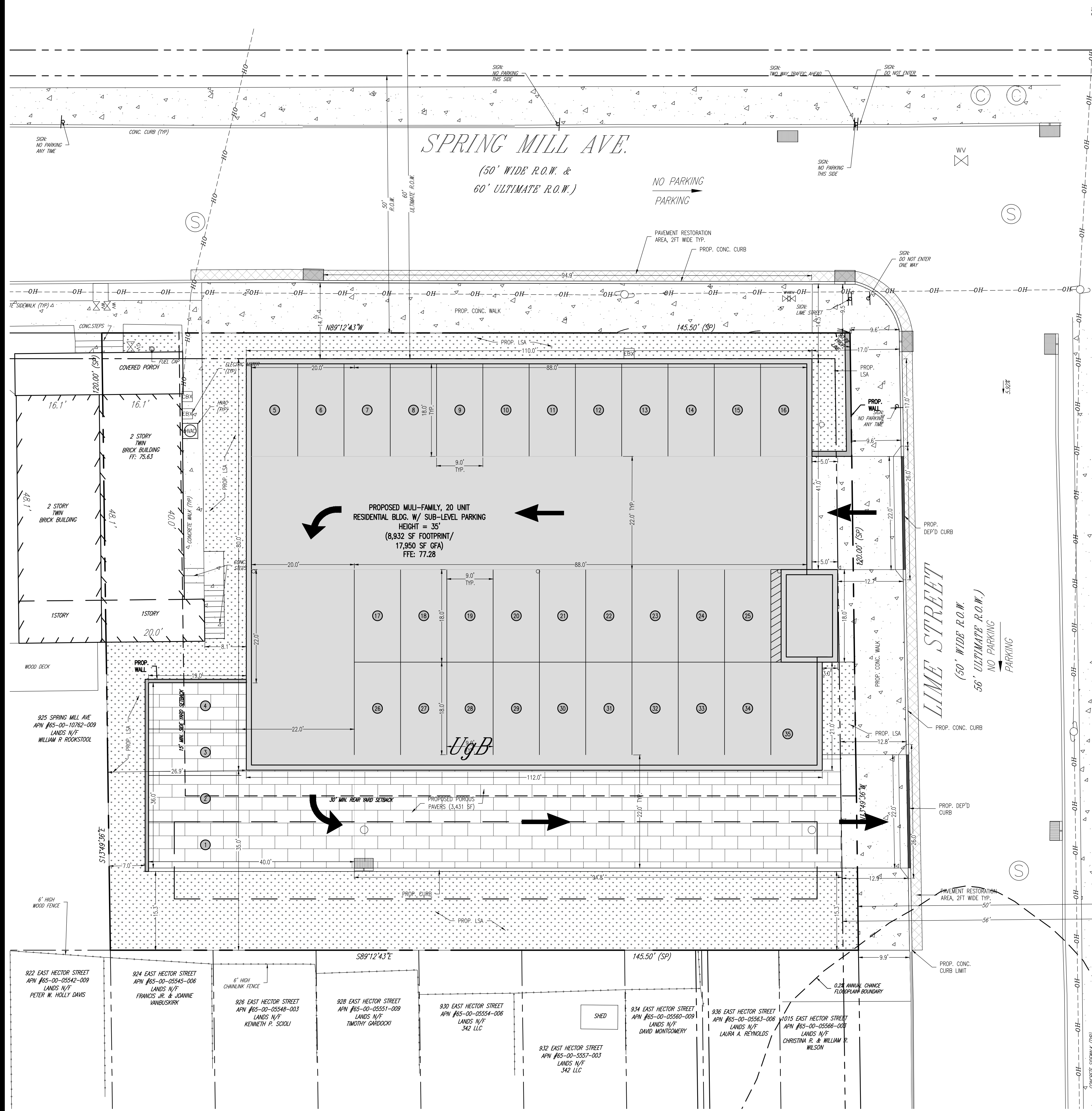

922 EAST HECTOR STREET APN #65-00-05542-009 LANDS N/F PETER W. HOLLY DAVIS

924 EAST HECTOR STREET APN #65-00-05548-006 LANDS N/F FRANCIS JR. & JOANNE VANBUSKIRK

926 EAST HECTOR STREET APN #65-00-05548-003 LANDS N/F KENNETH P. SCOLI

928 EAST HECTOR STREET APN #65-00-05551-009 LANDS N/F TIMOTHY GARDOCKI

930 EAST HECTOR STREET APN #65-00-05554-006 LANDS N/F 342 LLC

932 EAST HECTOR STREET APN #65-00-5557-003 LANDS N/F 342 LLC

934 EAST HECTOR STREET APN #65-00-05560-009 LANDS N/F DAVID MONTGOMERY

936 EAST HECTOR STREET APN #65-00-05563-006 LANDS N/F LAURA A. REYNOLDS

1015 EAST HECTOR STREET APN #65-00-05566-008 LANDS N/F CHRISTINA R. & WILLIAM P. WILSON

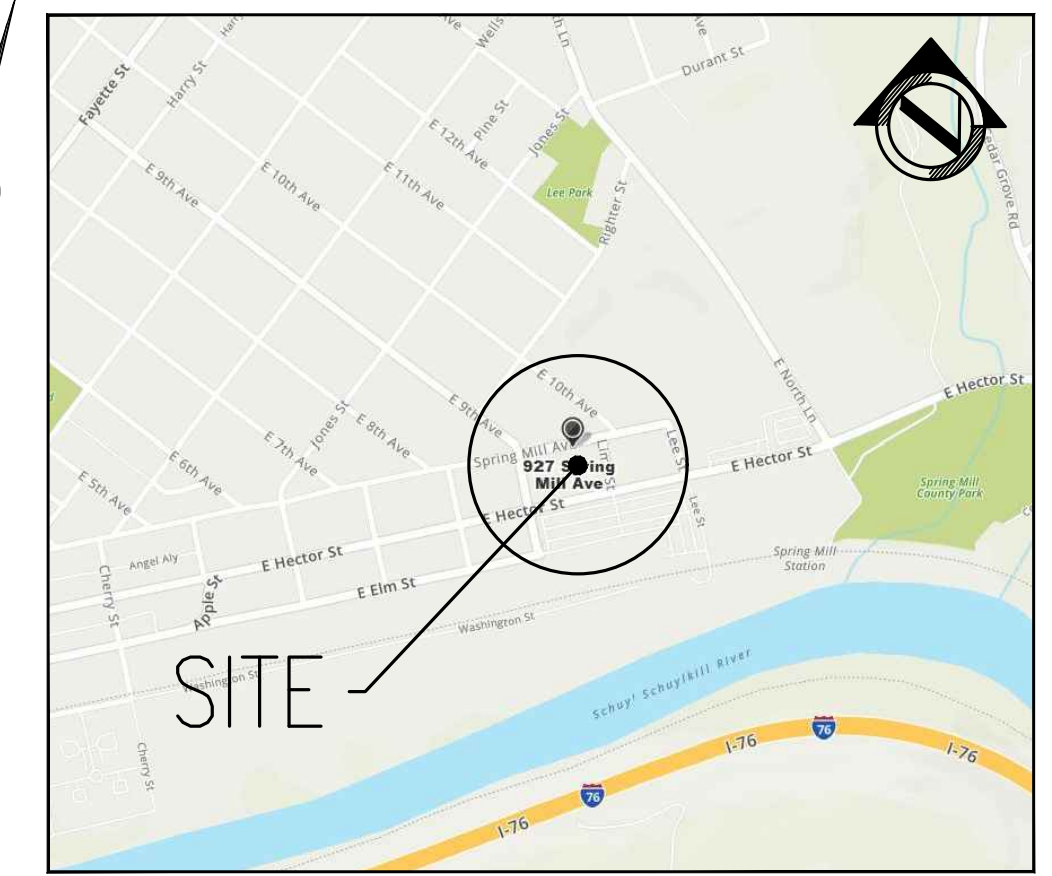

Cornerstone
Consulting Engineers & Architectural, Inc.

213 West Main Street, Lansdale, PA 19446
Phone: 215-362-2600, Fax: 215-362-8400
WWW.CORNERSTONEINC.COM

Pennsylvania Region
570-839-1770

Lehigh Valley Region
610-262-5200

Philadelphia Region
215-562-2600

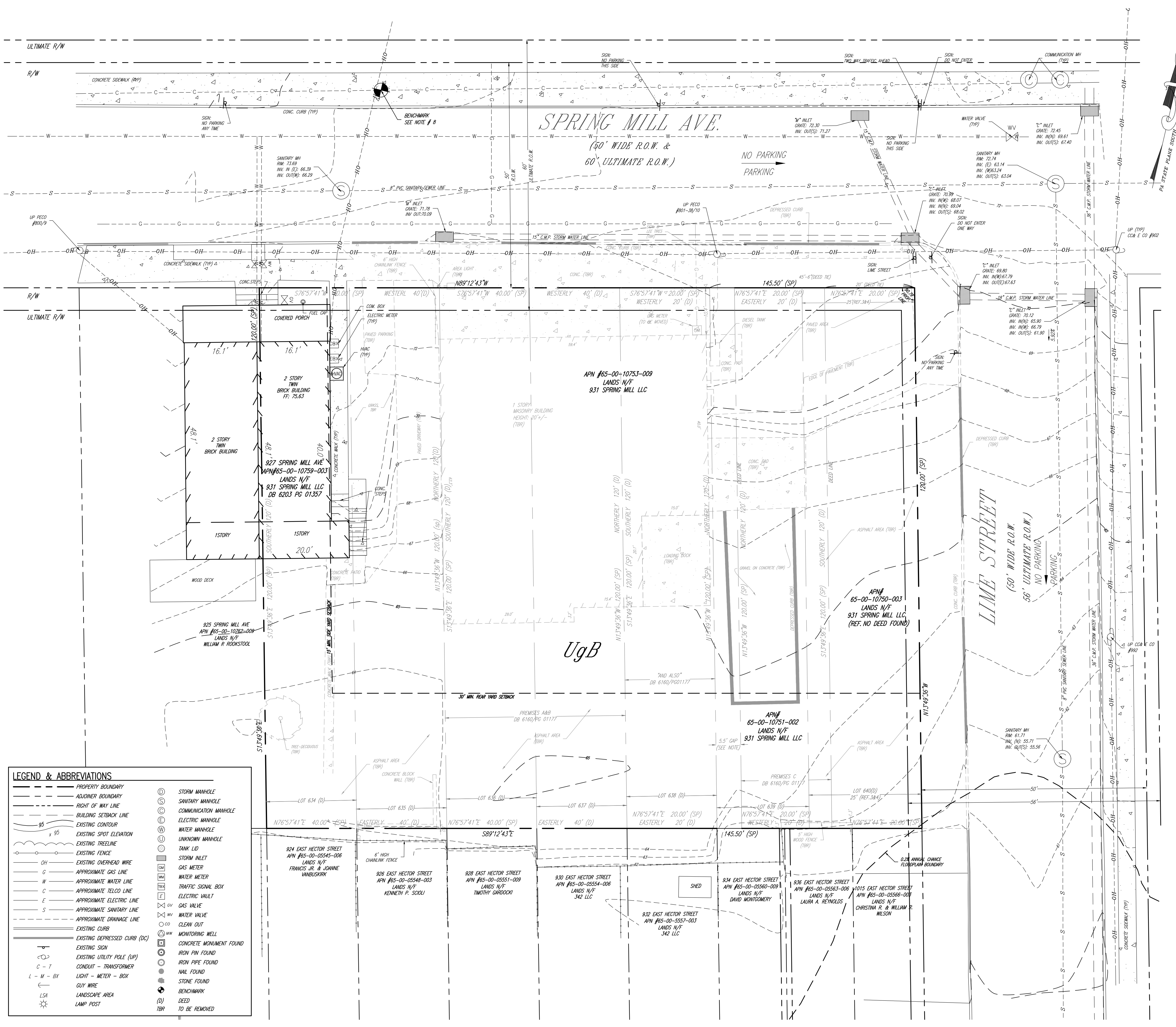

EXISTING CONDITIONS NOTES:

- PROPERTY KNOWN AS: APN #65-00-10759-003, 927 SPRING MILL AVENUE. APN #65-00-10753-009, 931 SPRING MILL AVENUE. APN #65-00-10751-002, 931 SPRING MILL AVENUE. APN #65-00-10750-003, 931 SPRING MILL AVENUE. MONTGOMERY COUNTY, COMMONWEALTH OF PENNSYLVANIA.
- AREA OF PARCEL APN #65-00-10759-003, IS 4,800 SQUARE FEET OR 0.1102 ACRES. AREA OF PARCEL APN #65-00-10753-009, IS 5,400 SQUARE FEET OR 0.1239 ACRES. AREA OF PARCEL APN #65-00-10751-002, IS 2,400 SQUARE FEET OR 0.0551 ACRES. AREA OF PARCEL APN #65-00-10750-003, IS 2,400 SQUARE FEET OR 0.0551 ACRES.
- THE PARCEL FRONTING SPRING MILL AVENUE AND LIME STREET (AS PER REF. 3) CITES THE LEGAL DESCRIPTION AS LOT 640 BEING 25 FEET ALONG SPRING MILL AND 120 FEET ALONG LIME, AND ALSO CITES THE PARCEL AS BEING #65-00-10750-003 BUT DOES NOT HAVE A RECORD DEED FOR THE PARCEL AVAILABLE. THE PLACEMENT OF THIS PARCEL PER REFERENCE 3 CREATES A 5.5 FOOT OVERLAP WITH PARCEL #65-00-10751-002 TO THE WEST.
- IT IS BELIEVED THAT THE INTENT OF THE DESCRIPTION FOR PARCEL INTERSECTION OF THE SOUTHERLY LINE OF SPRING MILL AVENUE WITH LIME STREET IS TO BE 25 FEET FROM THE INTERSECTION OF THE SOUTHERLY LINE OF SPRING MILL AVENUE WITH LIME STREET, THIS CREATING ONLY A 0.5 FOOT GAP (GORE) BETWEEN PARCEL #65-00-10751-002 AND THE AFORESAID PARCEL #65-00-10753-009.
- REPRESENTATION OF ALL UNDERGROUND UTILITIES ARE APPROXIMATE AND ARE NOT AS-BUILT LOCATIONS. ABOVE GROUND STRUCTURES THAT WERE VISIBLE & ACCESSIBLE IN THE FIELD ARE SHOWN. ALL LOCATIONS AND SIZES ARE BASED ON UTILITY MARK-OUTS, AND THE MARKS LISTED IN THE REFERENCES AVAILABLE AT THE TIME OF THE SURVEY. BEFORE ANY EXCAVATION IS TO BEGIN, ALL UNDERGROUND UTILITIES SHOULD BE VERIFIED AS TO THEIR LOCATION, SIZE AND TYPE BY THE PROPER UTILITY COMPANIES.
- THIS PLAN IS BASED ON INFORMATION PROVIDED BY A SURVEY PREPARED IN THE FIELD BY CORNERSTONE CONSULTING ENGINEERS AND ARCHITECTURAL, INC., AND OTHER REFERENCE MATERIAL AS LISTED HEREON. SURVEY & TOPOGRAPHIC INFORMATION SHOWN HEREON DERIVED FROM A FIELD SURVEY PERFORMED BY CORNERSTONE CONSULTING LATEST DATE MARCH 04, 2021.
- COPYRIGHT © 2021, CORNERSTONE CONSULTING ENGINEERS AND ARCHITECTURAL, INC. ALL RIGHTS RESERVED. NO PART OF THIS DRAWING MAY BE REPRODUCED BY PHOTOCOPYING, RECORDING OR BY ANY OTHER MEANS, OR STORED, PROCESSED, OR TRANSMITTED IN OR BY ANY COMPUTER OR OTHER SYSTEMS WITHOUT THE PRIOR WRITTEN PERMISSION OF THE SURVEYOR. COPIES OF THIS PLAN WITHOUT A RAISED OR COLORED SEAL ARE NOT VALID.
- THIS PLAN IS VALID ONLY WHEN SIGNED AND SEALED WITH A RAISED OR COLORED SEAL AND WAS PREPARED IN ACCORDANCE WITH THE MINIMUM STANDARD OF ACCURACY OF THE STATE IN WHICH THE PROJECT IS LOCATED. THE WORD "CERTIFY" OR "CERTIFICATE" AS SHOWN AND USED HEREON MEANS AN EXPRESSION OF PROFESSIONAL OPINION REGARDING THE FACTS OF THIS PLAN AND REFERENCED SURVEY AND DOES NOT CONSTITUTE A WARRANTY OR GUARANTEE, EXPRESSED OR IMPLIED.
- DATUM BASED UPON PENNSYLVANIA STATE PLANE SOUTH ZONE 3702 USING HORIZONTAL VALUES FROM NAD83 AND VERTICAL VALUES FROM NAVD83.
- SITE BENCHMARK IS MAG. NAIL SET. ELEVATION = 74.44' TO ENSURE THAT THERE HAS BEEN NO ALTERATION OF THE SURVEY BENCHMARK SINCE THE TIME OF THE FIELD SURVEY. IT IS RECOMMENDED THAT THE CONTRACTOR ESTABLISH A CONSTRUCTION BENCHMARK BASED ON THE SURVEY BENCHMARK AND ELEVATIONS OF OTHER EXISTING IMPROVEMENTS.
- THIS SURVEY WAS PREPARED WITHOUT THE BENEFIT OF A TITLE REPORT AND SUBJECT THERETO.
- SUBJECT TO ANY AND ALL EASEMENTS OF RECORD WHETHER SHOWN HEREON OR NOT.
- BY GRAPHICAL PLOTTING ONLY THIS PROPERTY IS LOCATED IN FEMA FLOOD MAP - ZONE X. (SEE MAP REFERENCE #2).
- BOUNDARY RESOLUTION BASED ON FOUND EVIDENCE AND OTHER REFERENCE MATERIALS AS LISTED HEREON AVAILABLE AT THE TIME OF SURVEY.

REFERENCES:

- TAX MAPS OF MONTGOMERY COUNTY, COMMONWEALTH OF PENNSYLVANIA.
- MAP ENTITLED "FIRM, FLOOD INSURANCE RATE MAP, MONTGOMERY COUNTY, PENNSYLVANIA (ALL JURISDICTIONS)," PANEL 358 OF 451 MAP NUMBER 42091C03586, EFFECTIVE 03/02/2016.
- PROPERTY DETAIL REPORTS FROM DATA TREE BY FIRST AMERICAN FINANCIAL CORPORATION AND/OR ITS AFFILIATES.
- MAP PARTIALLY ENTITLED "WHITMARSH TOWNSHIP BLOCK NO. 10," MAP PROVIDED BY TOWNSHIP ENGINEER.

LEGEND & ABBREVIATIONS

	PROPERTY BOUNDARY		STORM MANHOLE
	ADJOINER BOUNDARY		SANITARY MANHOLE
	RIGHT OF WAY LINE		COMMUNICATION MANHOLE
	BUILDING SETBACK LINE		ELECTRIC MANHOLE
	EXISTING CONTOUR		WATER MANHOLE
	EXISTING SPOT ELEVATION		UNKNOWN MANHOLE
	EXISTING TREELINE		TANK LID
	EXISTING FENCE		STORM INLET
	EXISTING OVERHEAD WIRE		GAS METER
	APPROXIMATE GAS LINE		WATER METER
	APPROXIMATE WATER LINE		TRAFFIC SIGNAL BOX
	APPROXIMATE TELCO LINE		ELECTRIC VAULT
	APPROXIMATE ELECTRIC LINE		GAS VALVE
	APPROXIMATE SANITARY LINE		WATER VALVE
	APPROXIMATE DRAINAGE LINE		CLEAN OUT
	EXISTING CURB		MONITORING WELL
	EXISTING DEPRESSED CURB (DC)		CONCRETE MONUMENT FOUND
	EXISTING SIGN		IRON PIN FOUND
	EXISTING UTILITY POLE (UP)		IRON PIPE FOUND
	CONDUIT - TRANSFORMER		NAIL FOUND
	LIGHT - METER - BOX		STONE FOUND
	GUY WIRE		BENCHMARK
	LANDSCAPE AREA		DEED
	LAMP POST		TO BE REMOVED

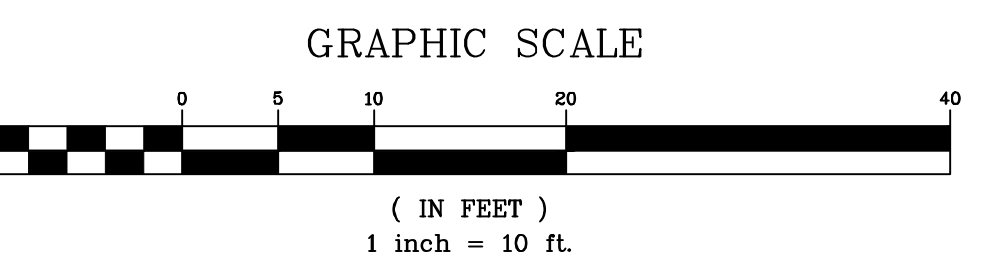

NO	BY	DESCRIPTION	DATE

PENNSYLVANIA
ONE CALL SYSTEM, INC.
923 Inva Road
West Mifflin, Pennsylvania
15122-1078

BEFORE YOU DIG ANYWHERE IN PENNSYLVANIA! CALL 1-800-242-1776 SN: 2021041243

NON-MEMBERS MUST BE CONTACTED DIRECTLY PA LAW REQUIRES THREE WORKING DAYS NOTICE TO UTILITIES BEFORE YOU EXCAVATE. DRILL, BLAST OR BOMBUSH!

J.B. ANDERSON
PROFESSIONAL ENGINEER
P.E. ARE LICENSE NO. PE 15458
PENNSYLVANIA LICENSE NO. PE 055536
MARYLAND LICENSE NO. 2013
NEW JERSEY LICENSE NO. 2468425040
VIRGINIA LICENSE NO. 68018425

PROJECT LOCATION

BORKOWSKI HOMES
PRESENTS
WESTY PROJECT

931 SPRING MILL AVENUE, LLC
927-31 SPRING MILL AVENUE
WHITMARSH TOWNSHIP
MONTGOMERY COUNTY
COMMONWEALTH OF PENNSYLVANIA

TITLE			
EXISTING CONDITIONS PLAN			
PROJ. #	21-0231	DATE	12-30-2021
CAD ID.	21-0231	DRN BY	EMR
SCALE	AS NOTED	CHK BY	JBA
SHEET 2 OF 10			
REVISION #			

POST CONSTRUCTION STORMWATER MANAGEMENT BMP'S PROPOSED FOR THIS PROJECT:

INFILTRATION BED DESIGN CALCULATION

GROUNDWATER RECHARGE VOLUME REQUIRED:
- Rev = [(S)(P)(A))/12
- Rev = [(0.13)(0.05 + 0.009(0.35/0.44) x 100)(0.44)]/12 = 0.00365 AC-FT x 43560 = 158.99 CF
- VOLUME REQUIRED = 158.99 CF
- A 15' x 125' x 3.77' STONE BED = 7068.75 x 0.40 = 2827.5 CF PROPOSED

POST CONSTRUCTION STORMWATER MANAGEMENT NOTES:

- 1. LIMIT OF DISTURBANCE IS 0.44 ACRES.
2. SITE IS LOCATED IN SCHUPLIKILL RIVER WATERSHED.
3. PROJECT IS LOCATED AT 927-931 SPRING MILL AVE. ON THE SOUTHERN SIDE OF SPRING MILL AVE.
4. THESE PCSM PLANS SHALL BE RECORDED PRIOR TO CONSTRUCTION.
5. THIS PROJECT PROPOSES BMP'S THAT ARE CRITICAL TO THE POST CONSTRUCTION STORM WATER MANAGEMENT OF THE SITE AND THE INSTALLATION OF THESE BMP'S REQUIRES REVIEW BY A DESIGN PROFESSIONAL DURING CONSTRUCTION. IT SHALL BE THE RESPONSIBILITY OF THE CONTRACTOR TO ENSURE THAT ALL REVIEWS ARE SCHEDULED IN ADVANCE AND INCORPORATED INTO THE CONSTRUCTION SCHEDULE. PLEASE REFER TO THE SEQUENCE OF CONSTRUCTION FOR INSTALLATION REVIEW OF CRITICAL BMP'S.
6. NO RIPARIAN BUFFERS ARE PROPOSED. THE PROJECT IS NOT LOCATED WITHIN A SPECIAL VALUE WATERSHED.
7. THE PLAN HAS BEEN DESIGNED TO MINIMIZE IMPERVIOUS AREAS.
8. THE PLAN MAXIMIZES THE PROTECTION OF EXISTING DRAINAGE FEATURES AND VEGETATION.
9. THE PLAN HAS BEEN DESIGNED TO MINIMIZE LAND CLEARING AND GRADING.
10. THE PLAN MINIMIZES SOIL COMPACTION.
11. THE PERMIT HOLDER SHALL ARRANGE TO HAVE ALL CONSTRUCTION REVIEWS, AS-BUILT PLANS, AND FORMS COMPLETED BY THE PARTY CONDUCTING THE CRITICAL BMP INSTALLATION REVIEWS.
12. CONFIRMATION TESTING SHALL BE COMPLETED AT THE INFILTRATION BASIN BOTTOM DEPTHS DURING CONSTRUCTION FOR INSTALLATION REVIEW OF CRITICAL BMP'S.
13. THE LONG TERM OPERATION AND MAINTENANCE OF THESE BMP'S IS THE RESPONSIBILITY OF THE PROPERTY OWNER. THE PROPERTY OWNER SHALL KEEP A LOG OF BMP INSPECTIONS AS OUTLINED IN THE MAINTENANCE SCHEDULE.
14. ANY CHANGES AFTER THE NOTICE OF TERMINATION IS COMPLETED ARE SUBJECT TO APPROVAL BY UPPER DUBLIN TOWNSHIP, THE MONTGOMERY COUNTY CONSERVATION DISTRICT, AND THE PENNSYLVANIA DEPARTMENT OF ENVIRONMENTAL PROTECTION.
15. RESPONSIBLE AGENT:
BORKOWSKI HOMES
1301 FAYETTE ST
CONSHOHOCKEN, PA 19428
ATTN: CHUCK BORKOWSKI, PH (610) 637-2566

GENERAL STORMWATER MAINTENANCE NOTES

- MATERIALS REMOVED FROM BMP'S DURING MAINTENANCE AND REPAIR ACTIVITIES SHALL BE DISPOSED OF IN ACCORDANCE WITH LOCAL, STATE AND FEDERAL REGULATIONS AT EITHER A PROPERLY LICENSED LANDFILL OR A COMPOSTING FACILITY. MORE SPECIFICALLY:
- IF MOWING ACTIVITIES OCCUR WITHIN ABOVE GRADE BMP'S, THE OPERATOR IS REQUIRED TO COLLECT ALL GRASS CLIPPINGS AND DISPOSE OF THE CLIPPINGS IN A LANDFILL OR COMPOSTING FACILITY.
- ANY SEDIMENT TAKEN FROM BMP'S SHALL BE DISPOSED OF IN A LANDFILL.
- TRASH SHALL BE PROPERLY DISPOSED OF BY A TRASH CARRIER OR BROUGHT DIRECTLY TO A LANDFILL. APPROPRIATE MATERIALS SHALL BE RECYCLED BY A RECYCLING CARRIER OR BROUGHT TO A RECYCLING CENTER.
- ANY WEEDS OR DETRITUS TAKEN FROM ABOVE GRADE BMP'S SHALL BE DISPOSED OF IN A LANDFILL OR BROUGHT TO A COMPOSTING CENTER.
MATERIALS REMOVED FROM BMP'S DURING MAINTENANCE AND REPAIR ACTIVITIES SHALL BE DISPOSED OF IN ACCORDANCE WITH LOCAL, STATE AND FEDERAL REGULATIONS AT EITHER A PROPERLY LICENSED LANDFILL OR A COMPOSTING FACILITY. MORE SPECIFICALLY:
- IF MOWING ACTIVITIES OCCUR WITHIN ABOVE GRADE BMP'S, THE OPERATOR IS REQUIRED TO COLLECT ALL GRASS CLIPPINGS AND DISPOSE OF THE CLIPPINGS IN A LANDFILL OR COMPOSTING FACILITY.
- ANY SEDIMENT TAKEN FROM BMP'S SHALL BE DISPOSED OF IN A LANDFILL.
- TRASH SHALL BE PROPERLY DISPOSED OF BY A TRASH CARRIER OR BROUGHT DIRECTLY TO A LANDFILL. APPROPRIATE MATERIALS SHALL BE RECYCLED BY A RECYCLING CARRIER OR BROUGHT TO A RECYCLING CENTER.
- ANY WEEDS OR DETRITUS TAKEN FROM ABOVE GRADE BMP'S SHALL BE DISPOSED OF IN A LANDFILL OR BROUGHT TO A COMPOSTING CENTER.

BMP MATERIAL DISPOSAL REQUIREMENTS

- CONSTRUCTION WASTE AND PROPER WASTE DISPOSAL NOTES
1. THE DEVELOPMENT OF THE SITE WILL CREATE DEBRIS MATERIAL TO BE REMOVED FROM THE PROPERTY. IT WILL CONSIST OF THE EXISTING ASPHALT, CONCRETE, BRICKS, AND OTHER BUILDING MATERIAL FROM THE EXISTING STRUCTURES TO BE DEMOLISHED. THE ASPHALT, BRICK, AND CONCRETE WILL BE TAKEN TO A RECYCLE CENTER AND THE OTHER DEBRIS WILL BE TAKEN TO THE APPROPRIATE LANDFILL SITE. ALL WASTE PRODUCTS FROM THE CONSTRUCTION OF THE SITE IMPROVEMENTS AND BUILDING WILL BE DISPOSED OF OR RECYCLED IN ACCORDANCE WITH THE ABOVE REGULATIONS AND LOCAL MUNICIPAL REGULATIONS.

WATER GENERAL NOTES

- 1. ALL WATER FACILITIES SHALL BE CONSTRUCTED IN ACCORDANCE WITH LOCAL AUTHORITY FACILITIES LINE EXTENSION AGREEMENT SPECIFICATIONS.
2. LOCATION OF EXISTING WATER FACILITIES SHOWN ARE APPROXIMATE. ANY UTILITIES NOT SHOWN, OR NOT LOCATED AS SHOWN, SHALL NOT BE THE CAUSE OF THE CONTRACTOR TO DENY RESPONSIBILITY FOR PROTECTION AND/OR REPAIR DURING CONSTRUCTION. EXACT LOCATION SHALL BE VERIFIED IN THE FIELD.
3. ALL WATER MAINS REQUIRE A MINIMUM OF FOUR (4) FEET COVER UNLESS OTHERWISE APPROVED BY AQUA.
4. WATER AND SANITARY SEWER LINES SHALL HAVE A MINIMUM OF TEN (10) FEET HORIZONTAL SEPARATION.
5. WATER AND STORM SEWER LINES SHALL HAVE A MINIMUM OF FOUR (4) FEET HORIZONTAL SEPARATION.
6. SANITARY AND STORM SEWER LINES SHALL HAVE A MINIMUM OF EIGHTEEN (18) INCH VERTICAL SEPARATION FROM THE WATER LINE UNLESS OTHERWISE APPROVED.
7. HYDRANT LOCATION IS SUBJECT TO THE APPROVAL OF THE FIRE OFFICIALS CLAIMING JURISDICTION OVER THE PROJECT LOCATION.
8. ONLY AUTHORITY SHALL OPERATE MAIN LINE VALVES FOR THE CONTRACTOR.
9. EASEMENTS SHALL BE REQUIRED FOR ALL WATER FACILITIES LOCATED OUTSIDE THE PUBLIC RIGHT OF WAY.
10. ALL FIRE HYDRANTS SHALL INCLUDE A 6" GATE VALVE ON THE HYDRANT LATERAL.
11. THE USE OF FITTINGS SHALL BE MINIMIZED. INSTEAD, CONTRACTOR SHALL DEFLECT PIPE SEGMENTS AS NECESSARY.
12. METER BOXES SHALL BE INSTALLED IN AN AREA BEHIND THE CURB (IF APPLICABLE) FOR DWELLINGS THAT ARE GREATER THAN 100 FEET FROM THE CURB. METER BOX LOCATIONS ARE SUBJECT TO FINAL APPROVAL BY AUTHORITY. METER BOXES MUST MEET THE REQUIRED SPECIFICATIONS.
13. DEVELOPER SHALL OBTAIN ALL NECESSARY ROAD OPENING PERMITS REQUIRED FOR THE INSTALLATION OF THE WATER FACILITIES, AND SHALL BE RESPONSIBLE FOR THE PAYMENT OF ALL APPLICATION FEES AND INSPECTION COSTS ASSOCIATED WITH THESE PERMITS.

SANITARY SEWER NOTES

- 1. SANITARY SEWER MAINS SHALL BE SDR 26 PVC, ASTM 3034; ALL BUILDING LATERALS SHALL BE 4 INCH SDR 26 PVC. IN ADDITION A METALLIC UTILITY WARNING TAPE SHALL BE INSTALLED 24" TO 30" BELOW THE SURFACE OF THE GROUND.
2. ALL SANITARY SYSTEM MATERIALS AND CONSTRUCTION SHALL BE IN ACCORDANCE WITH THE SEWER AUTHORITY STANDARDS AND SPECIFICATIONS, LATEST REVISION.
3. ALL PROPOSED SANITARY SEWER SERVICES SHALL BE COORDINATED WITH THE MECHANICAL/PLUMBING CONSTRUCTION DOCUMENTS.
4. SANITARY SEWER LINES AND STORM SEWER CROSSINGS SHALL HAVE A MINIMUM VERTICAL CLEARANCE OF EIGHTEEN (18) INCHES OR A MINIMUM HORIZONTAL SEPARATION OF TEN (10) FEET. IF 18" VERTICAL CLEARANCE CANNOT BE MAINTAINED, THE SANITARY SEWER OR SEWER LATERAL SHALL BE CONCRETE ENCASED, IN ACCORDANCE WITH PA D.E.P. REQUIREMENTS.
5. THE SANITARY SEWERS, PIPELINES, AND EASEMENTS ARE TO BE OFFERED TO THE SEWER AUTHORITY FOR DEDICATION.
6. ALL SEWER LATERAL CONNECTIONS TO THE GRAVITY MAIN SHALL BE MADE USING A "WYE" CONNECTION.
7. ALL SANITARY MANHOLES SHALL BE 4 FT. DIAMETER, UNLESS NOTED OTHERWISE.

LEGEND & ABBREVIATIONS

Table with 2 columns: Symbol and Description. Includes symbols for Property Boundary, Adjoining Boundary, Right of Way Line, Building Setback Line, Existing Contour, Existing Spot Elevation, Existing Treeline, Existing Fence, Existing Overhead Wire, Existing Curbs, Existing Depressed Curbs (DC), Existing Signs, Existing Utility Pole (UP), Landscape Area, Lamp Post, Benchmark, Deed, Storm Manhole, Sanitary Manhole, Communication Manhole, Electric Manhole, Water Manhole, Unknown Manhole, Tank Lid, Storm Inlet, Gas Meter, Water Meter, Traffic Signal Box, Electric Vault, Gas Valve, Gas Valve, Water Valve, Clean Out, Monitoring Well.

UTILITY NOTES

GENERAL NOTES

- 1. COORDINATE LOCATIONS AND TIE-IN POINTS OF PROPOSED MECHANICAL AND ELECTRICAL SYSTEMS WITH THE APPROPRIATE CONSULTANTS PLANS, AND / OR THE APPROPRIATE GOVERNMENTAL AGENCY HAVING JURISDICTION AT THE TIME OF CONSTRUCTION.
2. ALL TRENCHES SHALL BE SHORED IN ACCORDANCE WITH OSHA STANDARDS.
3. ALL ELECTRICAL LINES TO LIGHT POLES SHALL BE INSTALLED IN 1 1/2" PVC CONDUIT WITH NECESSARY PULL/JUNCTION BOXES.
4. CLEANOUTS AND CURB BOXES WITHIN PAVED AREAS MUST HAVE TRAFFIC LOADING FRAMES AND COVERS MEETING HS-20 LIVE LOAD.
5. CONTRACTOR SHALL NOT CONNECT PIPES INTO THE CORNER OF INLET BOXES.
6. ALL MATERIALS AND METHODS OF CONSTRUCTION ARE TO BE IN ACCORDANCE WITH WHITPAIN TOWNSHIP. INTERPRETATION SHALL REST WITH THE TOWNSHIP ENGINEER OR THE TOWNSHIP ENGINEER'S REPRESENTATIVE IN THE FIELD.
7. THE TOWNSHIP IS GRANTED A BLANKET EASEMENT AND RIGHT OF ACCESS TO ENTER UPON ANY PORTION OF THE PROPERTY FROM TIME TO TIME TO INSPECT ALL STORMWATER BMP'S, TO CONFIRM THAT THE PROPERTY IS IN COMPLIANCE WITH ITS OBLIGATIONS TO MAINTAIN, REPAIR, AND REPLACE THE SAME IN ACCORDANCE WITH THE O&M PLAN AND THE BMP AGREEMENT, AND TO ENFORCE THE TERMS THEREOF.

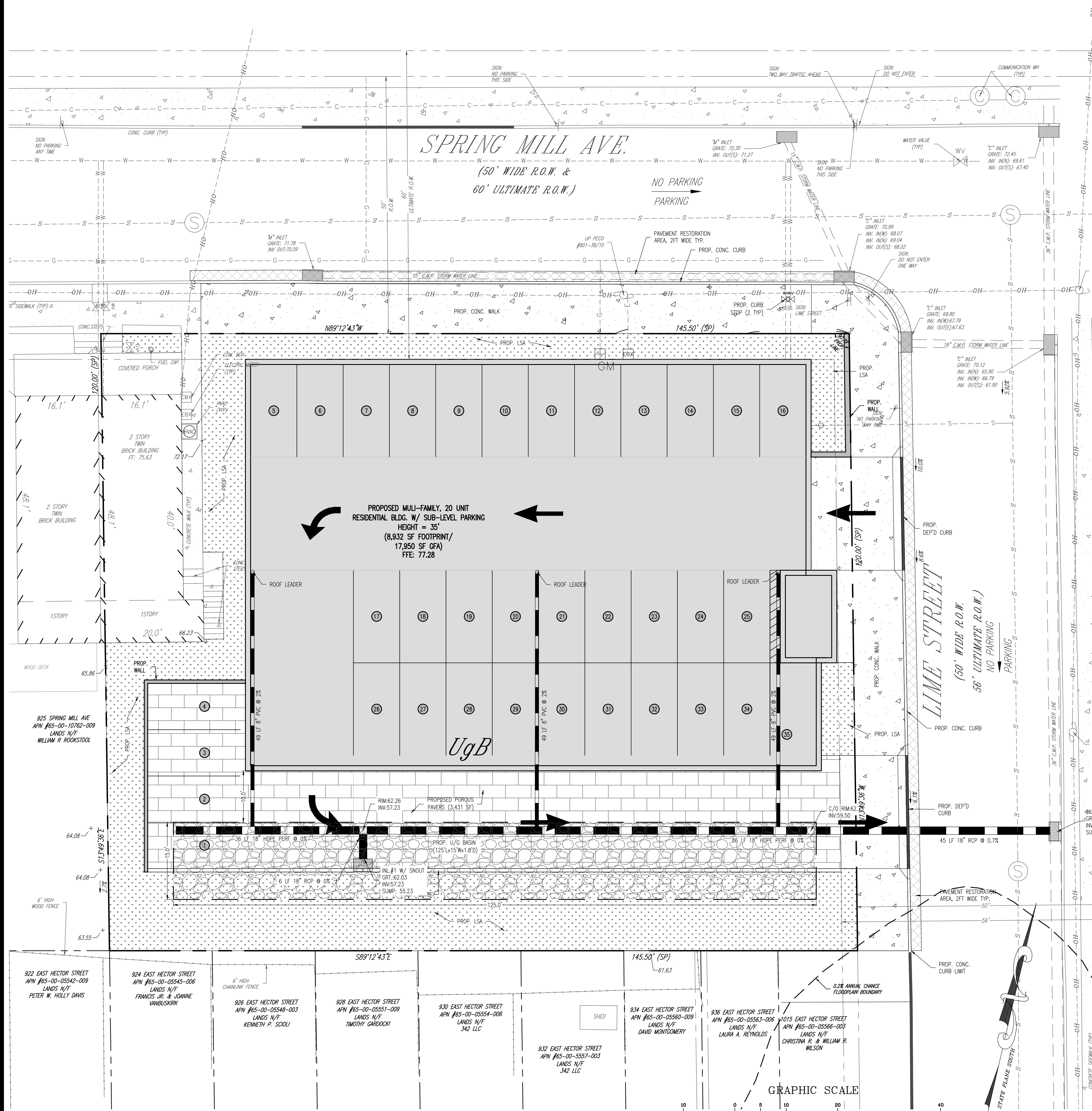

Cornerstone Consulting Engineers & Architectural, Inc.
213 West Main Street, Lumberville, PA 19446
Phone: 215-362-2600, Fax: 215-362-8400
www.cornerstoneinc.com
Philadelphia Region: 215-362-2600
Pocono Region: 570-839-1770

Table with 3 columns: NO, BY, DESCRIPTION. Includes a section for REVISIONS.

PENNSYLVANIA ONE CALL SYSTEM, INC.
925 Penn Park Road
West Mifflin, Pennsylvania 15122-1078
BEFORE YOU DIG ANYWHERE IN PENNSYLVANIA! CALL 1-800-242-1776
SN: 20210471243
NON-MEMBERS MUST BE CONTACTED DIRECTLY
PALAW REQUIRES THREE WORKING DAYS NOTICE TO UTILITIES BEFORE YOU EXCAVATE, DRILL, OR DEMOLISH.

J.B. ANDERSON
PROFESSIONAL ENGINEER
DELAWARE LICENSE NO. PE 15438
PENNSYLVANIA LICENSE NO. PE 055536
NEW JERSEY LICENSE NO. 24693
VIRGINIA LICENSE NO. 6403-045725

BORKOWSKI HOMES PRESENTS WESTY PROJECT
931 SPRING MILL AVENUE, LLC
927-31 SPRING MILL AVENUE
WHITEMARSH TOWNSHIP
MONTGOMERY COUNTY
COMMONWEALTH OF PENNSYLVANIA
TITLE: STORMWATER & UTILITY PLAN
PROJ.#: 21-4231 DATE: 12-30-2021
CAD ID: 21-4231 DRN BY: EBR
SCALE: AS NOTED CHK BY: JBA
SHEET 4 OF 10
REVISION 0

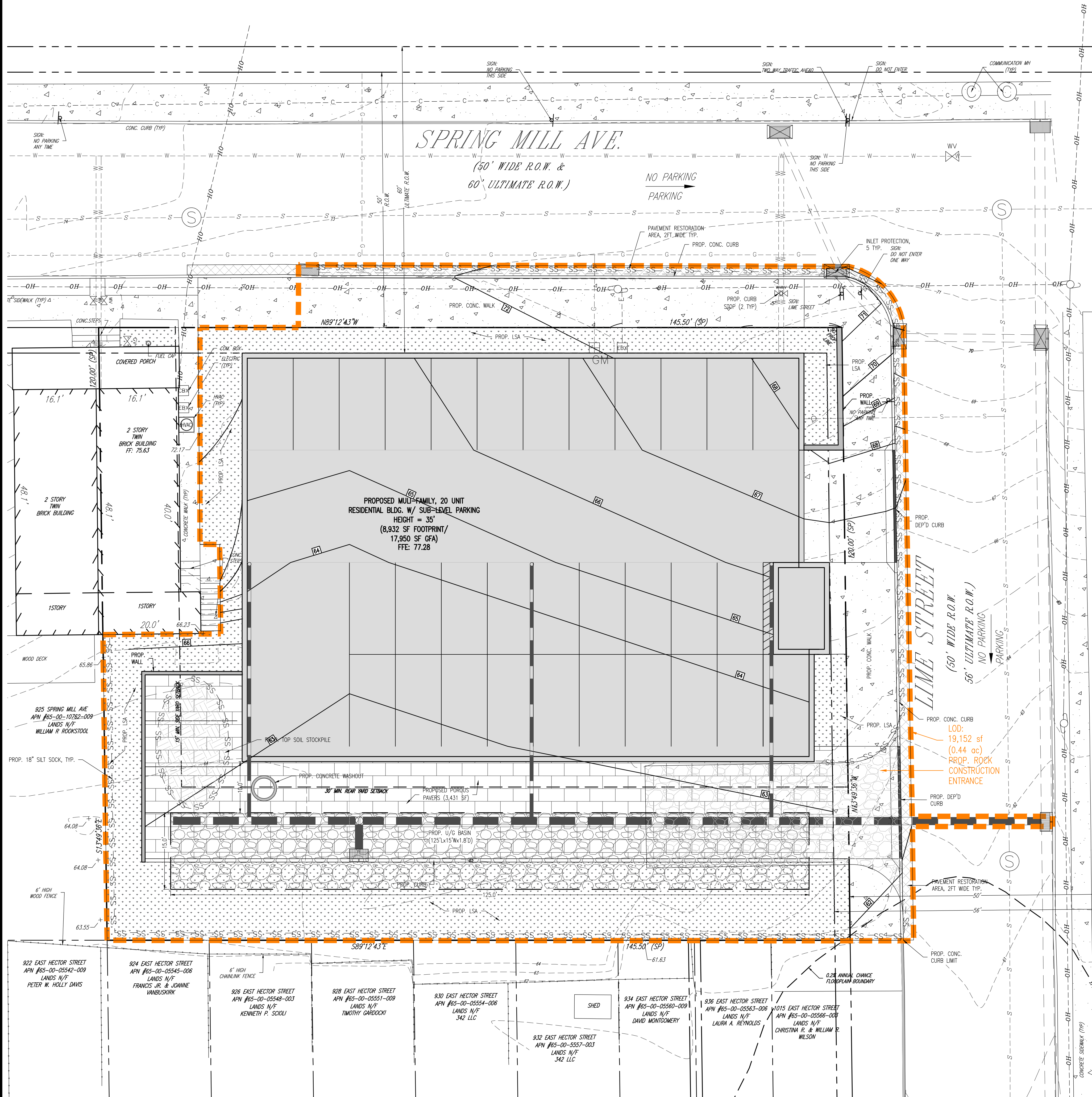

STANDARD E&S PLAN NOTES (APPENDIX C E&S MANUAL)

- All earth disturbances, including clearing and grubbing as well as cuts and fills shall be done in accordance with the approved E&S plan. A copy of the approved drawings (stamped, signed and dated by the reviewing agency) must be available at the project site at all times. The reviewing agency shall be notified of any changes to the approved plan prior to implementation of those changes. The reviewing agency may require a written submittal of those changes for review and approval at its discretion.
- At least 7 days prior to starting any earth disturbance activities, including clearing and grubbing, the owner and/or operator shall invite all contractors, the landowner, appropriate municipal officials, the E&S plan preparer, the PCSM plan preparer, and the licensed professional responsible for oversight of critical stages of implementation of the PCSM plan, and a representative from the local conservation district to an on-site preconstruction meeting.
- At least 3 days prior to starting any earth disturbance activities, or expanding into an area previously unmarked, the Pennsylvania One Call System Inc. shall be notified at 1-800-242-1776 for the location of existing underground utilities.
- All earth disturbance activities shall proceed in accordance with the sequence provided on the plan drawings. Deviation from that sequence must be approved in writing from the local conservation district or by the Department prior to implementation.
- Areas to be filled are to be cleared, grubbed, and stripped of topsoil to remove trees, vegetation, roots and other objectionable material.
- Clearing, grubbing, and topsoil stripping shall be limited to those areas described in each stage of the construction sequence. General site clearing, grubbing and topsoil stripping may not commence in any stage or phase of the project until the E&S BMPs specified by the BMP sequence for that stage or phase have been installed and are functioning as described in this E&S plan.
- At no time shall construction vehicles be allowed to enter areas outside the limit of disturbance boundaries shown on the plan maps. These areas must be clearly marked and fenced off before clearing and grubbing operations begin.
- Topsoil required for the establishment of vegetation shall be stockpiled at the location(s) shown on the plan maps in the amount necessary to complete the final grading of all exposed areas that are to be stabilized by vegetation. Each stockpile shall be protected in the manner shown on the plan drawings. Stockpile heights shall not exceed 35 feet. Stockpile slopes shall be 2:1:V or flatter.
- Immediately upon discovering unforeseen circumstances posing the potential for accelerated erosion and/or sediment pollution, the operator shall implement appropriate best management practices to minimize the potential for erosion and sediment pollution and notify the local conservation district and/or the Department of the Department of Environmental Protection.
- All building materials and wastes shall be removed from the site and recycled or disposed of in accordance with the Department's Solid Waste Management Regulations at 25 Pa. Code 260.1 et seq., 271.1, and 287.1 et seq. No building materials or wastes or unused building materials shall be burned, buried, dumped, or otherwise disposed at the site.
- All off-site waste and borrow areas must have an E&S plan approved by the local conservation district or the Department fully implemented prior to being activated.
- The contractor is responsible for ensuring that any material brought on site is clean fill. Form FP-001 must be retained by the property owner for any fill material affected by a spill or release of a regulated substance but qualifying as clean fill due to analytical testing.
- All pumping of water from any work area shall be done according to the procedure described in this plan, over undisturbed vegetated areas.
- Vehicles and equipment may neither enter directly nor exit directly from lot onto Lime Street.
- Until the site is stabilized, all erosion and sediment BMPs shall be maintained properly. Maintenance shall include inspections of all erosion and sediment BMPs after each runoff event and on a weekly basis. All preventative and remedial maintenance work, including clean out, repair, replacement, regrading, reseeding, removing and renetting must be performed immediately. If the E&S BMPs fail to perform as expected, replacement BMPs, or modifications of those installed will be required.
- A log showing dates that E&S BMPs were inspected as well as any deficiencies found and the date they were corrected shall be maintained on the site and be made available to regulatory agency officials at the time of inspection.
- Sediment tracked onto any public roadway or sidewalk shall be returned to the construction site by the end of each work day and disposed in the manner described in this plan. In no case shall the sediment be washed, shoveled, or swept into any roadside ditch, storm sewer, or surface water.
- All sediment removed from BMPs shall be disposed of in the manner described on the plan drawings.
- Areas which are to be topsoiled shall be scarified to a minimum depth of 3 to 5 inches -- 6 to 12 inches on compacted soils -- prior to placement of topsoil. Areas to be vegetated shall have a minimum 4 inches of topsoil in place prior to seeding and mulching. Fill outlopes shall have a minimum of 2 inches of topsoil.
- All fills shall be compacted as required to reduce erosion, slippage, settlement, subsidence or other related problems. Fill intended to support buildings, structures and conduits, etc. shall be compacted in accordance with local requirements or codes.
- All earthen fills shall be placed in compacted layers not to exceed 9 inches in thickness.
- Fill materials shall be free of frozen particles, brush, roots, sod, or other foreign or objectionable materials that would interfere with or prevent construction of satisfactory fills.
- Frozen materials or soft, muddy, or highly compressible materials shall not be incorporated into fills.
- Fill shall not be placed on saturated or frozen surfaces.
- Seeps or springs encountered during construction shall be handled in accordance with the standard and specification for subsurface drain or other approved method.
- All graded areas shall be permanently stabilized immediately upon reaching finished grade. Cut slopes in competent bedrock and rock fills need not be vegetated. Seeded areas within 50 feet of a surface water, or as otherwise shown on the plan drawings, shall be blanketed according to the standards of this plan.
- Immediately after earth disturbance activities cease in any area or subarea of the project, the operator shall stabilize all disturbed areas. During non-permitting months, mulch or protective blanketing shall be applied as described in the plan. Areas not at finished grade, which will be reactivated within 1 year, may be stabilized in accordance with the temporary stabilization specifications. Those areas which will not be reactivated within 1 year shall be stabilized in accordance with the permanent stabilization specifications.
- Permanent stabilization is defined as a minimum uniform, perennial 70% vegetative cover or other permanent non-vegetative cover with a density sufficient to resist accelerated erosion. Cut and fill slopes shall be capable of resisting failure due to slumping, sliding, or other movements.
- E&S BMPs shall remain functional as such until all areas tributary to them are permanently stabilized or until they are replaced by another BMP approved by the local conservation district or the Department.
- Upon completion of all earth disturbance activities and permanent stabilization of all disturbed areas, the owner and/or operator shall contact the local conservation district for an inspection prior to removal/conversion of the E&S BMPs.
- After final site stabilization has been achieved, temporary erosion and sediment BMPs must be removed or converted to permanent post construction stormwater management BMPs. Areas disturbed during removal or conversion of the BMPs shall be stabilized immediately. In order to ensure rapid revegetation of disturbed areas, such removal/conversions are to be done only during the germinating season.
- Upon completion of all earth disturbance activities and permanent stabilization of all disturbed areas, the owner and/or operator shall contact the local conservation district to schedule a final inspection.
- Failure to correctly install E&S BMPs, failure to prevent sediment-laden runoff from leaving the construction site, or failure to take immediate corrective action to resolve failure of E&S BMPs may result in administrative, civil, and/or criminal penalties being instituted by the Department as defined in Section 602 of the Pennsylvania Clean Streams Law. The Clean Streams Law provides for up to \$10,000 per day in civil penalties, up to \$10,000 in summary criminal penalties, and up to \$25,000 in misdemeanor criminal penalties for each violation.

SEQUENCE OF CONSTRUCTION

- PRE-CONSTRUCTION MEETING IS REQUIRED PRIOR TO ANY EARTH DISTURBANCE.
- CONTRACTOR SHALL INITIATE CONSTRUCTION BY FENCING OFF AREA PRIOR TO ANY EARTH DISTURBANCE.
- INSTALL THE SILT FENCE AND THE STONE CONSTRUCTION ENTRANCE.
- BEFORE ROUGH GRADING OF SITE, IN AREAS ADJACENT TO THE ROADWAY/RIGHT-OF-WAY WHERE GRADING OR DEMOLITION MAY ENDOUR ON THE SILT FENCE, THE CONTRACTOR IS TO IMMEDIATELY REPLACE OR REPAIR ANY SILT FENCE THAT IS DISTURBED DURING GRADING. ALL SILT FENCE MUST BE IN WORKING CONDITION AT THE END OF EACH WORKING DAY.
- CONSTRUCTION OF THE BUILDING CAN COMMENCE AND CONTINUE THROUGH COMPLETION.
- INSTALL PROPOSED LANDSCAPING AND SEEDING MATERIAL AND CLEAR ANY UNWANTED DEBRIS AND MISCELLANEOUS CONSTRUCTION MATERIAL.
- UPON STABILIZATION OF THE SITE, CONTRACTOR SHALL REMOVE ALL REMAINING EROSION AND SEDIMENTATION CONTROL MEASURES. THE AREA IS CONSIDERED PERMANENTLY STABILIZED WHEN A UNIFORM 70% VEGETATIVE COVER OF EROSION RESISTANT PERENNIAL SPECIES HAS BEEN ACHIEVED. ANY SEDIMENT SHALL BE REMOVED TO FINAL GRADES, UNTIL SUCH TIME THAT THE ENTIRE AREA HAS ACHIEVED THIS STANDARD. INTERIM STABILIZATION MEASURES AND TEMPORARY EROSION AND SEDIMENT CONTROL FEATURES THAT ARE USED TO TREAT PROJECT RUNOFF MAY NOT BE REMOVED.

LEGEND & ABBREVIATIONS

---	PROPERTY BOUNDARY	⊙	STORM MANHOLE
---	ADJACENT BOUNDARY	⊙	SANITARY MANHOLE
---	RIGHT OF WAY LINE	⊙	COMMUNICATION MANHOLE
---	BUILDING SETBACK LINE	⊙	ELECTRIC MANHOLE
---	EXISTING CONTOUR	⊙	WATER MANHOLE
---	EXISTING SPOT ELEVATION	⊙	UNKNOWN MANHOLE
---	EXISTING TREELINE	⊙	TANK LID
---	EXISTING FENCE	⊙	STORM INLET
---	EXISTING OVERHEAD WIRE	⊙	GAS METER
---	EXISTING CURB	⊙	WATER METER
---	EXISTING DEPRESSED CURB (DC)	⊙	TRAFFIC SIGNAL BOX
---	EXISTING SIGN	⊙	ELECTRIC VAULT
---	EXISTING UTILITY POLE (UP)	⊙	GAS VALVE
---	LANDSCAPE AREA	⊙	WATER VALVE
---	LAMP POST	⊙	CLEAN OUT
---	BENCHMARK	⊙	MONITORING WELL
---	DEED	⊙	

GRAPHIC SCALE

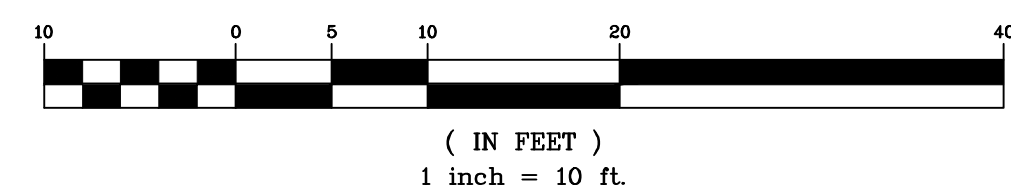

Cornerstone
Consulting Engineers & Architectural, Inc.

213 West Main Street - Lansdale - PA 19380
Phone: 215-362-2600 - Fax: 215-362-8400
WWW.CORNERSTONEINC.COM

Pocomo Region
570-839-1770

Philadelphia Region
215-362-2600

NO.	BY	DESCRIPTION	DATE

PENNSYLVANIA ONE CALL SYSTEM, INC.
925 First Run Road
West Mifflin, Pennsylvania
15122-1078

BEFORE YOU DIG ANYWHERE IN PENNSYLVANIA! CALL 1-800-242-1776
SN: 2021071243

NON-MEMBERS MUST BE CONTACTED DIRECTLY
PA LAW REQUIRES THREE WORKING DAYS NOTICE TO UTILITIES BEFORE YOU EXCAVATE, DRILL, BLAST OR DEMOLISH

J.B. ANDERSON
PROFESSIONAL ENGINEER
REG. NO. PE 005536
PENNSYLVANIA LICENSE NO. PE 005536
NEW JERSEY LICENSE NO. 24684520400
VIRGINIA LICENSE NO. 6082 045725

PROJECT LOCATION

BORKOWSKI HOMES PRESENTS WESTY PROJECT

931 SPRING MILL AVENUE, LLC
927-31 SPRING MILL AVENUE
WHITEMARSH TOWNSHIP
MONTGOMERY COUNTY
COMMONWEALTH OF PENNSYLVANIA

TITLE

EROSION & SEDIMENTATION PLAN

PROJ. #	21-4231	DATE	12-30-2021
CAD. ID.	21-4231	DRN. BY	EMR
SCALE	AS NOTED	CHK. BY	IBA

SHEET 5 OF 10

REVISION 0

REVISIONS

NO.	BY	DESCRIPTION	DATE

ONE CALL SYSTEM, INC.
925 Evans Road
West Mifflin, Pennsylvania
15122-1078

BEFORE YOU DIG ANYWHERE IN PENNSYLVANIA! CALL 1-800-242-1776
SN: 20210471243

NON-MEMBERS MUST BE CONTACTED DIRECTLY
PA LAW REQUIRES THREE WORKING DAYS NOTICE TO UTILITIES BEFORE YOU EXCAVATE, DRILL, OR TEST FOR DEMOLISH

J.B. ANDERSON
PROFESSIONAL ENGINEER
TRAIL & ART TERRACE, No. PE 1543
PENNSYLVANIA LICENSE No. PE 055536
NEW JERSEY LICENSE No. 29133
NEW YORK LICENSE No. 2468452400
VIRGINIA LICENSE No. 6002405725

PROJECT LOCATION

BORKOWSKI HOMES PRESENTS WESTY PROJECT

931 SPRING MILL AVENUE, LLC
927-31 SPRING MILL AVENUE
WHITEMARSH TOWNSHIP
MONTGOMERY COUNTY
COMMONWEALTH OF PENNSYLVANIA

TITLE

LANDSCAPE PLAN

PROJ. #	21-0231	DATE	12-30-2021
CAD. ID.	21-0231	DRN. BY	EMR
SCALE	AS NOTED	CHK. BY	JBA

SHEET 8 OF 10

REVISION 0

PLANT SCHEDULE

FLOWERING TREES	CODE	BOTANICAL / COMMON NAME	SIZE	CONTAINER	QTY	
	CC	Cercis canadensis / Eastern Redbud	6' Ht.	B&B	3	
	CF	Cornus florida / Flowering Dogwood	6' Ht.	B&B	3	
EVERGREEN TREES	CODE	BOTANICAL / COMMON NAME	SIZE	CONTAINER	QTY	
	TX	Thuja x Green Giant / Green Giant Arborvitae	4' Ht.	B&B	17	
DECIDUOUS SHRUBS	CODE	BOTANICAL / COMMON NAME	SIZE	CONTAINER	QTY	
	Hq	Hydrangea quercifolia / Oakleaf Hydrangea	18" Ht.	Pot	12	
EVERGREEN SHRUBS	CODE	BOTANICAL / COMMON NAME	SIZE	CONTAINER	QTY	
	lc	Ilex crenata 'Helleri' / Heller's Japanese Holly	24" ht.	Pot	13	
	lv	Ilex verticillata / Winterberry	24" ht.	Pot	23	
	Po	Prunus laurocerasus 'Otto Luyken' / Otto Luyken English Laurel	24" ht.	Pot	3	
	Vd	Viburnum dentatum / Arrowwood Viburnum	24" ht.	Pot	3	
PERENNIALS	CODE	BOTANICAL / COMMON NAME	SIZE	CONTAINER	QTY	
	Ck	Calamagrostis x acutiflora 'Karl Foerster' / Karl Foerster Feather Reed Grass	2 gal.	Pot	6	
	hp	Hosta x 'Patriot' / Patriot Hosta	#1	Pot	26	
PERENNIALS	CODE	BOTANICAL / COMMON NAME	SIZE	CONTAINER	SPACING	QTY
	he	Hemerocallis x 'Happy Returns' / Happy Returns Daylily	#SP4	Pot	18" o.c.	65
	vc	Vinca minor / Common Periwinkle	#SP2	Pot	12" o.c.	743

- LANDSCAPE NOTES:**
- EXISTING TREES NEAR PROPOSED IMPROVEMENTS SHALL BE PROTECTED WITH TREE PROTECTION FENCE. REFER TO THE PLAN VIEW FOR THE GENERAL LOCATION.
 - LOCATION OF ALL UNDERGROUND UTILITIES SHALL BE VERIFIED AND MARKED IN THE FIELD, PRIOR TO ANY DIGGING OPERATIONS.
 - PLANT MATERIAL SHALL BE FURNISHED AND INSTALLED AS INDICATED INCLUDING ALL LABOR, MATERIALS, PLANTS, EQUIPMENT, AND CLEAN-UP WHICH ARE INCIDENTAL TO LANDSCAPE INSTALLATION.
 - THE CONTRACTOR SHALL BE RESPONSIBLE FOR PLANTING AT THE CORRECT GRADES AND ALIGNMENTS. ALL PLANTS SHALL BE SET PLUMB AND STRAIGHT. LANDSCAPING SHALL BE INSTALLED IN THE CENTER OF THE PIT.
 - ALL PLANTS SHALL CONFORM WITH THE MOST CURRENT VERSION OF THE "AMERICAN STANDARD FOR NURSERY STOCK" OF THE AMERICAN NURSERY AND LANDSCAPE ASSOCIATION.
 - ALL PLANT MATERIAL SHALL BE GUARANTEED FOR A PERIOD OF EIGHTEEN MONTHS.
 - CONTRACTOR SHALL REPAIR ANY SOIL OR SUBSURFACE DRAINAGE WHICH MAY BE DETRIMENTAL TO GROWTH OF THE PLANT MATERIAL.
 - ALL TREES SHALL BE PROVIDED WITH A 3" DEEP SAUCER, CONSISTING OF SHREDDED OAK BARK MULCH.
 - ALL SHRUB BEDS SHALL BE PROVIDED WITH A 3" DEEP LAYER OF SHREDDED OAK BARK MULCH.
 - INsofar AS PRACTICAL, PLANT MATERIAL SHALL BE PLANTED ON THE DAY OF DELIVERY, IN THE EVENT THAT THIS IS NOT POSSIBLE THE CONTRACTOR PROTECT THE LANDSCAPING NOT PLANTED AND ENSURE IT RECEIVES ADEQUATE WATERING UNDER NO CIRCUMSTANCES SHALL LANDSCAPING REMAIN UNPLANTED FOR MORE THAN THREE (3) DAYS.
 - ALL PLANTS SHALL BE PLANTED IN TOPSOIL THAT IS THOROUGHLY WATERED AND TAMPED AS BACKFILLING PROGRESSES.
 - INSTALLATION OF PLANTS SHALL OCCUR WITHIN THE PLANTING SEASON WHEN WETTER AND SOIL CONDITIONS ARE SUITABLE.
 - ALL PLANTS SHALL BE THOROUGHLY WATERED BY THE CONTRACTOR AT LEAST THREE (3) TIMES (IN THE ABSENCE OF NATURAL RAINFALL), PRIOR TO ACCEPTANCE OF PLANTING BY THE OWNER.
 - ALL DISTURBED AREAS ARE TO BE FINE GRADED, BAKED, MULCHED AND SEEDDED.

LEGEND & ABBREVIATIONS

	PROPERTY BOUNDARY		STORM MANHOLE
	ADJOINER BOUNDARY		SANITARY MANHOLE
	RIGHT OF WAY LINE		COMMUNICATION MANHOLE
	BUILDING SETBACK LINE		ELECTRIC MANHOLE
	EXISTING CONTOUR		UNKNOWN MANHOLE
	EXISTING TREELINE		TANK LID
	EXISTING FENCE		STORM INLET
	EXISTING OVERHEAD WIRE		GAS METER
	EXISTING CURB		WATER METER
	EXISTING DEPRESSED CURB (DC)		TRAFFIC SIGNAL BOX
	EXISTING SIGN		ELECTRIC VAULT
	EXISTING UTILITY POLE (UP)		GAS VALVE
	LANDSCAPE AREA		WATER VALVE
	LAMP POST		CLEAN OUT
	BENCHMARK		MONITORING WELL
	DEED		

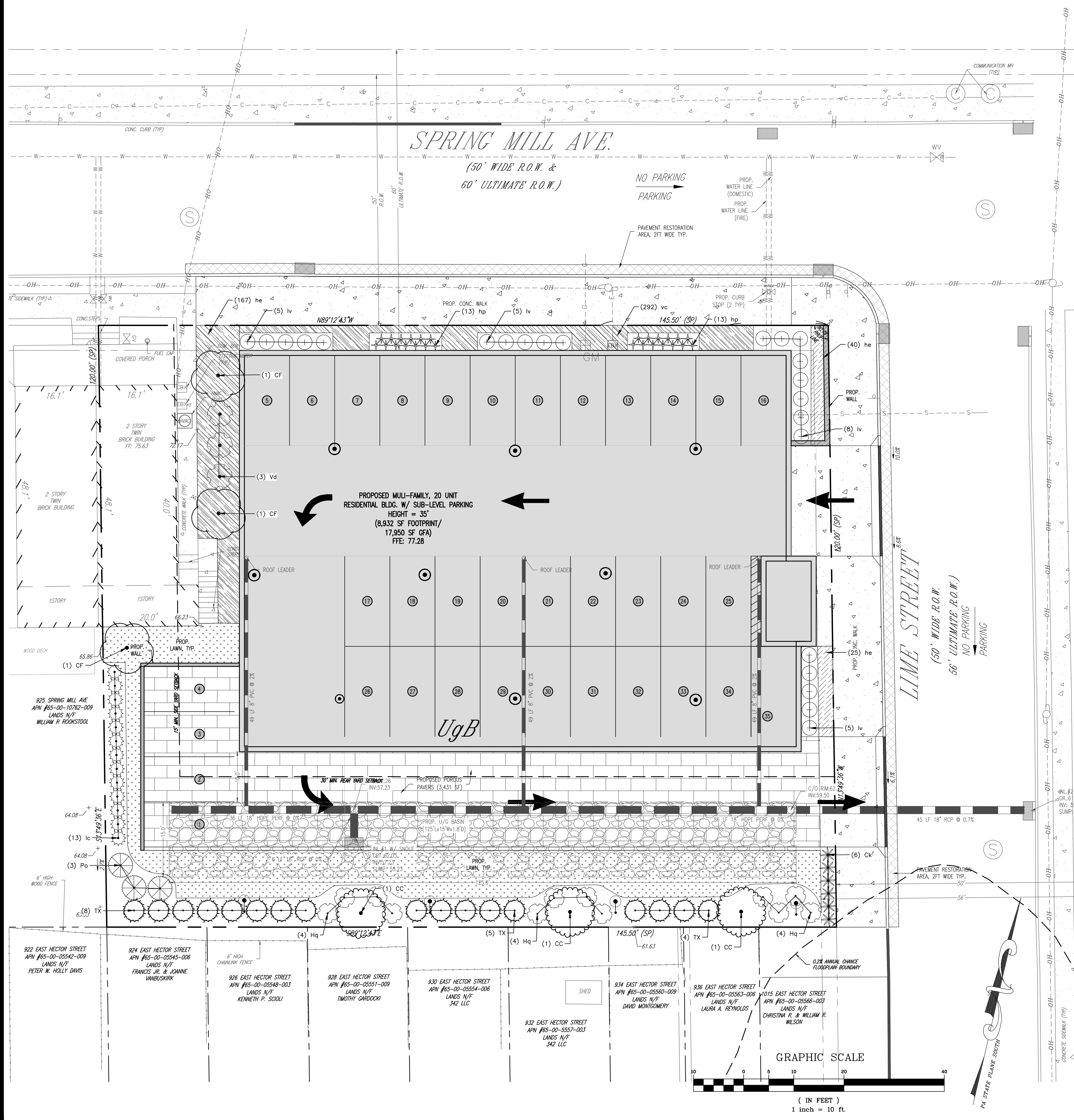

GRAPHIC SCALE
(IN FEET)
1 inch = 10 ft.

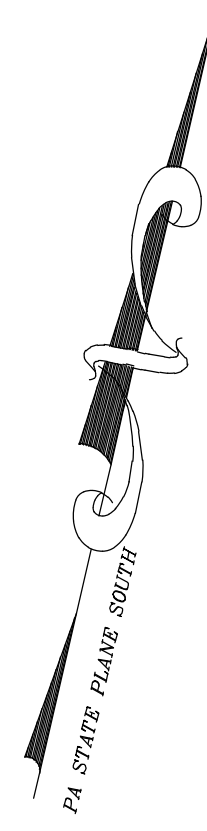
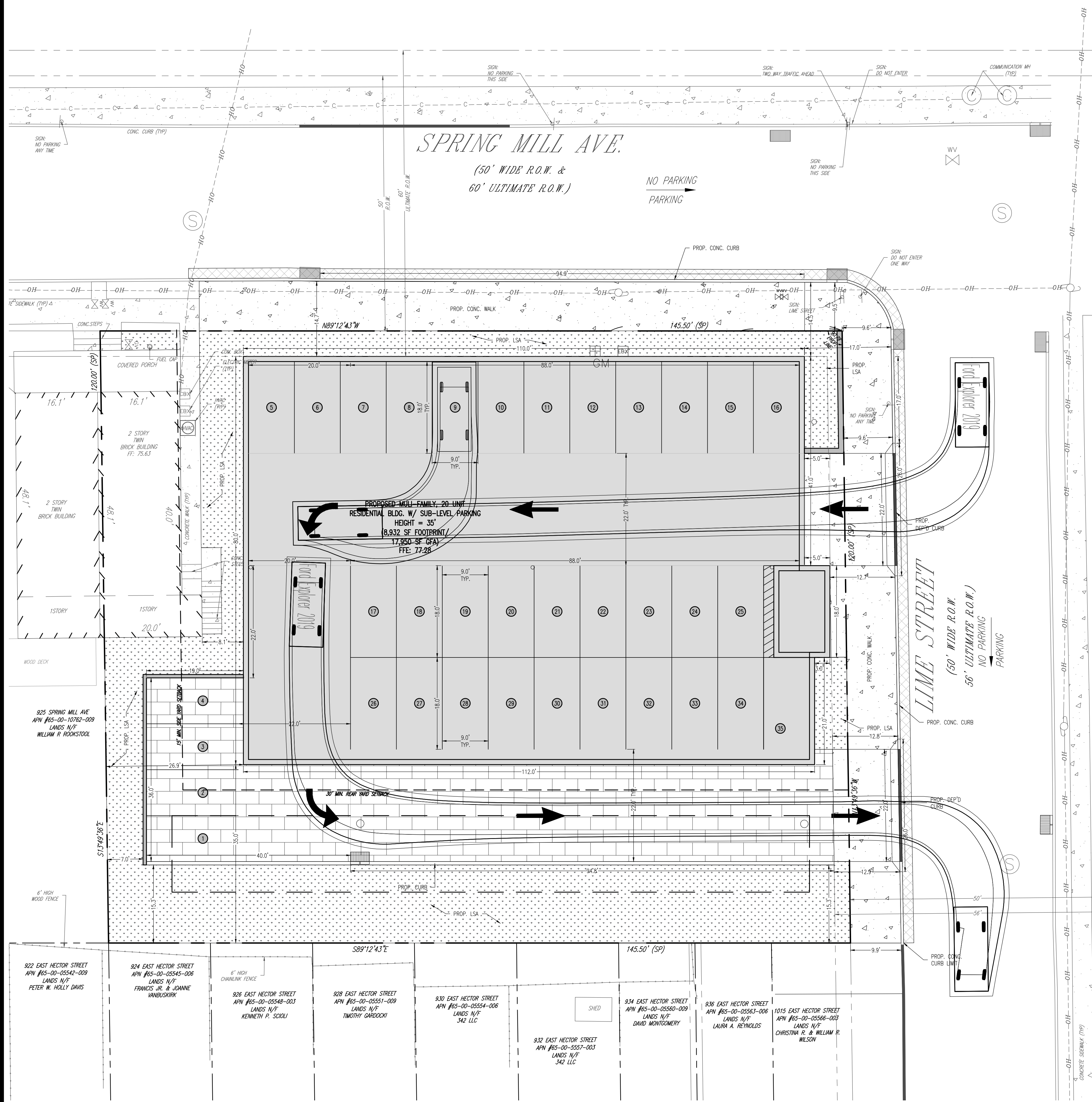

GENERAL NOTES

1. THIS PLAN IS PREPARED TO INDICATE THE ABILITY OF VARIOUS VEHICLES TO MANUEVER THROUGH THE PROPOSED FACILITY. IT IS PREPARED WITH THE BENEFIT OF "AUTODESK VEHICLE TRACKING 2014". AUTODESK VEHICLE TRACKING PRODUCES GEOMETRICALLY IDEALIZED RESULTS THAT MAY BE DIFFICULT TO REPLICATE EXACTLY AND THE SIMULATION DOES NOT SUGGEST THAT OTHER DRIVEABLE PATHS BETWEEN DESIRED START AND END POSITIONS ARE NOT POSSIBLE. THE SIMULATIONS SHOWN IN THE SCHEMATICS ARE FOR PLANNING PURPOSES AND ARE USED TO DETERMINE POSSIBLE TRAVEL PATHS.
2. THE SIMULATIONS IN THE SCHEMATICS ARE CHOSEN DUE TO THE RELATIVE DIFFICULTY OF THE MANUEVER. NOT ALL TURNING SITUATIONS WERE ANALYZED, AND THOSE SITUATIONS NOT SHOWN ARE ASSUMED TO BE ADEQUATE.
3. THE MIDSIZE VEHICLE WAS CHOSEN TO DETERMINE THE ABILITY TO MANUEVER VEHICLES THROUGH THE PROPOSED FACILITY.

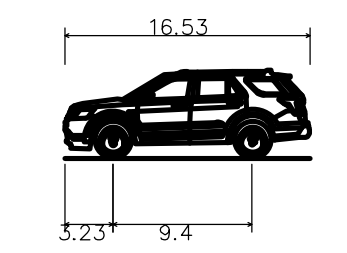

Ford Explorer 2019
Overall Length 16.530ft
Overall Width 6.580ft
Overall Body Height 5.936ft
Min Body Ground Clearance 0.651ft
Track Width 5.583ft
Lock-to-lock time 4.00s
Curb to Curb Turning Radius 19.600ft

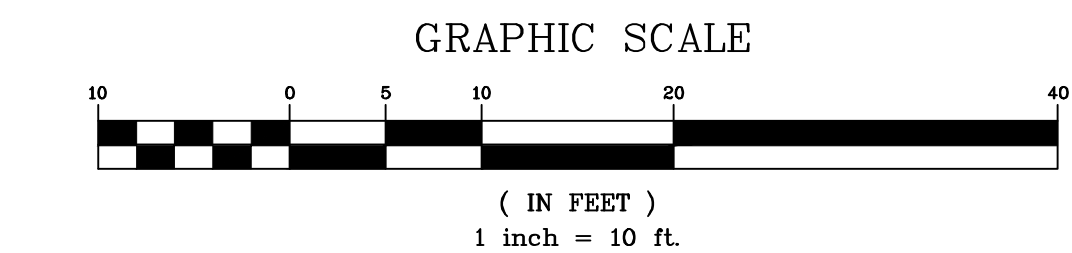

NO	BY	DESCRIPTION	DATE

PENNSYLVANIA ONE CALL SYSTEM, INC.
925 Evans Road
West Mifflin, Pennsylvania 15122-1078

BEFORE YOU DIG ANYWHERE IN PENNSYLVANIA! CALL 1-800-242-1776
SN: 2021071243
NON-MEMBERS MUST BE CONTACTED DIRECTLY
PA LAW REQUIRES THREE WORKING DAYS NOTICE TO UTILITIES BEFORE YOU EXCAVATE, DRILL, BLAST OR DEMOLISH

J.B. ANDERSON
PROFESSIONAL ENGINEER
ILLINOIS LICENSE NO. PE 1543
PENNSYLVANIA LICENSE NO. PE 055536
NEW JERSEY LICENSE NO. 24684520400
VIRGINIA LICENSE NO. 600245725

PROJECT LOCATION

BORKOWSKI HOMES PRESENTS WESTY PROJECT
931 SPRING MILL AVENUE, LLC
927-31 SPRING MILL AVENUE
WHITEMARSH TOWNSHIP
MONTGOMERY COUNTY
COMMONWEALTH OF PENNSYLVANIA

TITLE

TURNING PLAN

PROJ.#	21-0231	DATE	12-30-2021
CAD ID.	21-0231	DRN BY	EMR
SCALE	AS NOTED	CHK BY	JBA
SHEET 9 OF 10			
REVISION 0			

NO.	BY	DESCRIPTION	DATE

ONE CALL SYSTEM, INC.
928 Birch Road
West Mifflin, Pennsylvania
15122-1078

BEFORE YOU DIG ANYWHERE IN PENNSYLVANIA! CALL 1-800-242-1776
SN: 20210471243
NON-MEMBERS MUST BE CONTACTED DIRECTLY
PA LAW REQUIRES THREE WORKING DAYS NOTICE TO UTILITIES BEFORE YOU EXCAVATE, DRILL, BLAST OR DEMOLISH

J.B. ANDERSON
PROFESSIONAL ENGINEER
P.E. LICENSE NO. PE 15438
PENNSYLVANIA LICENSE NO. PE 055536
* EXPIRES AND LICENSE NO. 2017
NEW JERSEY LICENSE NO. 24624530400
VIRGINIA LICENSE NO. 6401045725

PROJECT LOCATION

BORKOWSKI HOMES PRESENTS WESTY PROJECT

931 SPRING MILL AVENUE, LLC
927-31 SPRING MILL AVENUE
WHITEMARSH TOWNSHIP
MONTGOMERY COUNTY
COMMONWEALTH OF PENNSYLVANIA

TITLE

DETAILS

PROJ.#	21-0231	DATE	12-30-2021
CAD ID	21-0231	DRN BY	EMR
SCALE	AS NOTED	CHK BY	JBA

SHEET 10 OF 10

REVISION 0

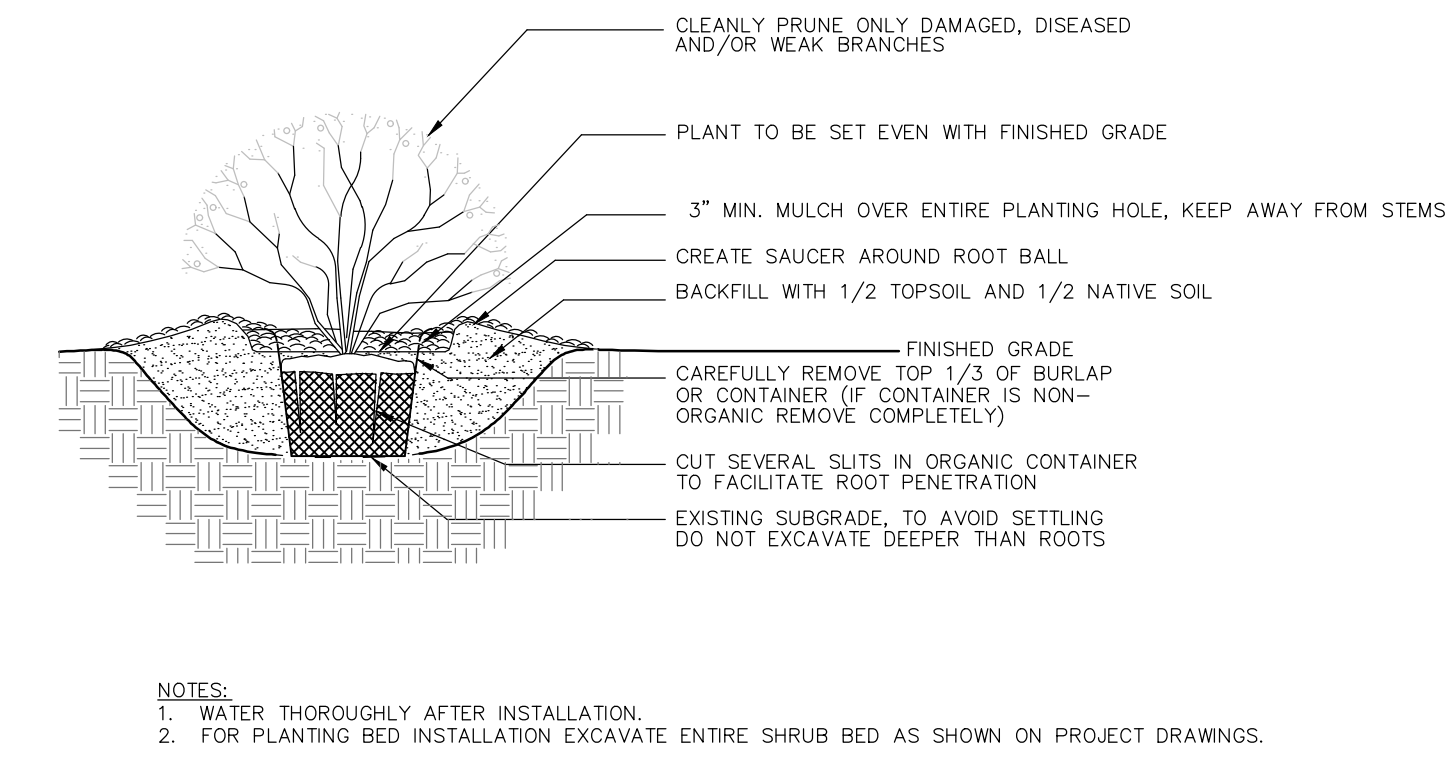

TYPICAL SHRUB PLANTING DETAIL
NOT TO SCALE

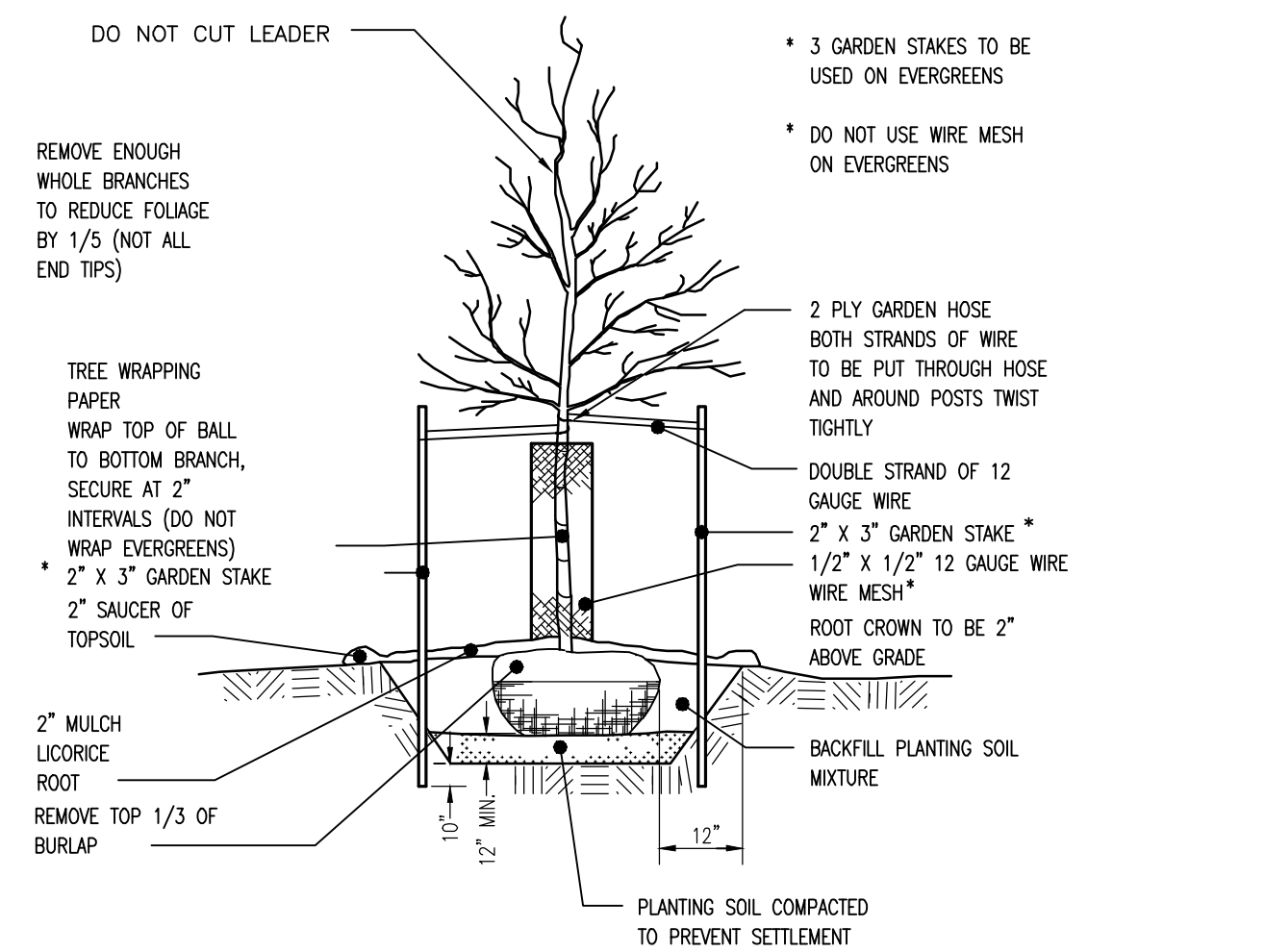

TREE PLANTING AND STAKING DETAIL
NOT TO SCALE

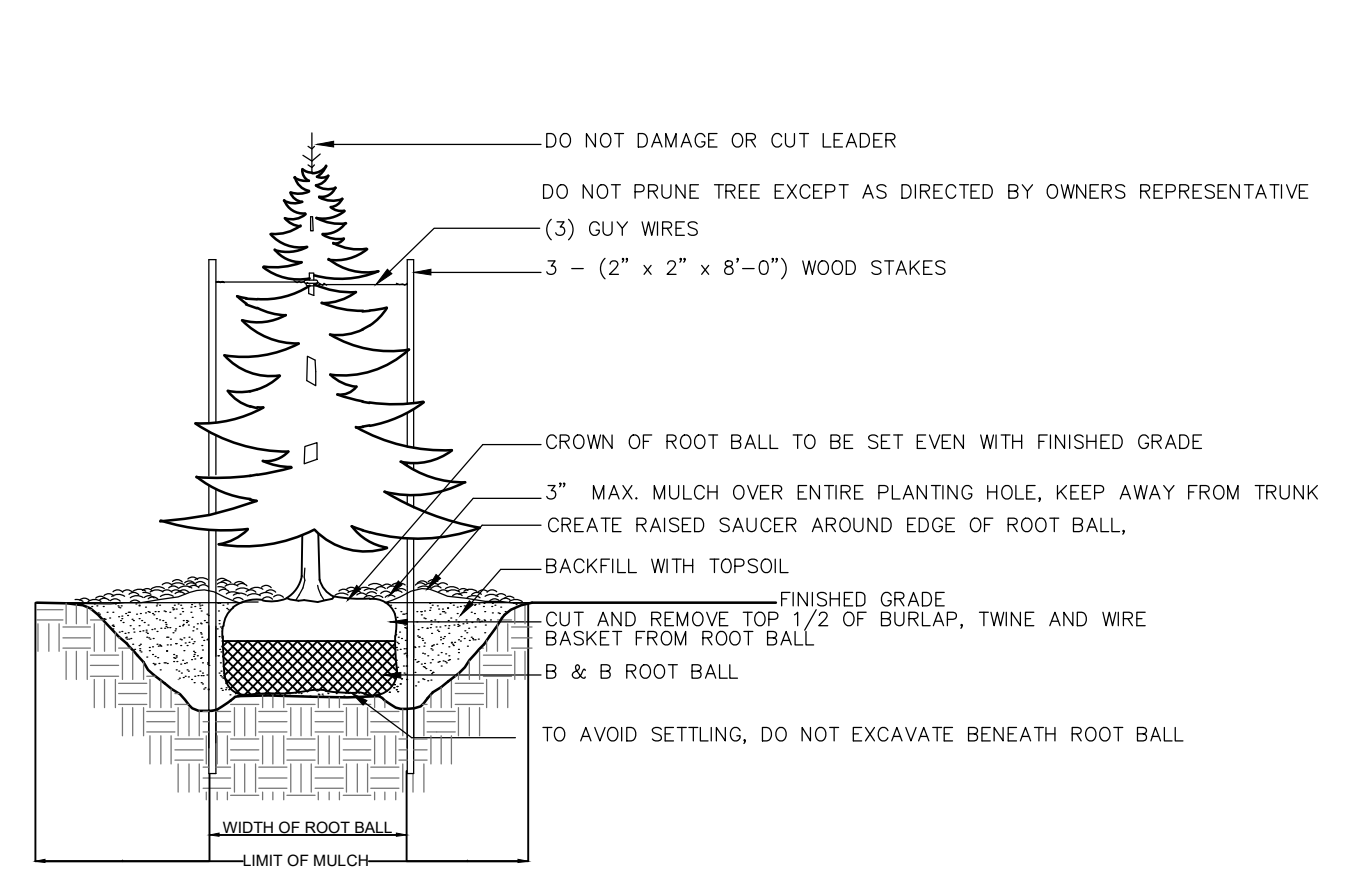

TYPICAL EVERGREEN TREE PLANTING DETAIL
NOT TO SCALE

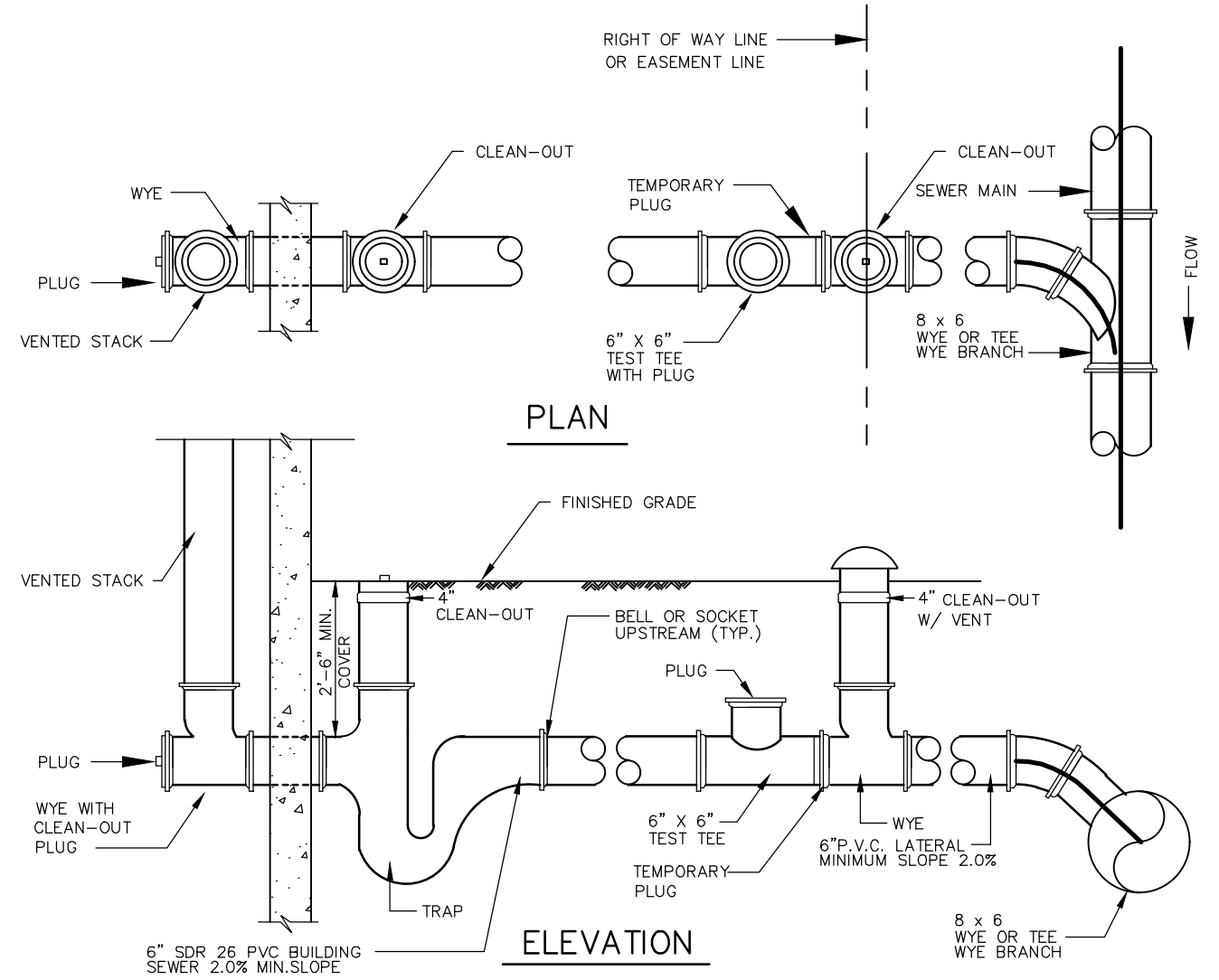

- NOTES:**
- BUILDING SEWER FROM RIGHT-OF-WAY LINE TO BUILDING PLUMBING SYSTEM SHALL CONFORM TO THE INTERNATIONAL PLUMBING CODE ADOPTED BY THE TOWNSHIP.
 - TEMPORARY PIPE PLUG TO REMAIN IN LATERAL UNTIL CONSTRUCTION OF BUILDING SEWER OCCURS. BUILDING SEWER SHALL BE PLUGGED AT TEST TEE UNTIL CONSTRUCTION IS COMPLETED AND TESTED.
 - PIPE TO BE EMBEDDED IN 18\"/>

SANITARY SEWER SERVICE CONNECTION
N.T.S.

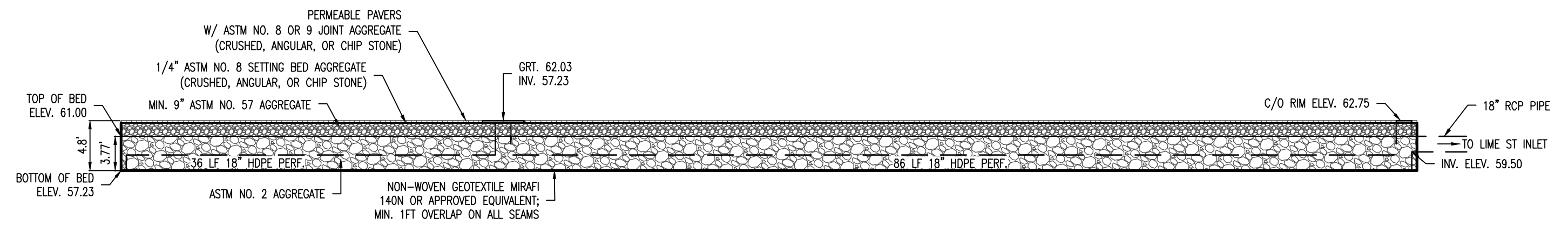

PERMEABLE PAVEMENT AND STORMWATER INFILTRATION BASIN DETAIL
SCALE: 1\"/>

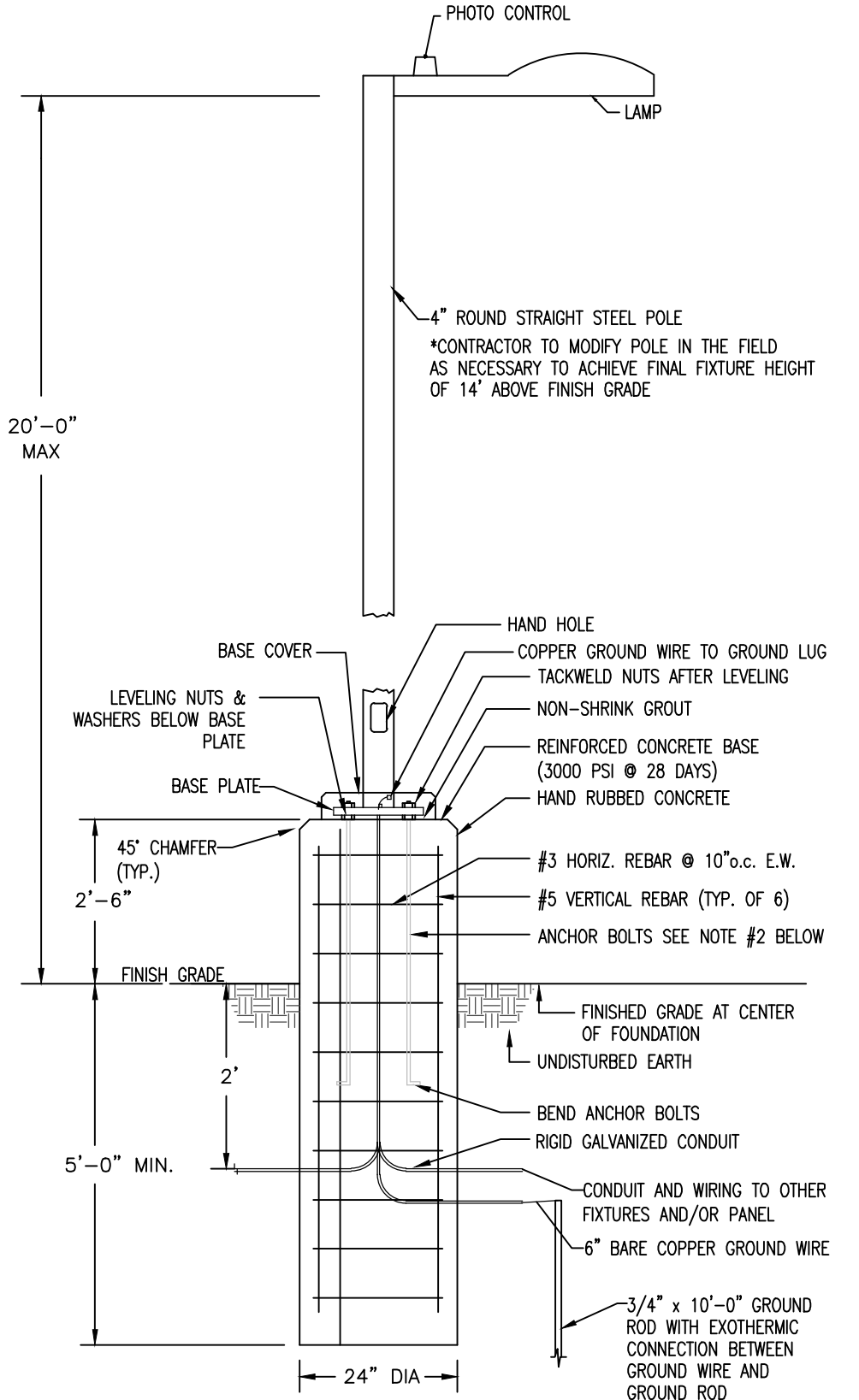

LIGHT POLE W/ STANDARD ANCHORING DETAIL
N.T.S.

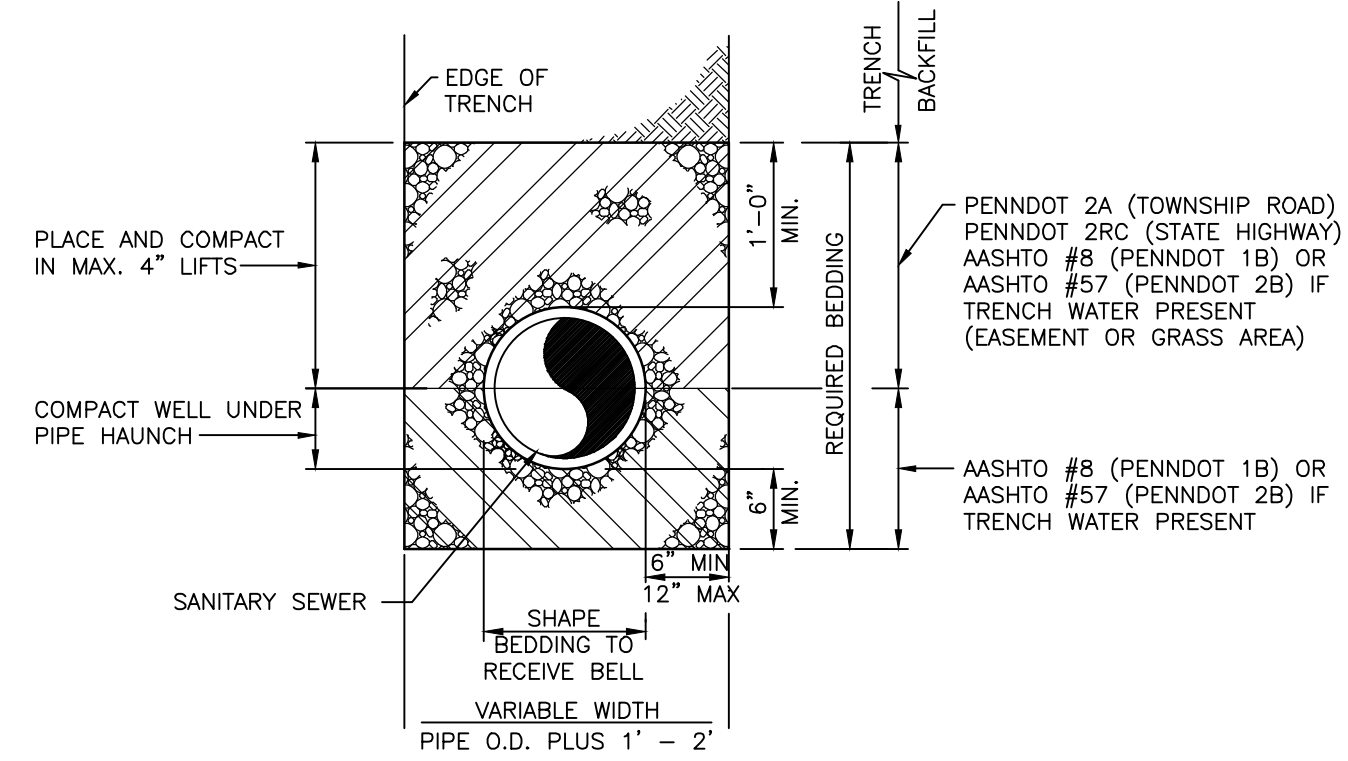

P.V.C. PIPE EMBEDMENT

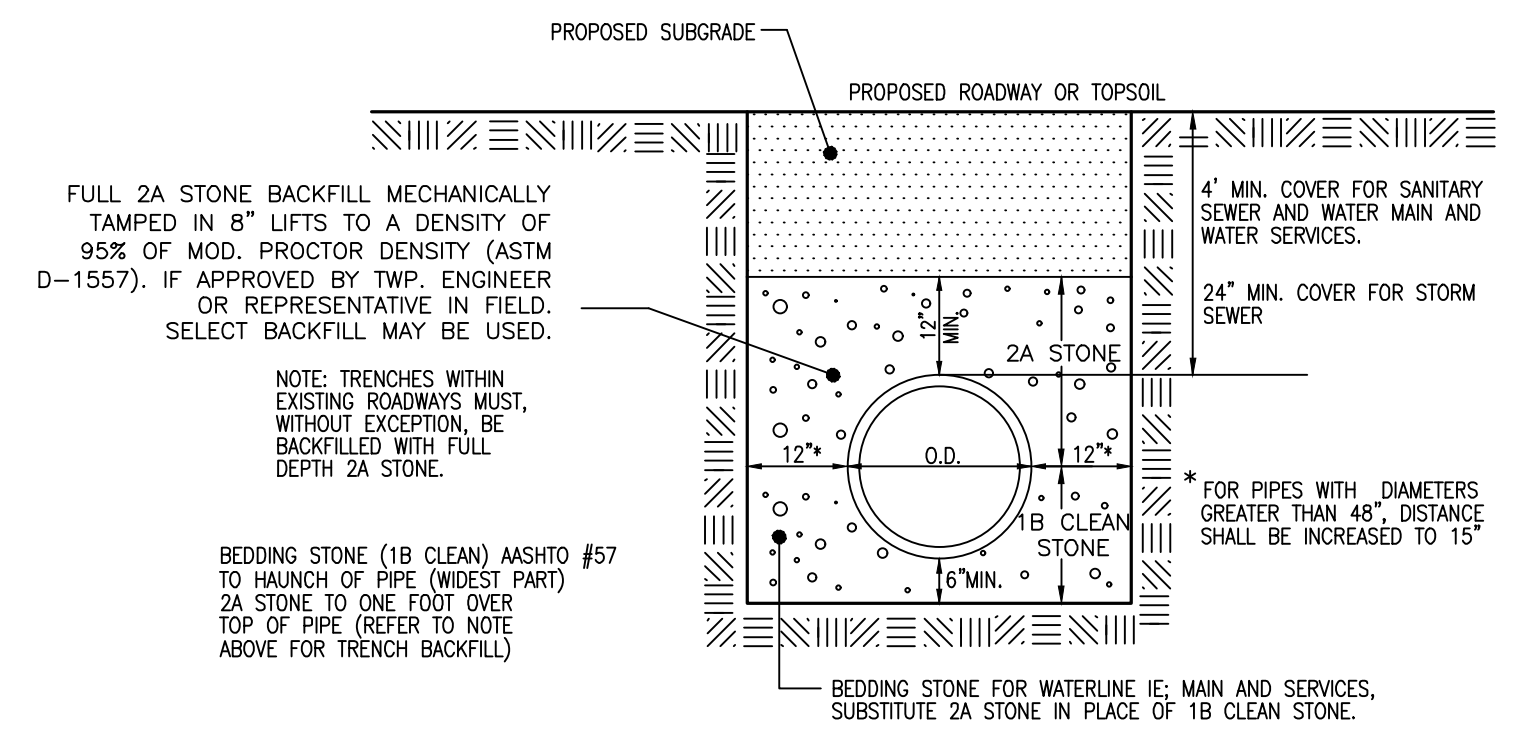

TYPICAL TRENCH DETAIL
NOT TO SCALE

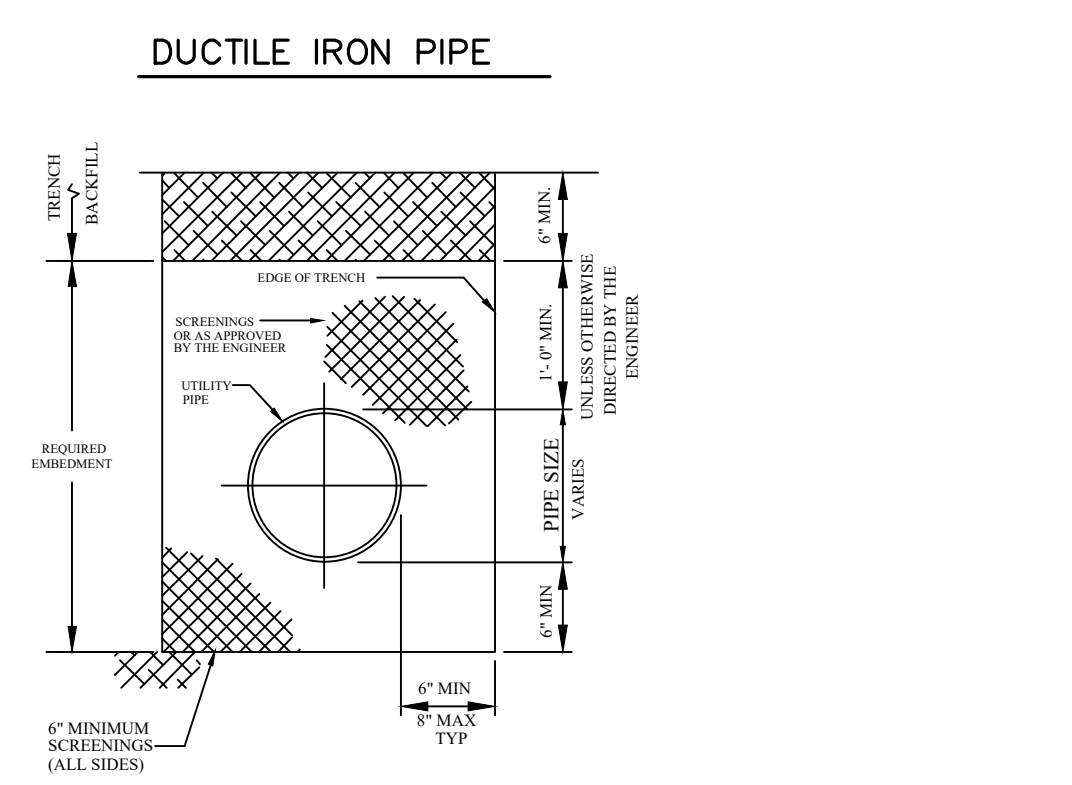

DUCTILE IRON PIPE
COPPER PIPE
PIPE EMBEDMENT
NOT TO SCALE

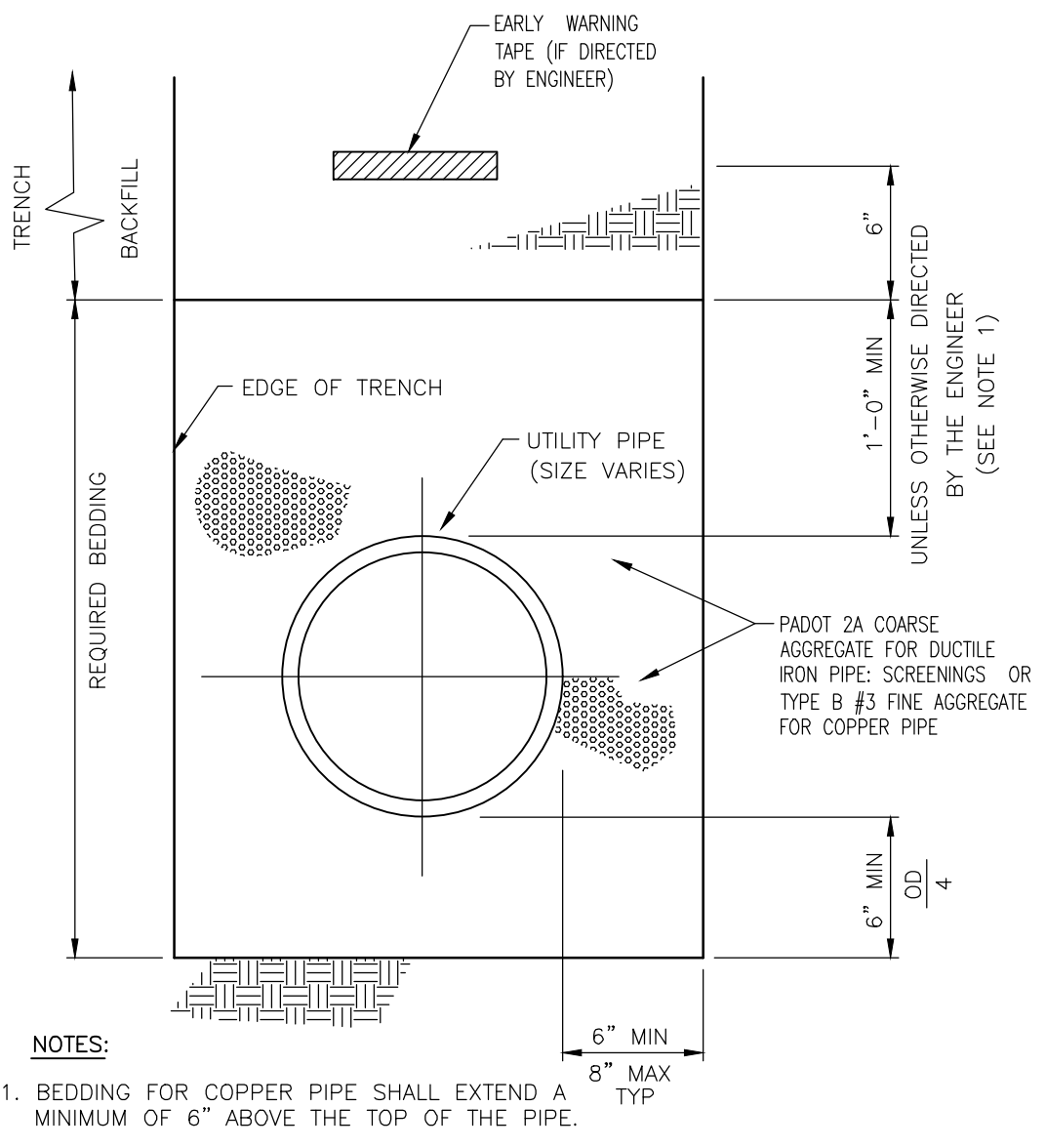

STANDARD PIPE BEDDING
NOT TO SCALE

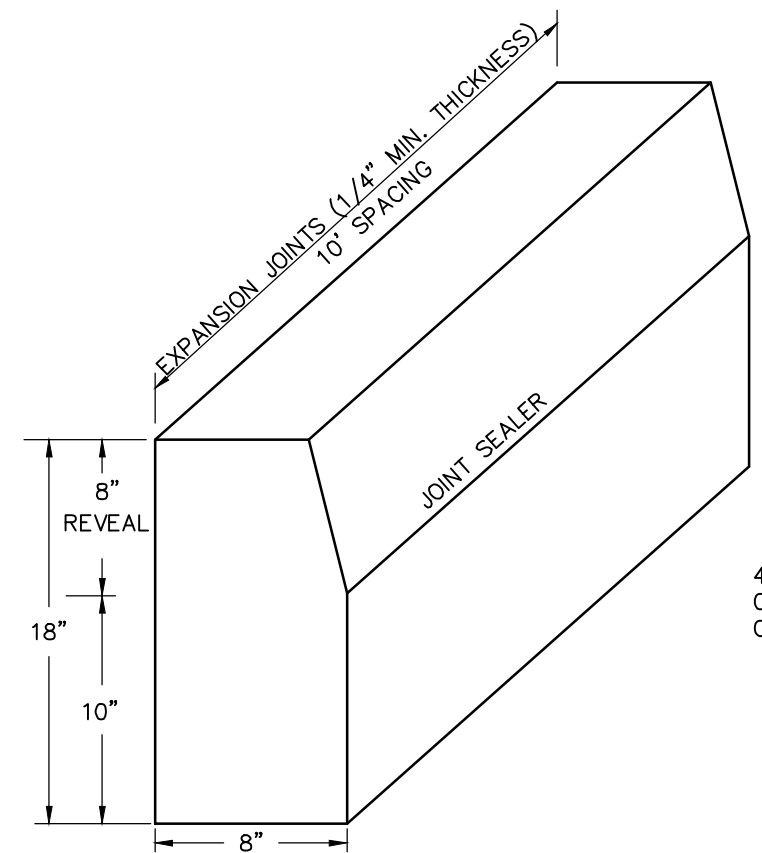

WATER CROSSINGS

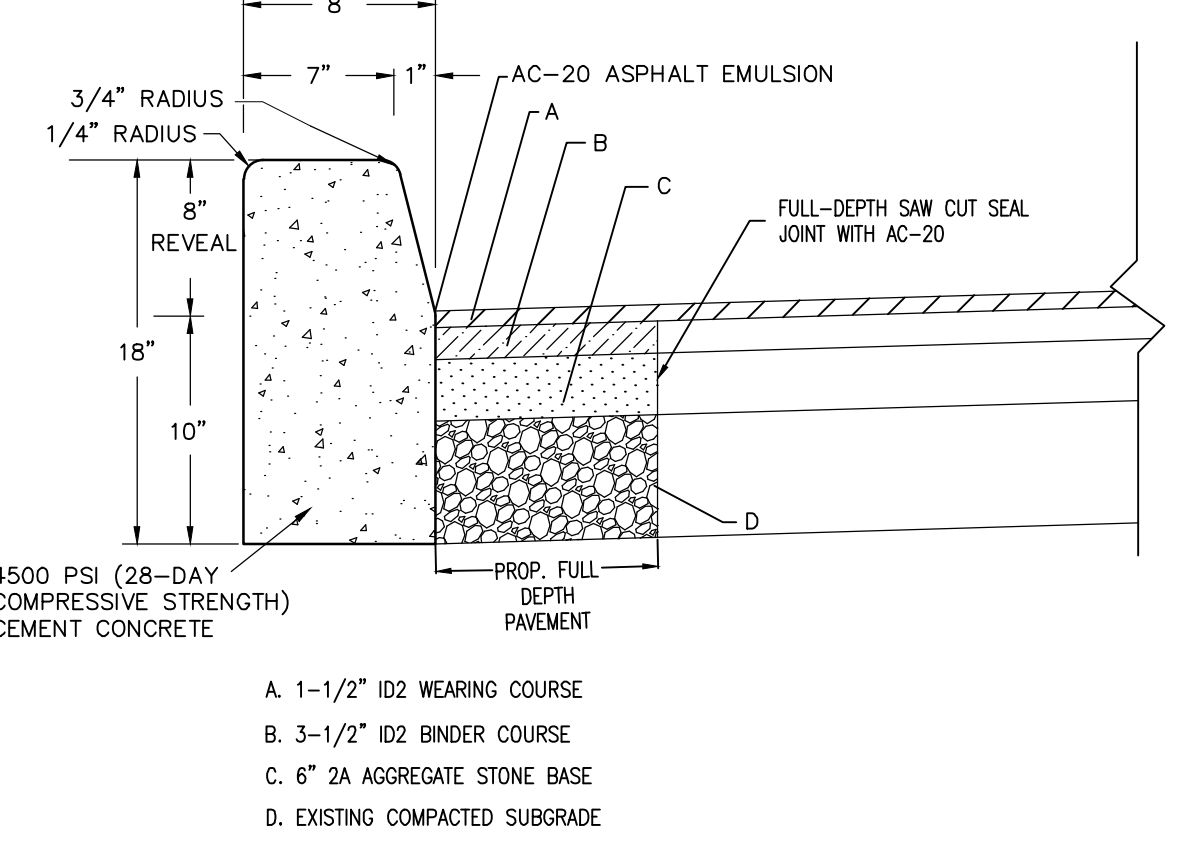

TYPICAL CONCRETE CURB AND PAVEMENT DETAIL
NOT TO SCALE

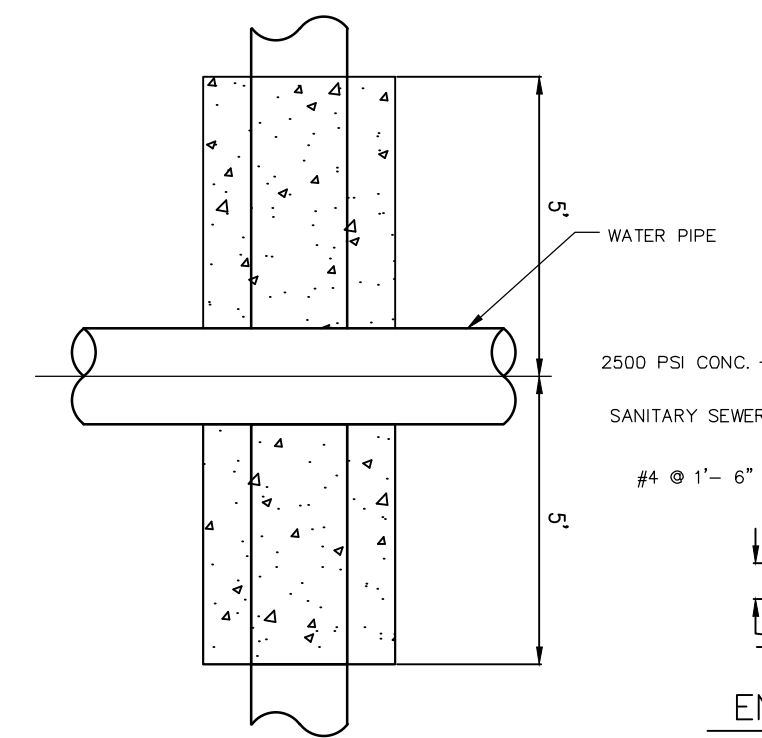

ENCASUREMENT SECTION

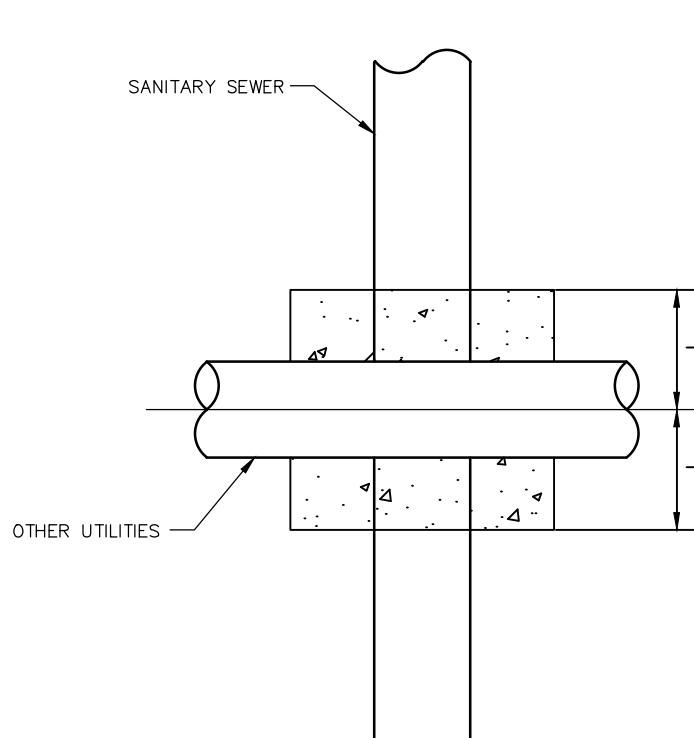

UTILITY CROSSINGS

CONCRETE ENCASUREMENT
N.T.S.

NOTE: ALL UTILITY TRENCHES WITHIN EXISTING ROADWAYS, PROPOSED ROADWAYS, ALL RIGHT OF WAYS, EASEMENTS, PROPOSED DRIVEWAYS, APRONS AND SIDEWALKS MUST, WITHOUT EXCEPTION, BE BACKFILLED WITH FULL DEPTH 2A STONE AFTER TOP SCREENING.

ALL UTILITY TRENCHES MUST BE COMPACTED (MECHANICALLY TAMPED) IN 8\"/>

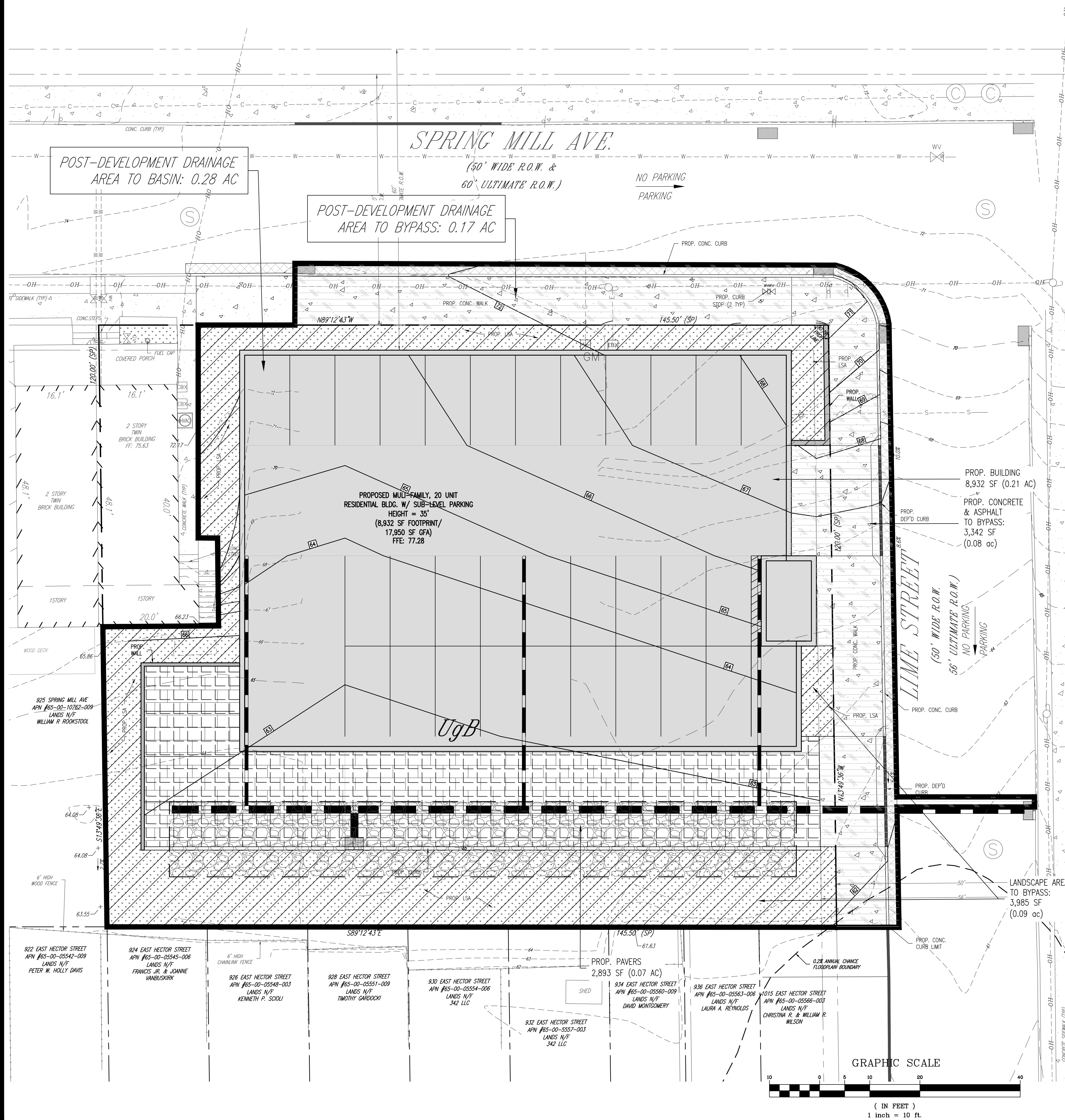

	PROPERTY BOUNDARY		STORM MANHOLE
	ADJOINER BOUNDARY		SANITARY MANHOLE
	RIGHT OF WAY LINE		COMMUNICATION MANHOLE
	BUILDING SETBACK LINE		ELECTRIC MANHOLE
	EXISTING CONTOUR		WATER MANHOLE
	EXISTING SPOT ELEVATION		UNKNOWN MANHOLE
	EXISTING TREELINE		TANK LID
	EXISTING FENCE		STORM INLET
	EXISTING OVERHEAD WIRE		GAS METER
	EXISTING CURB		WATER METER
	EXISTING DEPRESSED CURB (DC)		TRAFFIC SIGNAL BOX
	EXISTING SIGN		ELECTRIC VAULT
	EXISTING UTILITY POLE (UP)		GAS VALVE
	LANDSCAPE AREA		WATER VALVE
	LAMP POST		CLEAN OUT
	BENCHMARK		MONITORING WELL
	DEED		

Cornerstone
Consulting Engineers & Architectural, Inc.

213 West Main Street, Lansdale, PA 19446
Phone: 215-362-2600, Fax: 215-362-8400
WWW.CORNERSTONEINC.COM

Philadelphia Region
215-362-2600

Pocomo Region
570-834-1770

Lehigh Valley Region
610-830-5200

NO	BY	DESCRIPTION	DATE

PENNSYLVANIA
ONE CALL SYSTEM, INC.
925 Iron Run Road
West Mifflin, Pennsylvania
15122-1078

BEFORE YOU DIG ANYWHERE IN PENNSYLVANIA! CALL 1-800-242-1776
SN: 2021041243

NON-MEMBERS MUST BE CONTACTED DIRECTLY
PA LAW REQUIRES THREE WORKING DAYS NOTICE TO UTILITIES BEFORE YOU EXCAVATE, DRILL, BLAST OR DEMOLISH.

J.B. ANDERSON
PROFESSIONAL ENGINEER
DELAWARE LICENSE No. PE 1428
PENNSYLVANIA LICENSE No. PE 055536
NEW JERSEY LICENSE No. 24604520400
VIRGINIA LICENSE No. 6001045722

PROJECT LOCATION

BORKOWSKI HOMES PRESENTS WESTY PROJECT

931 SPRING MILL AVENUE, LLC
927-31 SPRING MILL AVENUE
WHITEMARSH TOWNSHIP
MONTGOMERY COUNTY
COMMONWEALTH OF PENNSYLVANIA

TITLE

POST-DEVELOPMENT DRAINAGE AREA PLAN

PROJ. #	21-0231	DATE	12-30-2021
CAD ID	21-0231	DRN BY	EMR
SCALE	AS NOTED	CHK BY	JBA

SHEET 2 OF 2

REVISION #



Fees and plans showing all public improvements are submitted with this application. Any additional plan information required by the Township Engineer will be submitted to the Director of Planning and Zoning for distribution. The undersigned applicant agrees to comply with all the provisions of Chapter 105 of the Code of the Township of Whitmarsh, as amended, and agrees to obtain all necessary permits in connection with the proposed subdivision and/or land development.

Whitmarsh Township employees, or township-authorized agents, are hereby granted permission to enter upon the land, if necessary, for site inspections.

Original preliminary and/or original final subdivision and/or land development applications submitted by 4:00pm on the last business day of the month will be reviewed by the Whitmarsh Township Planning Commission at a regular meeting two (2) months following the date of submission or other appropriate meeting date depending upon the results of Township reviews.

I hereby certify, as the undersigned applicant, that I am familiar with the provisions of: [1] Chapter 105, "Subdivision and Land Development", [2] Chapter 58, "Grading, Erosion Control, Stormwater Management and Best Management Practices", and [3] Chapter 55, "Tree Protection Standards" of the Code of the Township of Whitmarsh, as amended, and, to the best of my knowledge and belief, this application and the submitted plans conform to those provisions.

Date of Submission: 12/30/2021

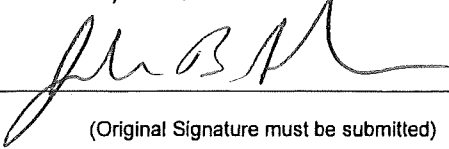
Signature: 
(Original Signature must be submitted)

Printed Name: John B. Anderson, agent for Applicant

I, (name) John B. Anderson (title) Principal of _____

(entity submitting application) Cornerstone Consulting do hereby affirm

that I am authorized by the applicant to affix my signature to this application.

Date: 12/30/2021

Signature: 
(Original Signature must be submitted)

WHITEMARSH TOWNSHIP
SUBDIVISION and/or LAND DEVELOPMENT
TIME WAIVER FORM

Date: 12/30/21

Granted to: Whitemarsh Township Board of Supervisors

Name of Subdivision and/or Land Development: West Ty

On or about 12/30/21, I/we submitted for official filing the above-reference application.

Notwithstanding any contrary provision of the Pennsylvania Municipalities Planning Code or the Code of the Township of Whitemarsh, this letter will serve as notice to Whitemarsh Township that the requirement that action be taken on this application within ninety (90) days is hereby waived, without limitation as to time. This waiver is granted to permit us to make revisions to the application during the application review process.

Further, with the understanding that this waiver is voluntarily given and will be relied upon by Whitemarsh Township, I/we will give Whitemarsh Township written notice (by certified mail or recognized overnight carrier) should we determine that limiting the time of the review process becomes necessary. Whitemarsh Township shall then have ninety (90) days from receipt of such written notice in which to act upon the application.

This waiver is not transferable or assignable by the Applicants and shall apply to any and all revised submissions made in relation to the above-referenced application.

I/we represent that I/we have been duly authorized to execute this waiver on behalf of the Applicant.

Date: 12/30/21

Signature:



(Original Signature must be submitted)

Printed Name:

Chuck Borkowski

Firm Name:

Borkowski Homes

Title:

President

(if applicable)

(if applicable)

POST CONSTRUCTION STORMWATER MANAGEMENT REPORT

FOR

Westy Project

BY: BORKOWSKI HOMES

927-31 SPRING MILL AVE
WHITEMARSH TOWNSHIP
MONTGOMERY COUNTY
PENNSYLVANIA

Project #: 21-0231

December 30, 2021

PREPARED BY



John B. Anderson, P.E.
License Number: PE055536

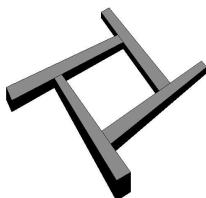

Cornerstone Consulting Engineers
& Architectural, Inc.

213 West Main Street, Lansdale, PA 19446

Phone (215) 362-2600

Fax (215) 362-8400

Table of Contents

Introduction.....	i
Existing Conditions.....	i
Proposed Conditions.....	i
Soil Conditions.....	ii

1.0 Design Criteria

- 1.1 Non-Structural Project Design
- 1.2 Stormwater Peak Rate Control
- 1.3 Water Quality Requirements
- 1.4 Infiltration Volume Requirements

2.0 Hydrograph Summaries

- 2.1 Hydraflow Rainfall Report
- 2.2 Hydrograph Return Period Recap
- 2.3 Hydrograph Summary Reports

3.0 Calculations

- 3.1 Infiltration Volume
- 3.2 Water Quality
- 3.3 C Calculations
- 3.4 Hydrographs
- 3.5 Stormwater Peak Rate Control

4.0 Appendices

- Appendix A Soil Report
- Appendix B Pre-Development Drainage Area Plan
- Appendix C Post-Development Drainage Area Plan

STORMWATER MANAGEMENT SUMMARY

PROPOSED MULTI-FAMILY, 20 UNIT RESIDENTIAL BLDG.
927-31 SPRING MILL ROAD
WHITEMARSH TOWNSHIP, MONTGOMERY COUNTY, PA

Introduction

The purpose of this report is to identify the existing and proposed conditions concerning the stormwater management issues for the subject development. Outlined in the body of this document is a stormwater management design that is intended to comply with the Township of Whitemarsh's Stormwater Management Ordinance. The area of total earth disturbance is 19,152 square feet (0.44 acres) and the total new or replacement impervious coverage is 10,538 sf (a total decrease of 4,629 sf impervious area).

Existing Conditions

The subject properties are located at 927 & 931 Spring Mill Ave, on the southwest corner of Lime Street, in Whitemarsh Township, Montgomery County, Pennsylvania. The site is bordered by residential properties. It consists of four (4) lots totaling approximately 0.401 acres within the C Residential zoning district, which is also covered by the Riverfront Development Overlay District, sub-district 2 (RDD-2). The existing lots contain a single family attached dwelling, one-story masonry building, concrete pads, and asphalt driveways from Spring Mill Ave. and Lime Street. The ground cover used in determining the existing conditions flow rates is based upon "meadow in good condition".

Currently, there is no stormwater management on site. Runoff from the site flows via sheet flow to neighboring properties mainly to the South, but some flows north into the inlets along Spring Mill Ave. The site is located within the Schuylkill River watershed.

Proposed Conditions

The lot is proposed to be consolidated into one (1) lot. The proposed grading of the property is mostly held consistent to pre-development conditions. The existing house and adjoining concrete walkway will remain. The proposed residential building will contain a sub level parking accessible from Lime Street. This parking will be graded to move stormwater to a curbed inlet along the southern edge of the property. Parking surfaces will be composed of permeable pavers to permit infiltration of stormwater into the underground basin.

To manage the post development stormwater, an underground stone infiltration bed is proposed under the permeable pavers. Detailing and calculations of the infiltration bed design is contained within the body of this report. The captured water from the building's roof flows through an inlet then disperse into a bed of stone. The parking area flow will be conveyed overland to an inlet into the proposed underground infiltration basin. The outflow pipe is set at an elevation to capture the required water quality volume and provides for rate control. The discharge pipe then ties into the existing storm pipe in Lime Street.

Soil Conditions

The site is entirely made up of urban land. This is based on the USDA-NRCS Soils Survey of Montgomery County, from the USDA web soil survey.

Soil	HSG	Slope	Depth to Seasonal High Water Table	Depth to Bedrock	Hazard of Erosion	Permeability
UgB	C	0-8%	>80 in	>80 in	Low	n/a

The following resolutions are proposed for soil limitations that may be encountered: For construction within areas where ground water is encountered, drainage channels or underdrains should be provided. Fill for the area should be obtained from other site areas and an appropriate seed mixture should be planted. For construction within areas where bedrock is encountered, a revised design should be considered first to relocate the construction and if relocation is not possible, ripable rock shall be excavated. The site has been designed to avoid soil limitations when possible.

1.0 DESIGN CRITERIA

1.1 Non-Structural Project Design

The layout for the site, including the proposed grading, was designed to keep the limit of disturbance at a minimum. Disturbed lawn areas will be restored to their existing pervious condition. The site proposes to decrease the impervious coverage of the lot.

1.2 Stormwater Peak Rate Control; Ordinance Sec. C.(1)

All earth disturbance activities shall limit the rate of stormwater runoff so that no greater runoff is permitted from any point on the site than that of the site at its maximum development potential in its natural condition (meadow) for the same frequency storm, except where deemed necessary by the Township engineer. The site is located within the Schuylkill River Watershed.

1.3 Water Quality Requirements; Ordinance Sec. F(3)(c)

In order to protect and maintain Water Quality, additional stormwater runoff created by the development project must be captured, stored and treated. In addition, post-construction stormwater infiltration of runoff must replicate pre-construction infiltration of runoff to the maximum extent possible.

1.4 Infiltration Volume Requirements; Ordinance Sec. F(3)(d)

Post construction stormwater infiltration of runoff shall replicate pre-construction infiltration of runoff to the maximum extent possible.

2.0 HYDROGRAPH SUMMARIES

Hydrograph Return Period Recap

Hydratlow Hydrographs Extension for AutoCAD® Civil 3D® 2018 by Autodesk, Inc. v2018.3

Hyd. No.	Hydrograph type (origin)	Inflow hyd(s)	Peak Outflow (cfs)								Hydrograph Description
			1-yr	2-yr	3-yr	5-yr	10-yr	25-yr	50-yr	100-yr	
1	Dekalb	-----	0.492	0.566	-----	0.664	0.741	0.825	0.924	1.008	PRE
2	Dekalb	-----	1.063	1.222	-----	1.433	1.599	1.782	1.994	2.177	Basin #1
3	Reservoir	2	0.000	0.000	-----	0.000	0.000	0.000	0.070	0.227	Basin #1 Outflow
4	Dekalb	-----	0.421	0.484	-----	0.568	0.634	0.706	0.790	0.862	Bypass
5	Combine	3, 4	0.421	0.484	-----	0.568	0.634	0.706	0.790	0.862	TOTAL POST

Hydrograph Summary Report

Hydraflow Hydrographs Extension for AutoCAD® Civil 3D® 2018 by Autodesk, Inc. v2018.3

Hyd. No.	Hydrograph type (origin)	Peak flow (cfs)	Time interval (min)	Time to Peak (min)	Hyd. volume (cuft)	Inflow hyd(s)	Maximum elevation (ft)	Total strge used (cuft)	Hydrograph Description	
1	Dekalb	0.492	1	25	441	-----	-----	-----	PRE	
2	Dekalb	1.063	1	25	953	-----	-----	-----	Basin #1	
3	Reservoir	0.000	1	n/a	0	2	58.50	953	Basin #1 Outflow	
4	Dekalb	0.421	1	25	378	-----	-----	-----	Bypass	
5	Combine	0.421	1	25	378	3, 4	-----	-----	TOTAL POST	
21-0231_hydrographs.gpw					Return Period: 1 Year			Thursday, 12 / 30 / 2021		

Hydrograph Summary Report

Hydraflow Hydrographs Extension for AutoCAD® Civil 3D® 2018 by Autodesk, Inc. v2018.3

Hyd. No.	Hydrograph type (origin)	Peak flow (cfs)	Time interval (min)	Time to Peak (min)	Hyd. volume (cuft)	Inflow hyd(s)	Maximum elevation (ft)	Total strge used (cuft)	Hydrograph Description	
1	Dekalb	0.566	1	25	508	-----	-----	-----	PRE	
2	Dekalb	1.222	1	25	1,096	-----	-----	-----	Basin #1	
3	Reservoir	0.000	1	n/a	0	2	58.69	1,096	Basin #1 Outflow	
4	Dekalb	0.484	1	25	434	-----	-----	-----	Bypass	
5	Combine	0.484	1	25	434	3, 4	-----	-----	TOTAL POST	
21-0231_hydrographs.gpw					Return Period: 2 Year			Thursday, 12 / 30 / 2021		

Hydrograph Summary Report

Hydraflow Hydrographs Extension for AutoCAD® Civil 3D® 2018 by Autodesk, Inc. v2018.3

Hyd. No.	Hydrograph type (origin)	Peak flow (cfs)	Time interval (min)	Time to Peak (min)	Hyd. volume (cuft)	Inflow hyd(s)	Maximum elevation (ft)	Total strge used (cuft)	Hydrograph Description	
1	Dekalb	0.664	1	25	595	-----	-----	-----	PRE	
2	Dekalb	1.433	1	25	1,285	-----	-----	-----	Basin #1	
3	Reservoir	0.000	1	n/a	0	2	58.94	1,285	Basin #1 Outflow	
4	Dekalb	0.568	1	25	509	-----	-----	-----	Bypass	
5	Combine	0.568	1	25	509	3, 4	-----	-----	TOTAL POST	
21-0231_hydrographs.gpw					Return Period: 5 Year			Thursday, 12 / 30 / 2021		

Hydrograph Summary Report

Hydraflow Hydrographs Extension for AutoCAD® Civil 3D® 2018 by Autodesk, Inc. v2018.3

Hyd. No.	Hydrograph type (origin)	Peak flow (cfs)	Time interval (min)	Time to Peak (min)	Hyd. volume (cuft)	Inflow hyd(s)	Maximum elevation (ft)	Total strge used (cuft)	Hydrograph Description	
1	Dekalb	0.741	1	25	664	-----	-----	-----	PRE	
2	Dekalb	1.599	1	25	1,434	-----	-----	-----	Basin #1	
3	Reservoir	0.000	1	n/a	0	2	59.14	1,434	Basin #1 Outflow	
4	Dekalb	0.634	1	25	568	-----	-----	-----	Bypass	
5	Combine	0.634	1	25	568	3, 4	-----	-----	TOTAL POST	
21-0231_hydrographs.gpw					Return Period: 10 Year			Thursday, 12 / 30 / 2021		

Hydrograph Summary Report

Hydraflow Hydrographs Extension for AutoCAD® Civil 3D® 2018 by Autodesk, Inc. v2018.3

Hyd. No.	Hydrograph type (origin)	Peak flow (cfs)	Time interval (min)	Time to Peak (min)	Hyd. volume (cuft)	Inflow hyd(s)	Maximum elevation (ft)	Total strge used (cuft)	Hydrograph Description	
1	Dekalb	0.825	1	25	740	-----	-----	-----	PRE	
2	Dekalb	1.782	1	25	1,598	-----	-----	-----	Basin #1	
3	Reservoir	0.000	1	n/a	0	2	59.36	1,598	Basin #1 Outflow	
4	Dekalb	0.706	1	25	633	-----	-----	-----	Bypass	
5	Combine	0.706	1	25	633	3, 4	-----	-----	TOTAL POST	
21-0231_hydrographs.gpw					Return Period: 25 Year			Thursday, 12 / 30 / 2021		

Hydrograph Summary Report

Hydraflow Hydrographs Extension for AutoCAD® Civil 3D® 2018 by Autodesk, Inc. v2018.3

Hyd. No.	Hydrograph type (origin)	Peak flow (cfs)	Time interval (min)	Time to Peak (min)	Hyd. volume (cuft)	Inflow hyd(s)	Maximum elevation (ft)	Total strge used (cuft)	Hydrograph Description	
1	Dekalb	0.924	1	25	828	-----	-----	-----	PRE	
2	Dekalb	1.994	1	25	1,789	-----	-----	-----	Basin #1	
3	Reservoir	0.070	1	49	85	2	59.59	1,767	Basin #1 Outflow	
4	Dekalb	0.790	1	25	709	-----	-----	-----	Bypass	
5	Combine	0.790	1	25	794	3, 4	-----	-----	TOTAL POST	
21-0231_hydrographs.gpw					Return Period: 50 Year			Thursday, 12 / 30 / 2021		

Hydrograph Summary Report

Hydraflow Hydrographs Extension for AutoCAD® Civil 3D® 2018 by Autodesk, Inc. v2018.3

Hyd. No.	Hydrograph type (origin)	Peak flow (cfs)	Time interval (min)	Time to Peak (min)	Hyd. volume (cuft)	Inflow hyd(s)	Maximum elevation (ft)	Total strge used (cuft)	Hydrograph Description	
1	Dekalb	1.008	1	25	904	-----	-----	-----	PRE	
2	Dekalb	2.177	1	25	1,952	-----	-----	-----	Basin #1	
3	Reservoir	0.227	1	46	249	2	59.70	1,849	Basin #1 Outflow	
4	Dekalb	0.862	1	25	774	-----	-----	-----	Bypass	
5	Combine	0.862	1	25	1,023	3, 4	-----	-----	TOTAL POST	
21-0231_hydrographs.gpw					Return Period: 100 Year			Thursday, 12 / 30 / 2021		

3.0 CALCULATIONS

3.1 Infiltration Calculations:

$Re_v = [(S)(R_v)(A)]/12$, where:

Re_v = Recharge volume (acre-feet)

S = Soil specific recharge factor (inches)

A = Site area contributing to the recharge facility (acres)

R_v = Volumetric runoff coefficient,

$R_v = 0.05 + 0.009(I)$, where:

I = percent impervious cover

(impervious area / total project area) x 100%

and 'S' shall be obtained based upon hydrologic soil groups, i.g.

HSG-C = 0.13

$$\begin{aligned} Re_v &= [(0.13)((0.05 + 0.009((0.35/0.44) \times 100))(0.44)]/12 \\ &= [(0.13)(0.7659)(0.44)]/12 \\ &= 0.04381/12 \\ &= 0.00365 \text{ ac-ft} \\ &\times 43560 = \mathbf{158.99 \text{ cf} = \text{REQUIRED}} \end{aligned}$$

PROVIDED = 1,702 cf

3.2 Water Quality Calculations:

Area of proposed building and parking lot (19,152sf; 0.44ac)

$WQ_v = [(0.17)(R_v)(A)]$, where:

A = Project Area in acres

R_v = Volumetric Runoff Coefficient,

$R_v = 0.05 + 0.009(I)$, where I is the percent impervious cover

(impervious area / total project area) x 100%

$$\begin{aligned} WQ_v &= [(0.17)((0.05 + 0.009((0.35/0.44) \times 100))(0.44)] \\ &= [(0.17)(0.7159)(0.44)] \\ &= 0.0535 \text{ ac-ft} \\ &\times 43560 = \mathbf{2332.61 \text{ cf} = \text{REQUIRED}} \end{aligned}$$

PROVIDED = 2,827 cf

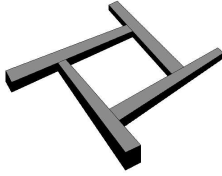

Cornerstone Consulting Engineers & Architectural, Inc.

213 West Main Street, Lansdale, PA 19446

Phone (215)362-2600

Fax (215)362-8400

Runoff Coefficient

Project: Lime St

Location: Whitmarsh Township

Development Type: Pre-Development Post-Development

Pre-Development

Runoff Coefficient (C)

Soil Name	Cover Description	C	Area (Acres)	Product of C * Area
UgB	Meadow	0.28	0.440	0.123
Totals =			0.440	0.123

$C \text{ (Weighted)} = \frac{\text{Total Product}}{\text{Total Area}} = 0.280$

Use C =

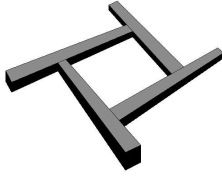

Cornerstone Consulting Engineers & Architectural, Inc.

213 West Main Street, Lansdale, PA 19446

Phone (215)362-2600

Fax (215)362-8400

Runoff Coefficient

Project: Lime St

Location: Whitmarsh Township

Developemnt Type: Pre-Development Post-Development

Basin #1

Runoff Coefficient (C)

Soil Name	Cover Description	C	Area (Acres)	Product of C * Area
UgB	Building	0.95	0.210	0.200
UgB	Permeable Pavers	0.95	0.070	0.067
Totals =			0.280	0.266

$C \text{ (Weighted)} = \frac{\text{Total Product}}{\text{Total Area}} = 0.950$

Use C = 0.95

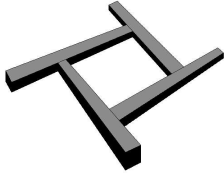

Cornerstone Consulting Engineers & Architectural, Inc.

213 West Main Street, Lansdale, PA 19446

Phone (215)362-2600

Fax (215)362-8400

Runoff Coefficient

Project: Lime St

Location: Whitemarsh Township

Development Type: Pre-Development Post-Development

Bypass

Runoff Coefficient (C)

Soil Name	Cover Description	C	Area (Acres)	Product of C * Area
UgB	Landscape Area	0.32	0.090	0.029
UgB	Concrete Sidewalks	0.95	0.080	0.076
Totals =			0.170	0.105

$C \text{ (Weighted)} = \frac{\text{Total Product}}{\text{Total Area}} = 0.616$

Use C = 0.62

Hydrograph Report

Hyd. No. 1

PRE

Hydrograph type	= Dekalb	Peak discharge	= 0.492 cfs
Storm frequency	= 1 yrs	Time to peak	= 25 min
Time interval	= 1 min	Hyd. volume	= 441 cuft
Drainage area	= 0.440 ac	Runoff coeff.	= 0.28*
Intensity	= 3.995 in/hr	Tc by User	= 5.00 min
IDF Curve	= Region 5.IDF	Asc/Rec limb fact	= n/a

* Composite (Area/C) = $[(0.440 \times 0.35)] / 0.440$

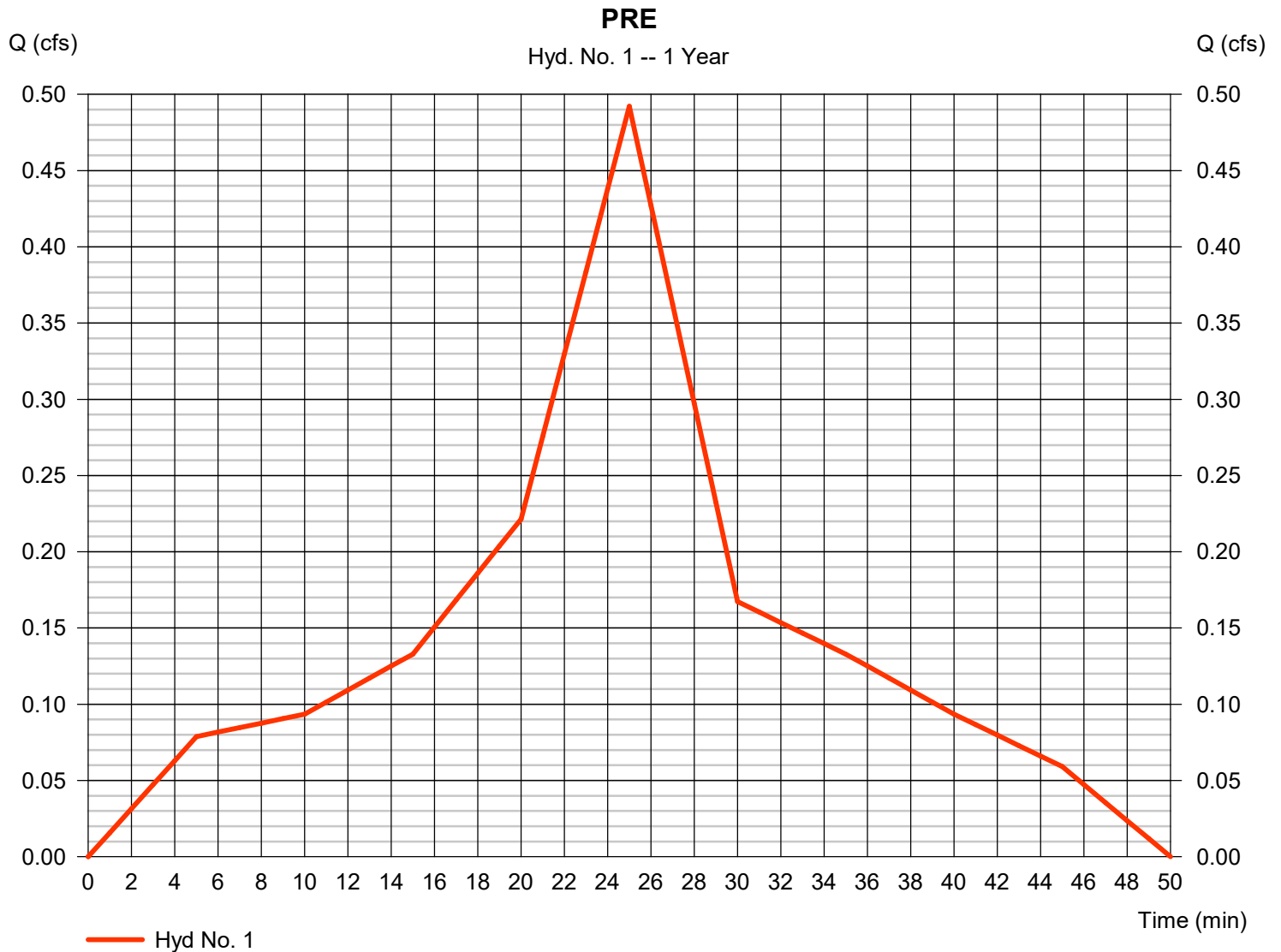

Hydrograph Report

Hyd. No. 2

Basin #1

Hydrograph type	= Dekalb	Peak discharge	= 1.063 cfs
Storm frequency	= 1 yrs	Time to peak	= 25 min
Time interval	= 1 min	Hyd. volume	= 953 cuft
Drainage area	= 0.280 ac	Runoff coeff.	= 0.95*
Intensity	= 3.995 in/hr	Tc by User	= 5.00 min
IDF Curve	= Region 5.IDF	Asc/Rec limb fact	= n/a

* Composite (Area/C) = $[(0.210 \times 0.95) + (0.070 \times 0.15)] / 0.280$

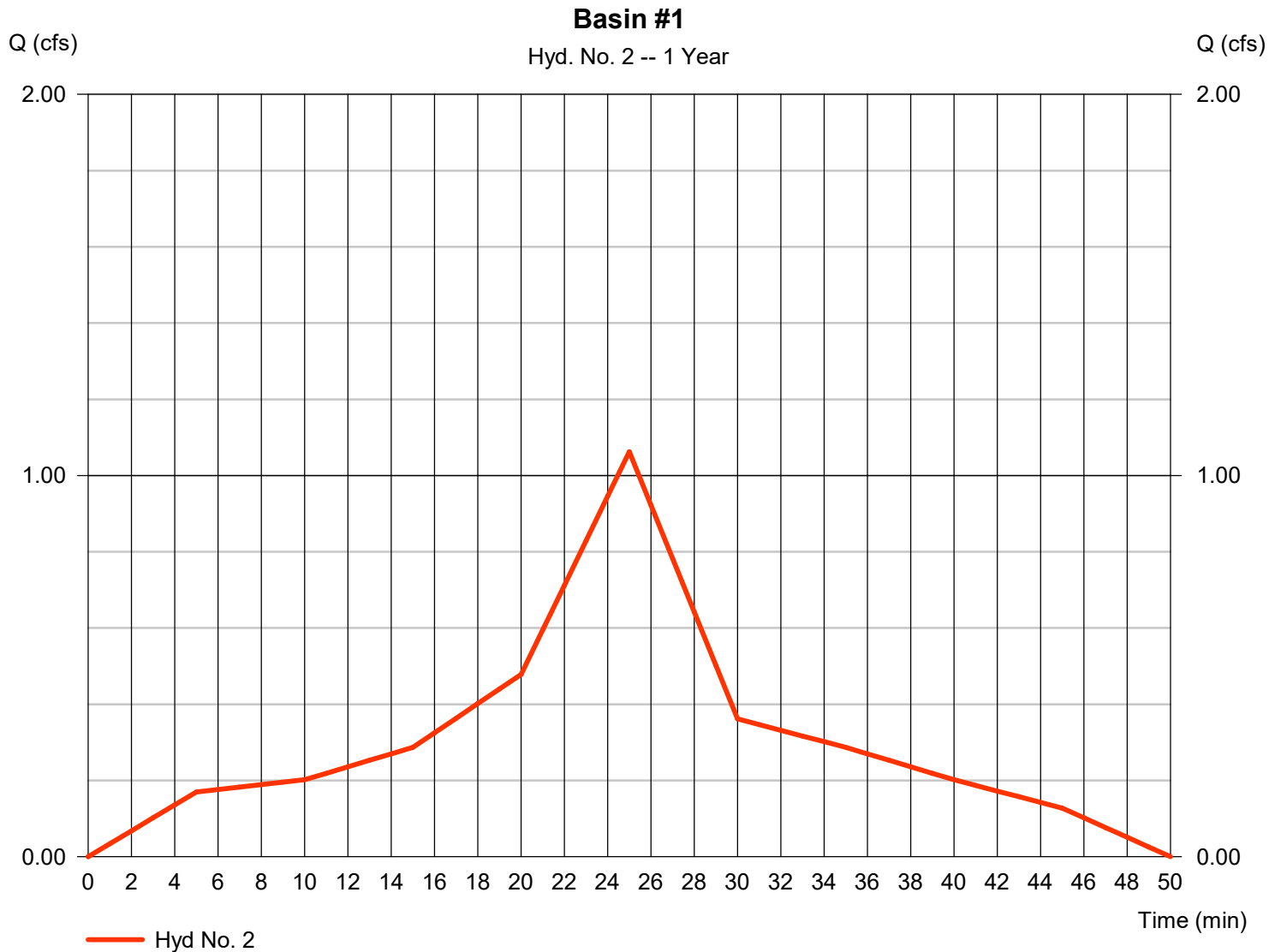

Hydrograph Report

Hyd. No. 3

Basin #1 Outflow

Hydrograph type	= Reservoir	Peak discharge	= 0.000 cfs
Storm frequency	= 1 yrs	Time to peak	= n/a
Time interval	= 1 min	Hyd. volume	= 0 cuft
Inflow hyd. No.	= 2 - Basin #1	Max. Elevation	= 58.50 ft
Reservoir name	= Basin #1	Max. Storage	= 953 cuft

Storage Indication method used.

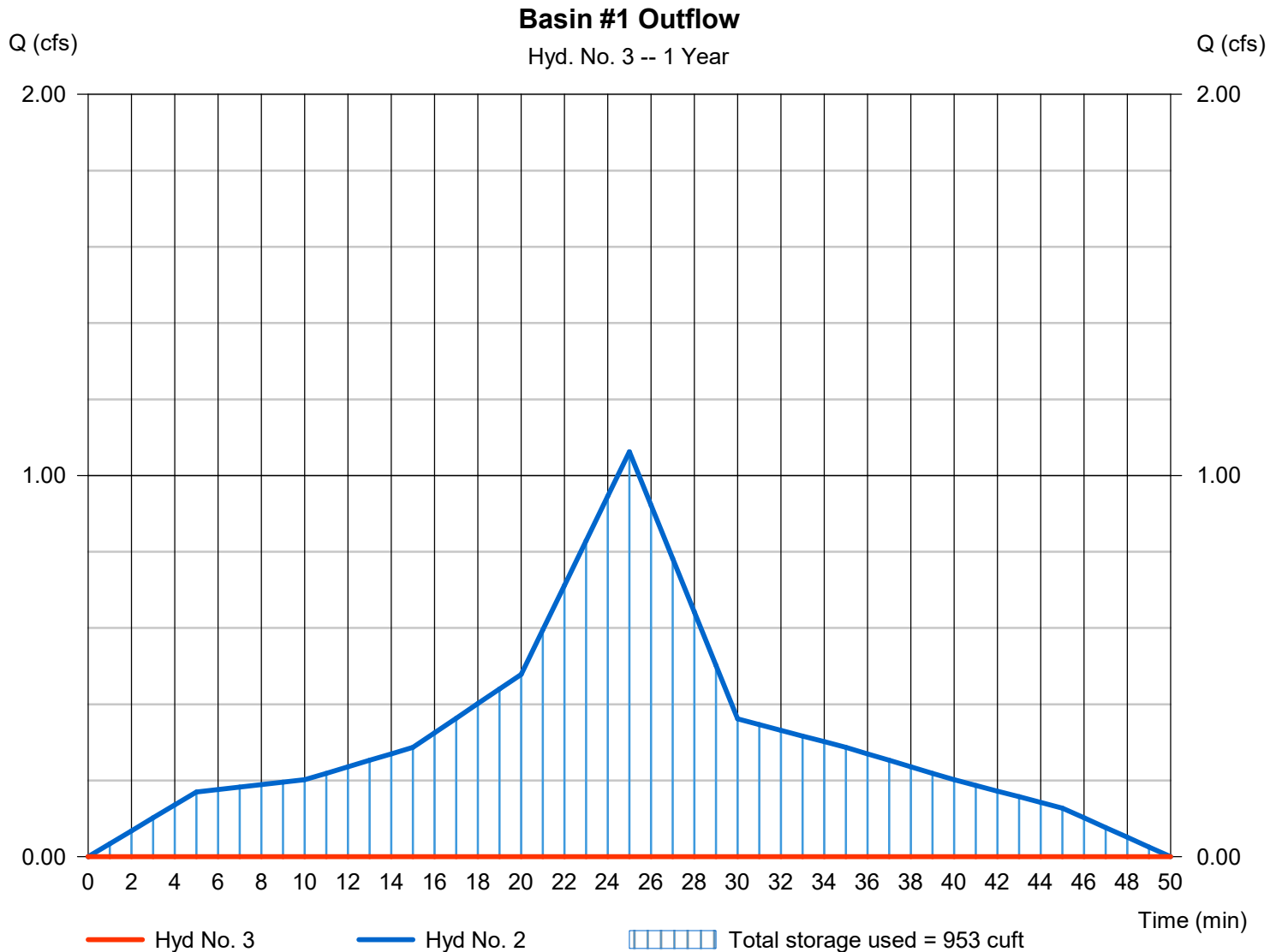

Hydrograph Report

Hyd. No. 4

Bypass

Hydrograph type	= Dekalb	Peak discharge	= 0.421 cfs
Storm frequency	= 1 yrs	Time to peak	= 25 min
Time interval	= 1 min	Hyd. volume	= 378 cuft
Drainage area	= 0.170 ac	Runoff coeff.	= 0.62*
Intensity	= 3.995 in/hr	Tc by User	= 5.00 min
IDF Curve	= Region 5.IDF	Asc/Rec limb fact	= n/a

* Composite (Area/C) = $[(0.090 \times 0.30) + (0.080 \times 0.95)] / 0.170$

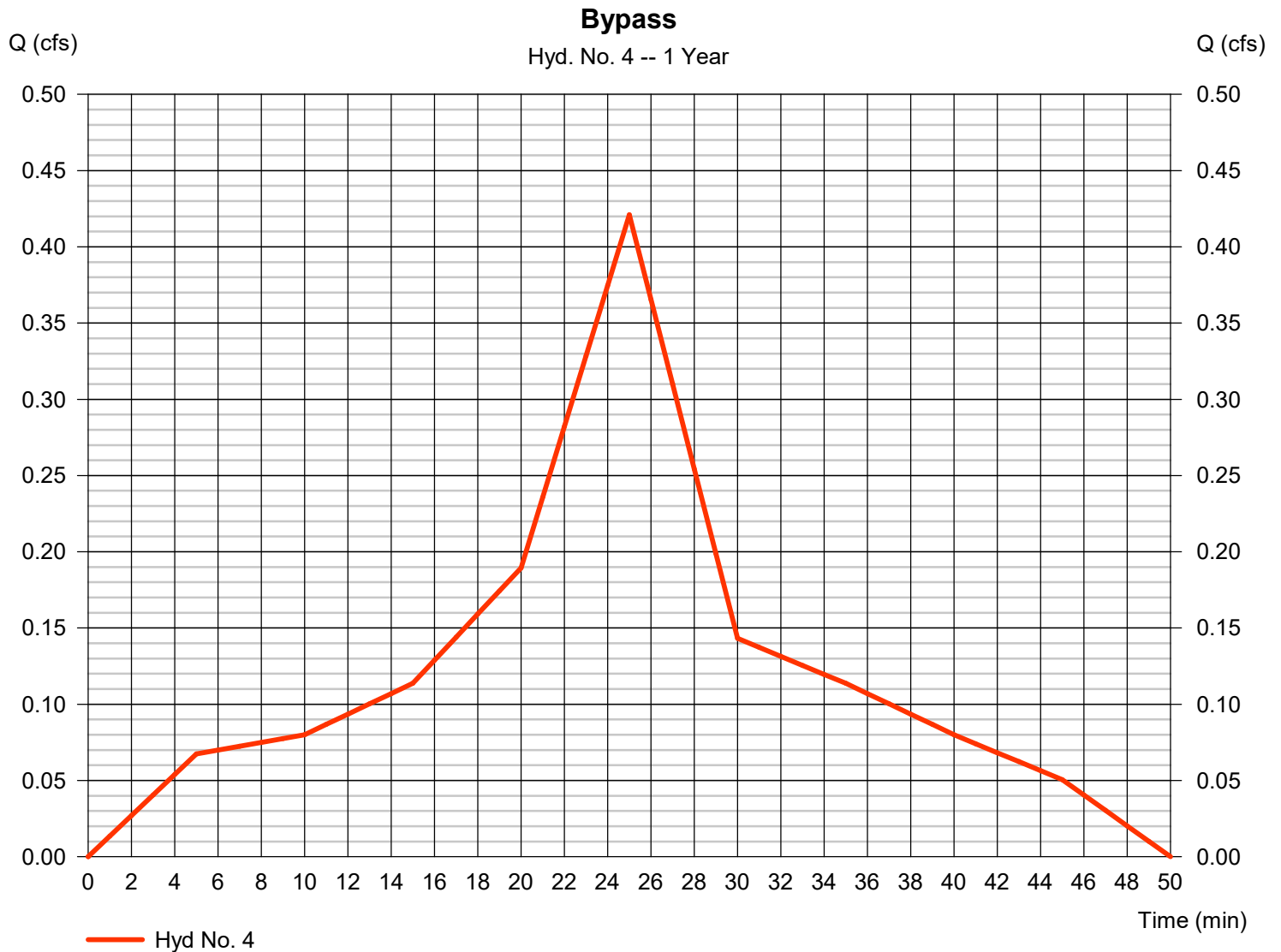

Hydrograph Report

Hyd. No. 5

TOTAL POST

Hydrograph type = Combine
Storm frequency = 1 yrs
Time interval = 1 min
Inflow hyds. = 3, 4

Peak discharge = 0.421 cfs
Time to peak = 25 min
Hyd. volume = 378 cuft
Contrib. drain. area = 0.170 ac

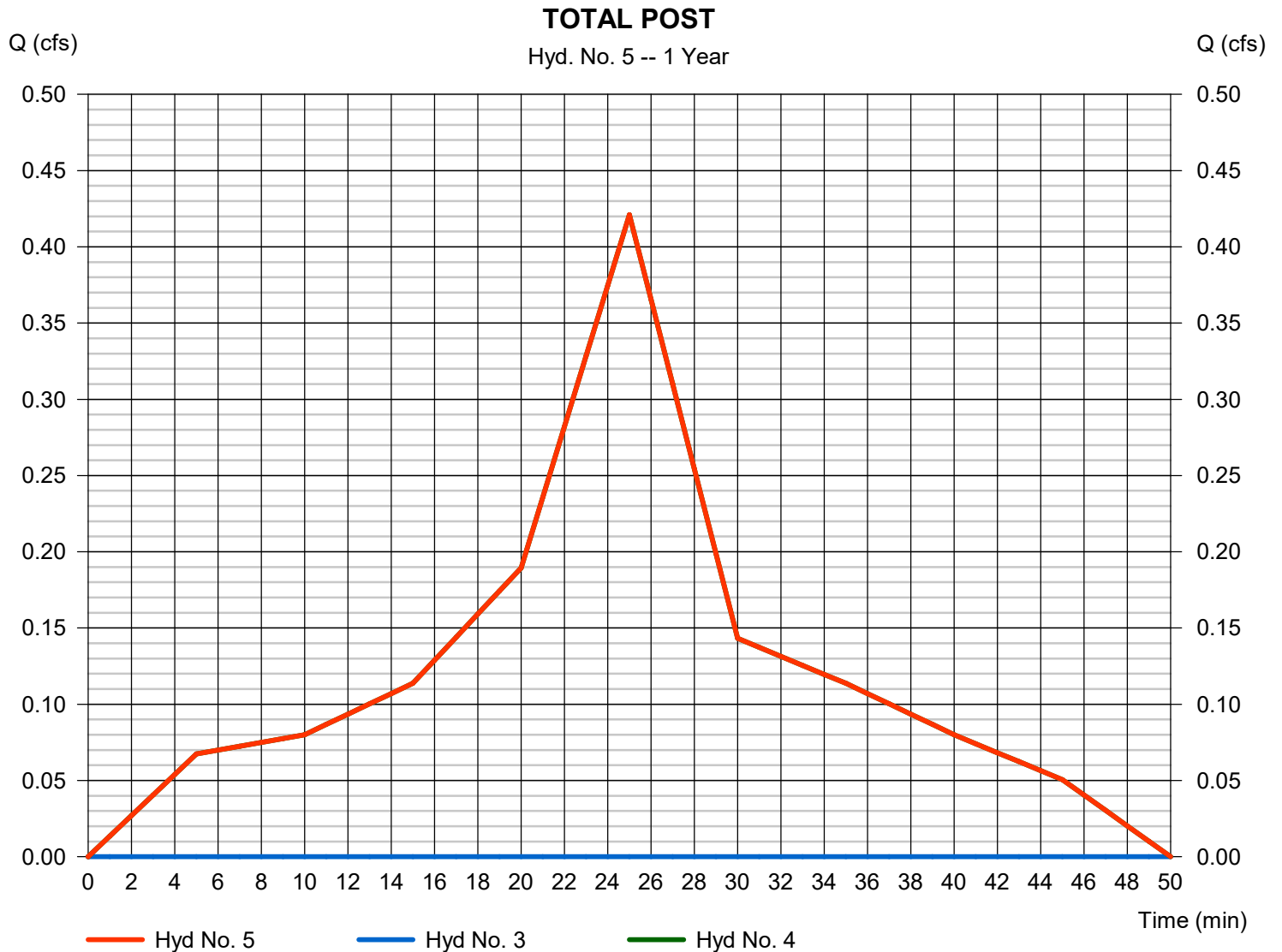

Hydrograph Report

Hyd. No. 1

PRE

Hydrograph type	= Dekalb	Peak discharge	= 0.566 cfs
Storm frequency	= 2 yrs	Time to peak	= 25 min
Time interval	= 1 min	Hyd. volume	= 508 cuft
Drainage area	= 0.440 ac	Runoff coeff.	= 0.28*
Intensity	= 4.594 in/hr	Tc by User	= 5.00 min
IDF Curve	= Region 5.IDF	Asc/Rec limb fact	= n/a

* Composite (Area/C) = $[(0.440 \times 0.35)] / 0.440$

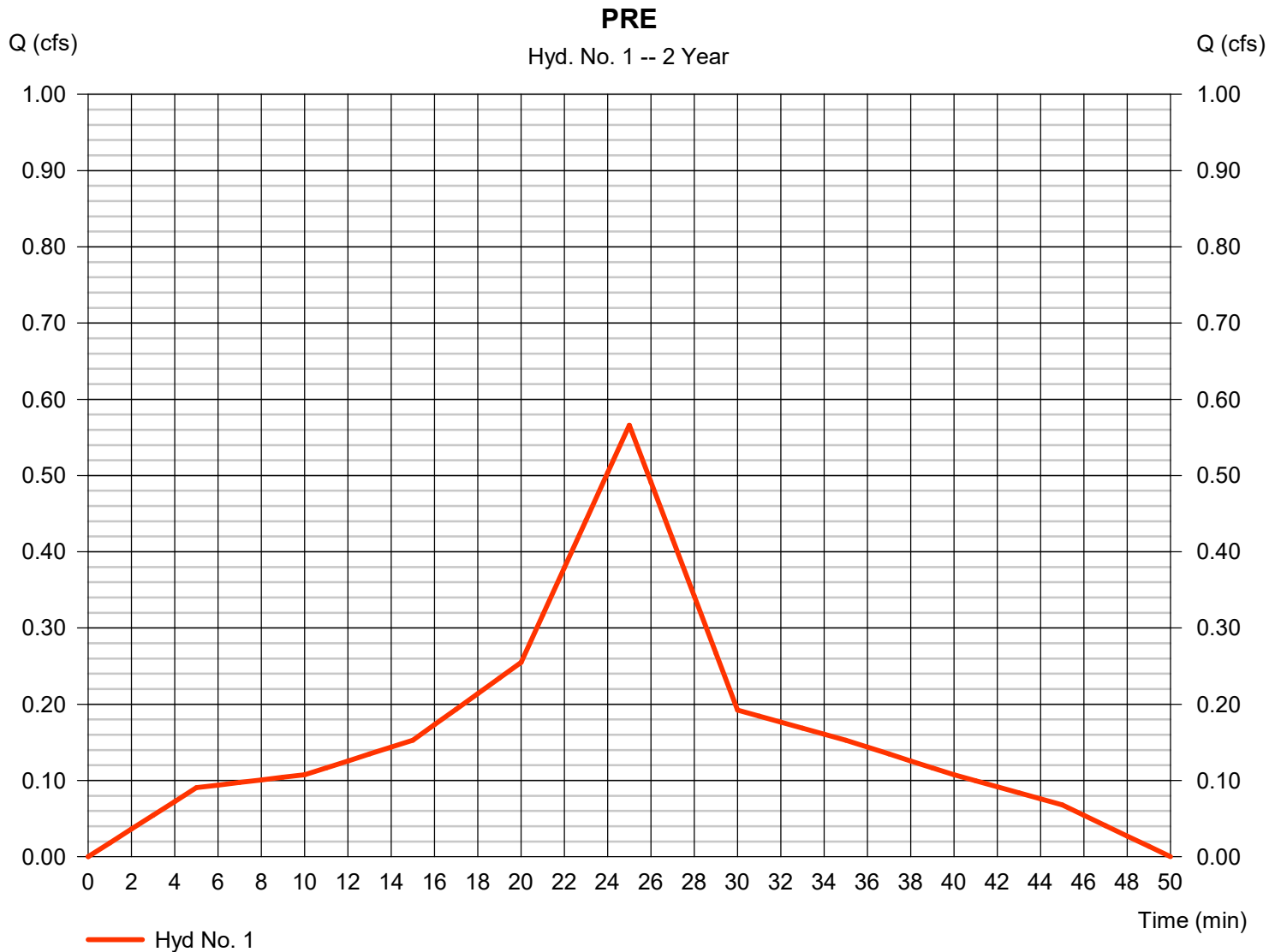

Hydrograph Report

Hyd. No. 2

Basin #1

Hydrograph type	= Dekalb	Peak discharge	= 1.222 cfs
Storm frequency	= 2 yrs	Time to peak	= 25 min
Time interval	= 1 min	Hyd. volume	= 1,096 cuft
Drainage area	= 0.280 ac	Runoff coeff.	= 0.95*
Intensity	= 4.594 in/hr	Tc by User	= 5.00 min
IDF Curve	= Region 5.IDF	Asc/Rec limb fact	= n/a

* Composite (Area/C) = $[(0.210 \times 0.95) + (0.070 \times 0.15)] / 0.280$

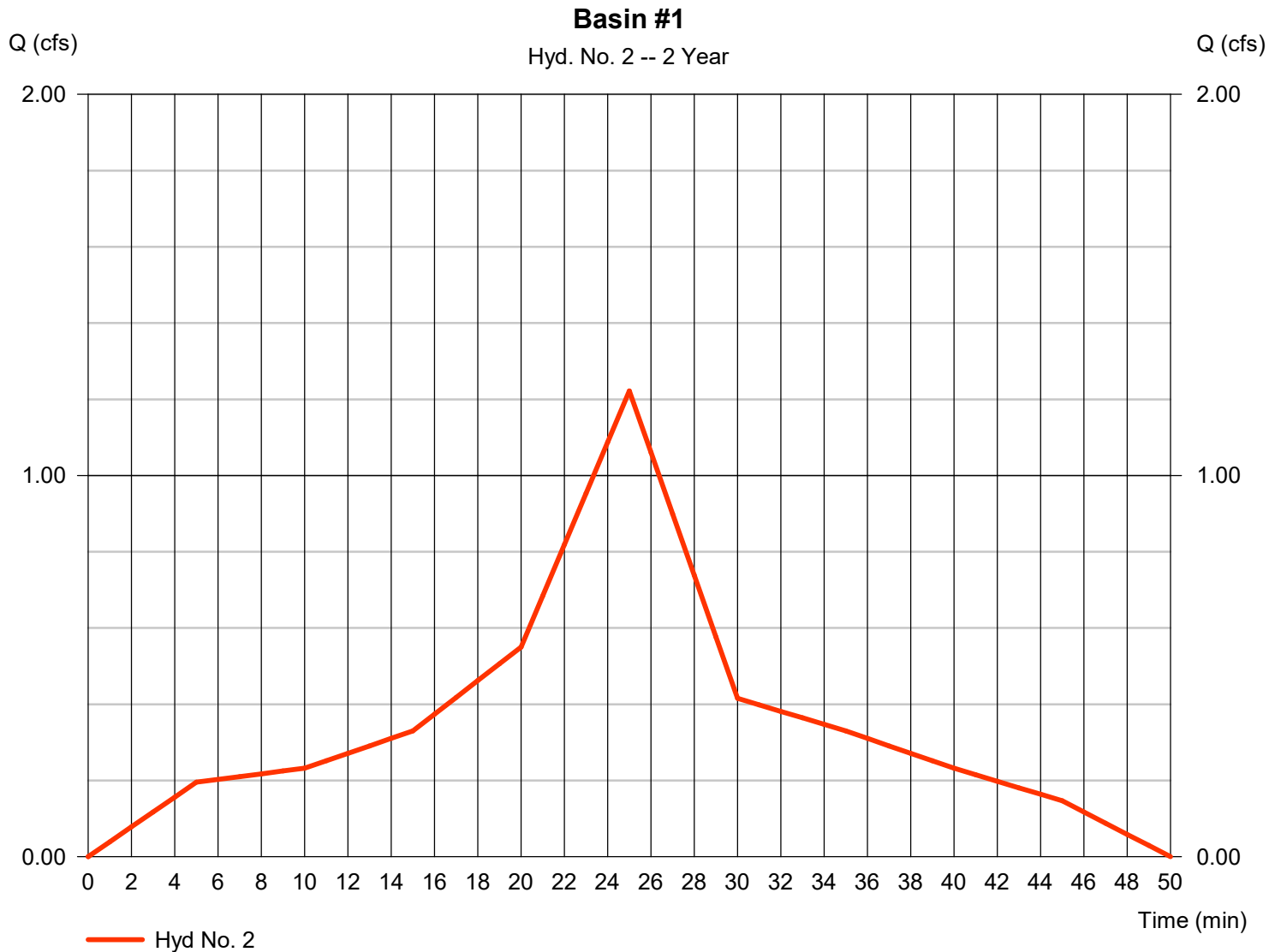

Hydrograph Report

Hyd. No. 3

Basin #1 Outflow

Hydrograph type	= Reservoir	Peak discharge	= 0.000 cfs
Storm frequency	= 2 yrs	Time to peak	= n/a
Time interval	= 1 min	Hyd. volume	= 0 cuft
Inflow hyd. No.	= 2 - Basin #1	Max. Elevation	= 58.69 ft
Reservoir name	= Basin #1	Max. Storage	= 1,096 cuft

Storage Indication method used.

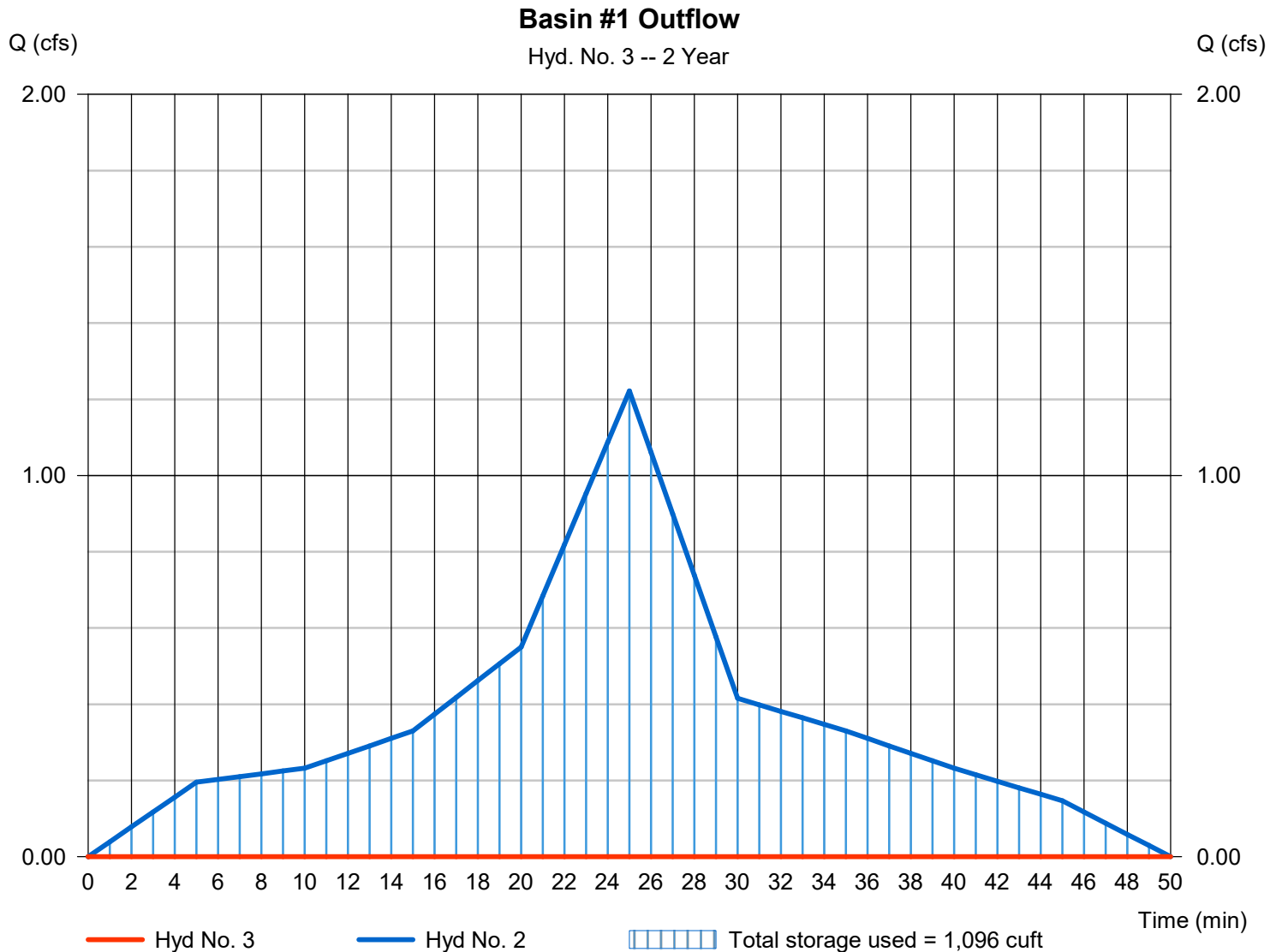

Hydrograph Report

Hyd. No. 4

Bypass

Hydrograph type	= Dekalb	Peak discharge	= 0.484 cfs
Storm frequency	= 2 yrs	Time to peak	= 25 min
Time interval	= 1 min	Hyd. volume	= 434 cuft
Drainage area	= 0.170 ac	Runoff coeff.	= 0.62*
Intensity	= 4.594 in/hr	Tc by User	= 5.00 min
IDF Curve	= Region 5.IDF	Asc/Rec limb fact	= n/a

* Composite (Area/C) = $[(0.090 \times 0.30) + (0.080 \times 0.95)] / 0.170$

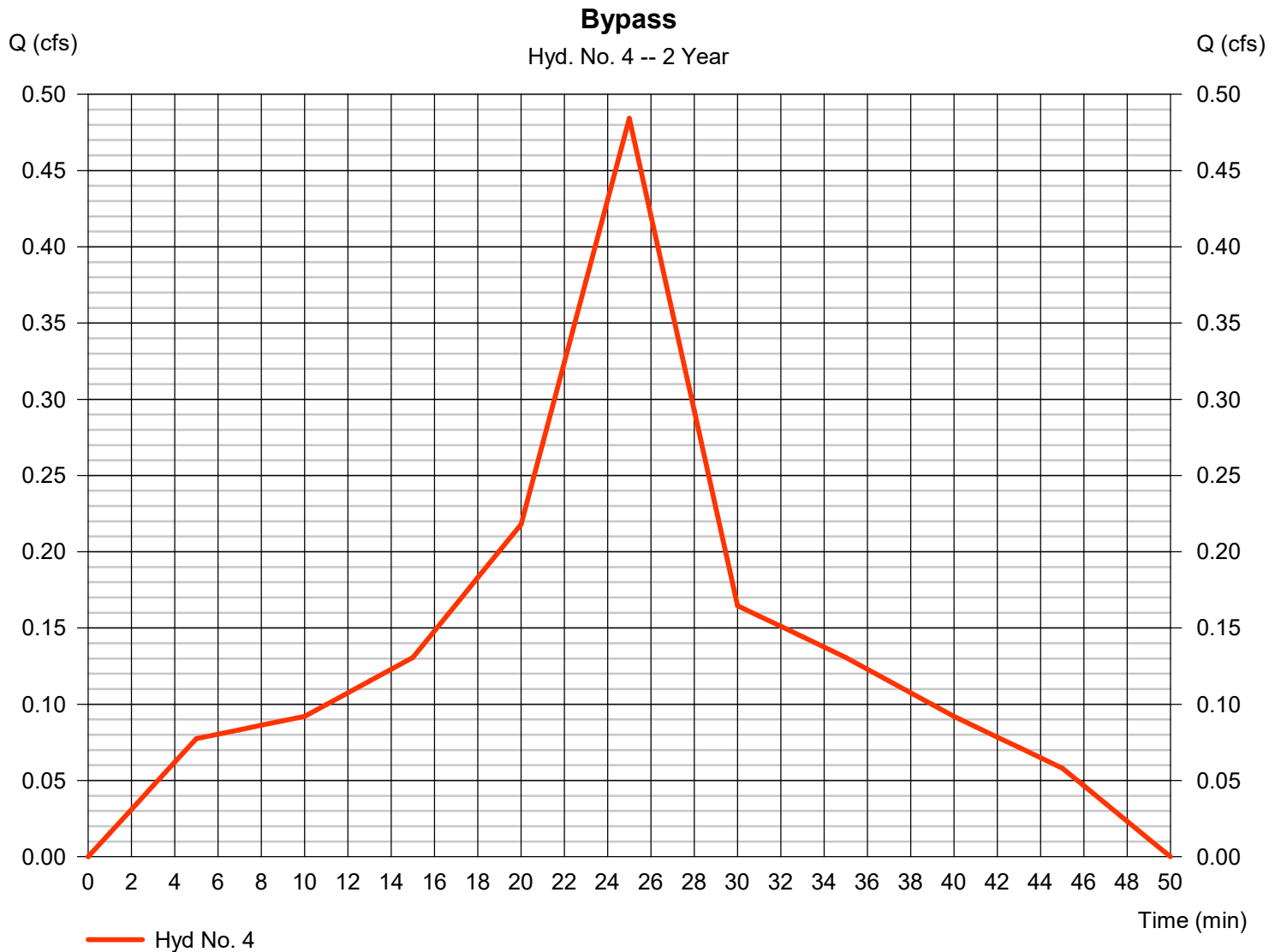

Hydrograph Report

Hyd. No. 5

TOTAL POST

Hydrograph type = Combine
Storm frequency = 2 yrs
Time interval = 1 min
Inflow hyds. = 3, 4

Peak discharge = 0.484 cfs
Time to peak = 25 min
Hyd. volume = 434 cuft
Contrib. drain. area = 0.170 ac

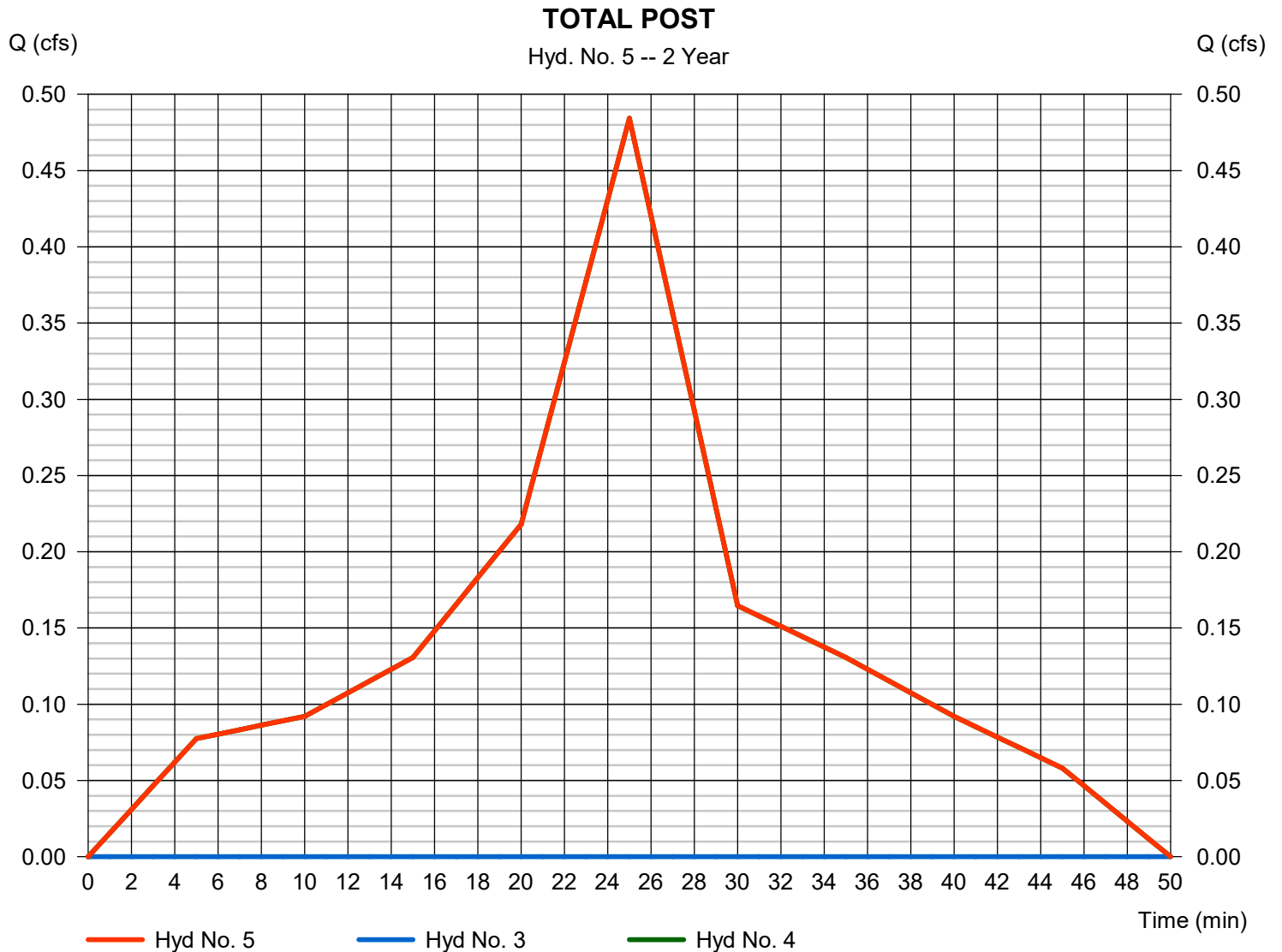

Hydrograph Report

Hyd. No. 1

PRE

Hydrograph type	= Dekalb	Peak discharge	= 0.664 cfs
Storm frequency	= 5 yrs	Time to peak	= 25 min
Time interval	= 1 min	Hyd. volume	= 595 cuft
Drainage area	= 0.440 ac	Runoff coeff.	= 0.28*
Intensity	= 5.387 in/hr	Tc by User	= 5.00 min
IDF Curve	= Region 5.IDF	Asc/Rec limb fact	= n/a

* Composite (Area/C) = $[(0.440 \times 0.35)] / 0.440$

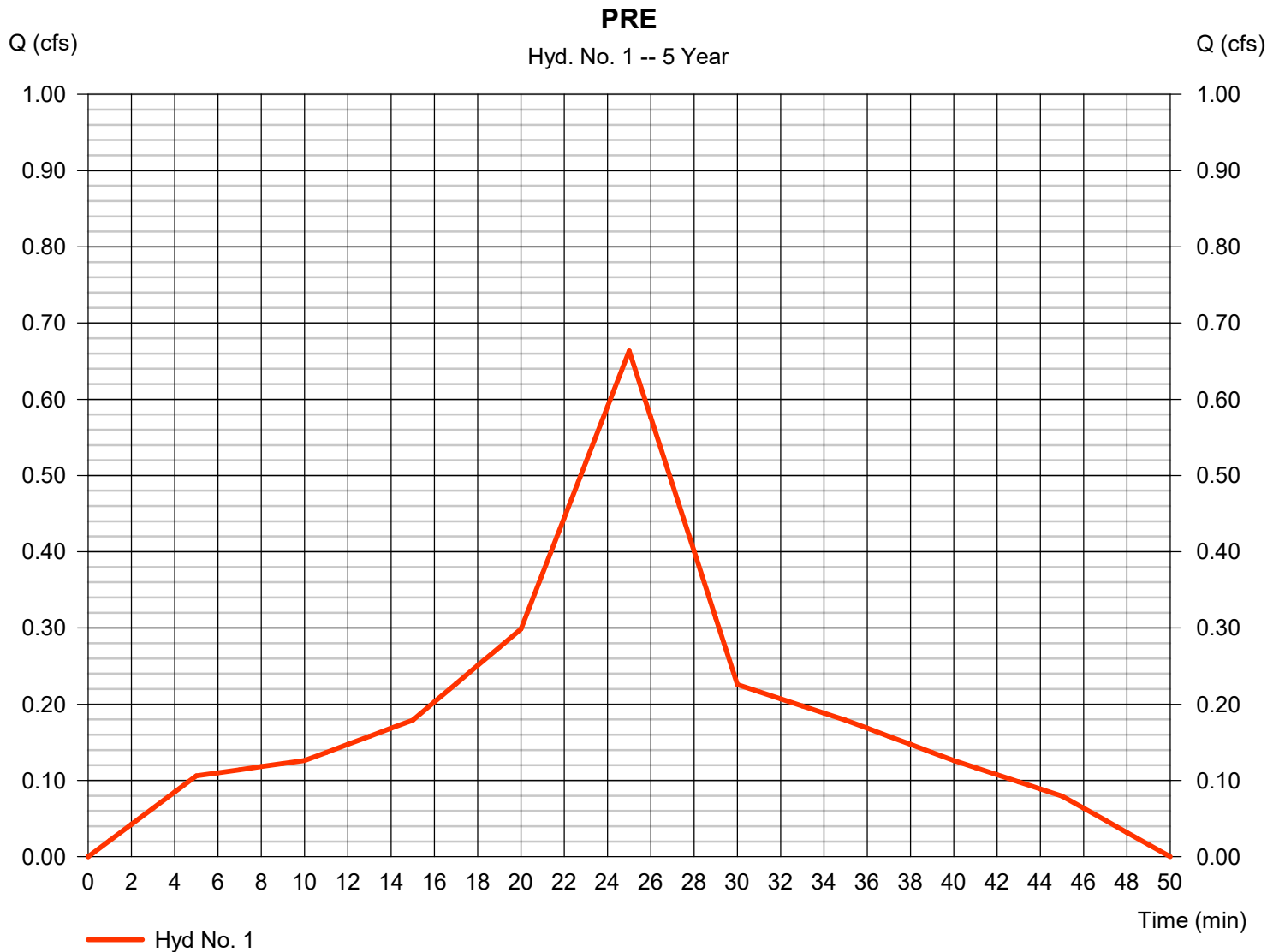

Hydrograph Report

Hyd. No. 2

Basin #1

Hydrograph type	= Dekalb	Peak discharge	= 1.433 cfs
Storm frequency	= 5 yrs	Time to peak	= 25 min
Time interval	= 1 min	Hyd. volume	= 1,285 cuft
Drainage area	= 0.280 ac	Runoff coeff.	= 0.95*
Intensity	= 5.387 in/hr	Tc by User	= 5.00 min
IDF Curve	= Region 5.IDF	Asc/Rec limb fact	= n/a

* Composite (Area/C) = $[(0.210 \times 0.95) + (0.070 \times 0.15)] / 0.280$

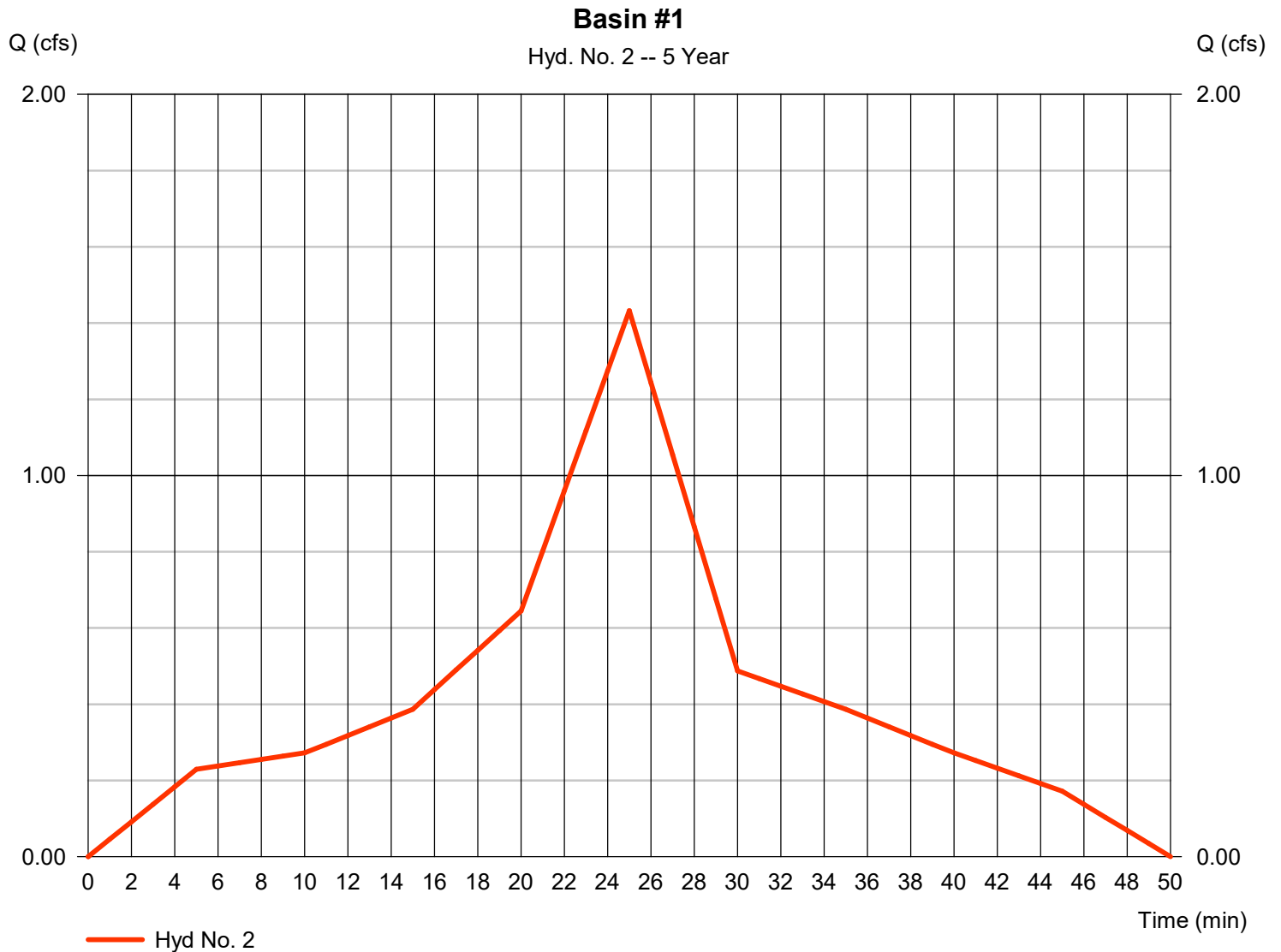

Hydrograph Report

Hyd. No. 3

Basin #1 Outflow

Hydrograph type	= Reservoir	Peak discharge	= 0.000 cfs
Storm frequency	= 5 yrs	Time to peak	= n/a
Time interval	= 1 min	Hyd. volume	= 0 cuft
Inflow hyd. No.	= 2 - Basin #1	Max. Elevation	= 58.94 ft
Reservoir name	= Basin #1	Max. Storage	= 1,285 cuft

Storage Indication method used.

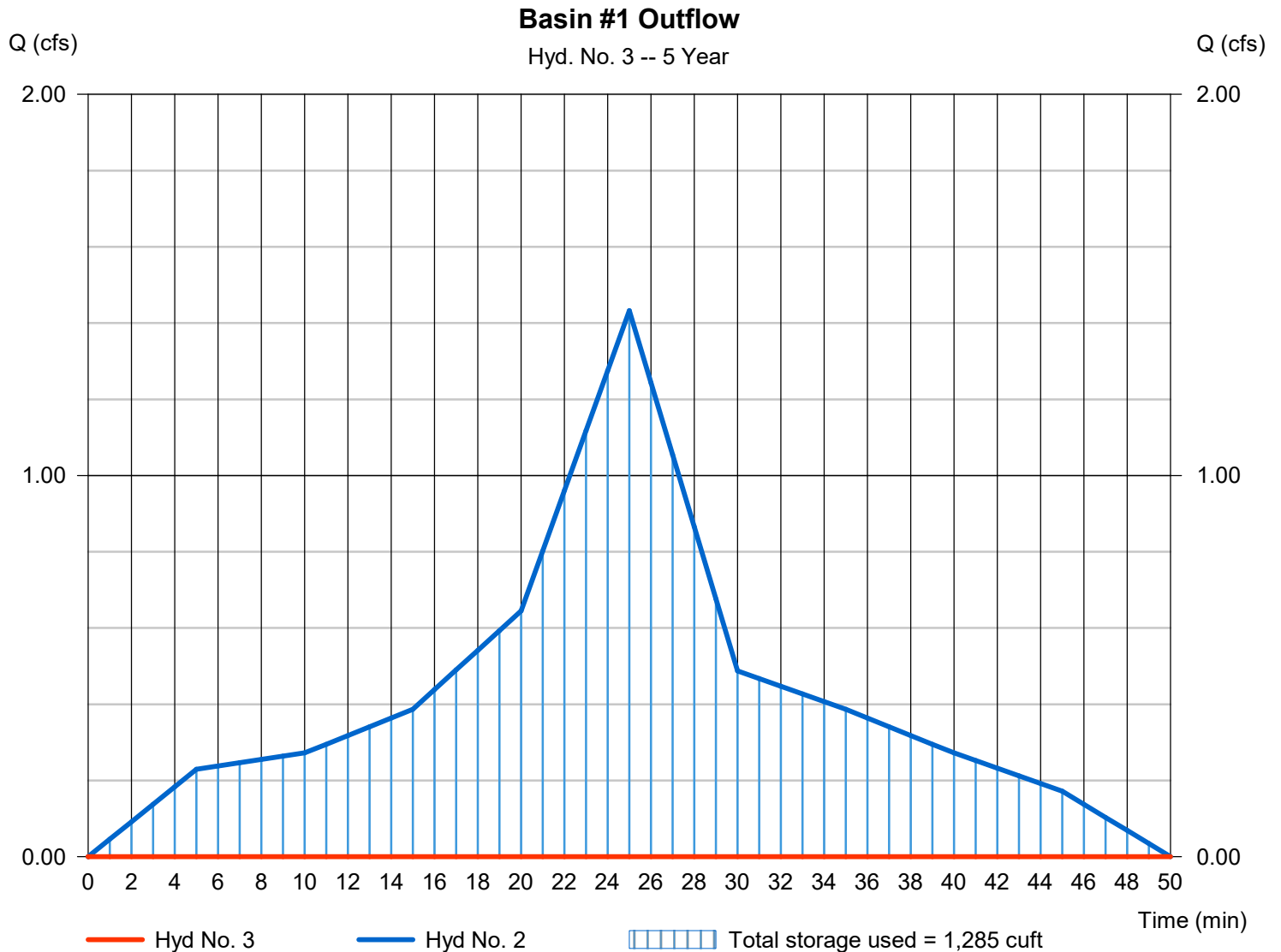

Hydrograph Report

Hyd. No. 4

Bypass

Hydrograph type	= Dekalb	Peak discharge	= 0.568 cfs
Storm frequency	= 5 yrs	Time to peak	= 25 min
Time interval	= 1 min	Hyd. volume	= 509 cuft
Drainage area	= 0.170 ac	Runoff coeff.	= 0.62*
Intensity	= 5.387 in/hr	Tc by User	= 5.00 min
IDF Curve	= Region 5.IDF	Asc/Rec limb fact	= n/a

* Composite (Area/C) = $[(0.090 \times 0.30) + (0.080 \times 0.95)] / 0.170$

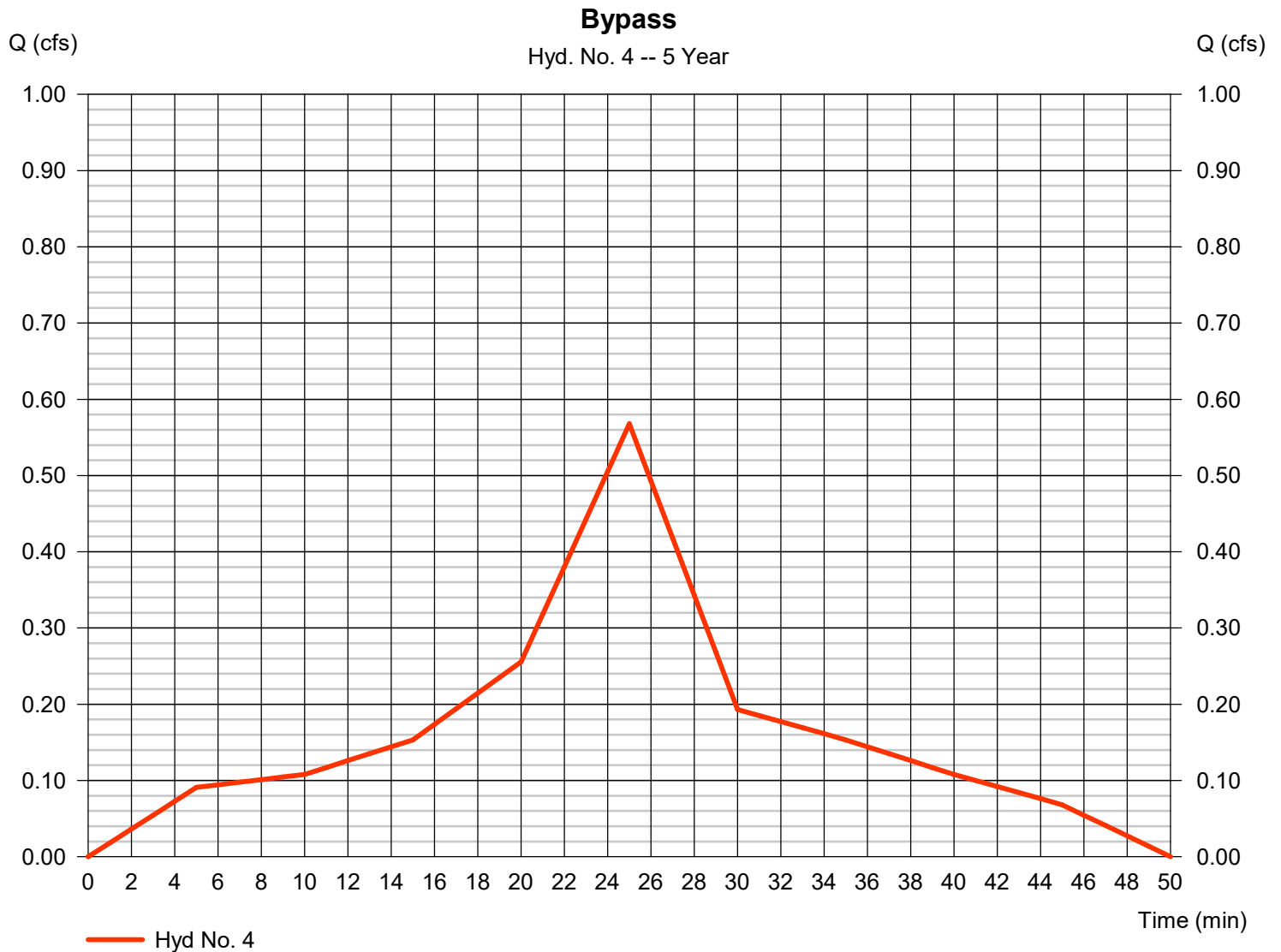

Hydrograph Report

Hyd. No. 5

TOTAL POST

Hydrograph type = Combine
Storm frequency = 5 yrs
Time interval = 1 min
Inflow hyds. = 3, 4

Peak discharge = 0.568 cfs
Time to peak = 25 min
Hyd. volume = 509 cuft
Contrib. drain. area = 0.170 ac

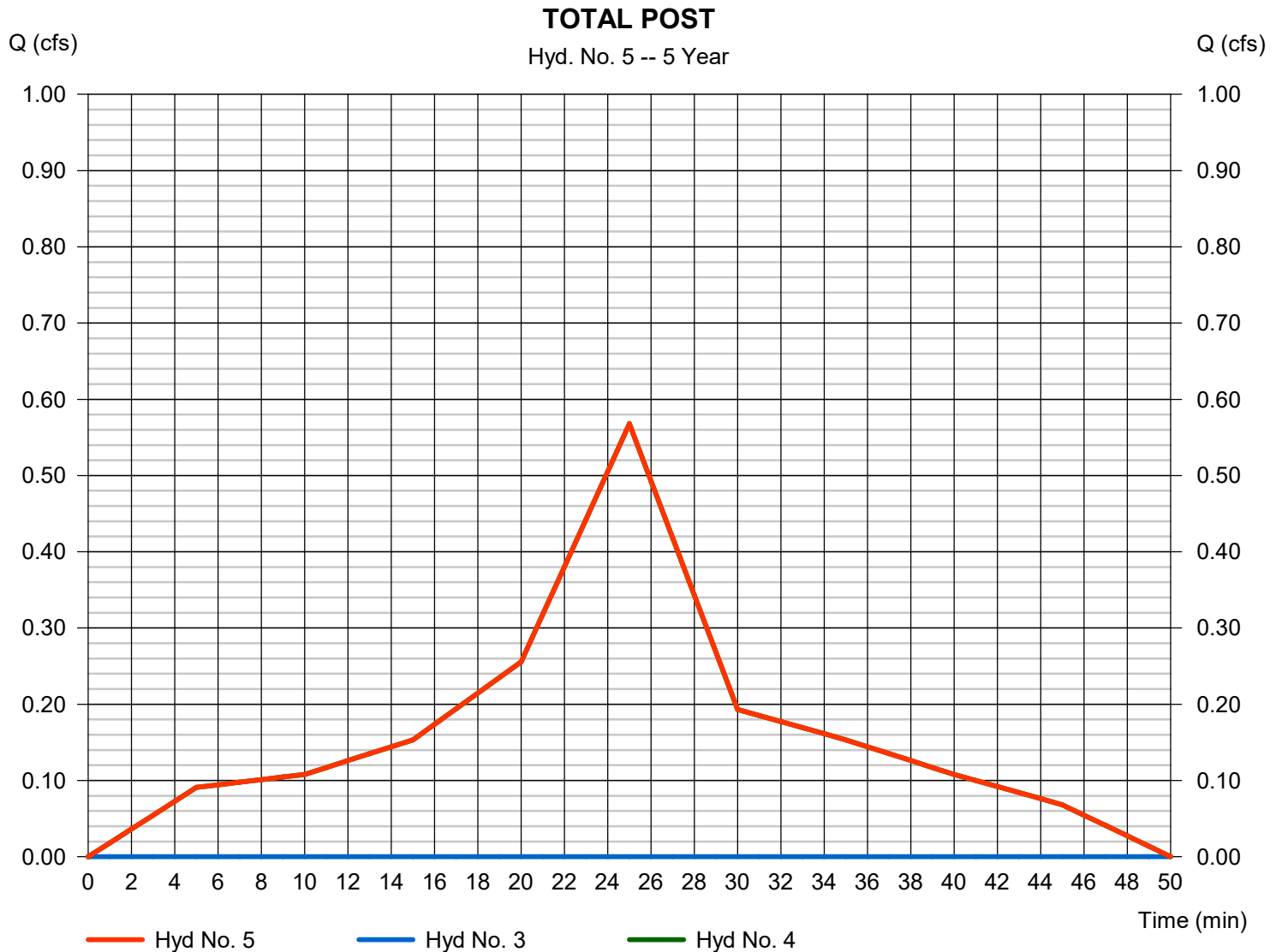

Hydrograph Report

Hydraflow Hydrographs Extension for AutoCAD® Civil 3D® 2018 by Autodesk, Inc. v2018.3

Thursday, 12 / 30 / 2021

Hyd. No. 1

PRE

Hydrograph type	= Dekalb	Peak discharge	= 0.741 cfs
Storm frequency	= 10 yrs	Time to peak	= 25 min
Time interval	= 1 min	Hyd. volume	= 664 cuft
Drainage area	= 0.440 ac	Runoff coeff.	= 0.28*
Intensity	= 6.011 in/hr	Tc by User	= 5.00 min
IDF Curve	= Region 5.IDF	Asc/Rec limb fact	= n/a

* Composite (Area/C) = $[(0.440 \times 0.35)] / 0.440$

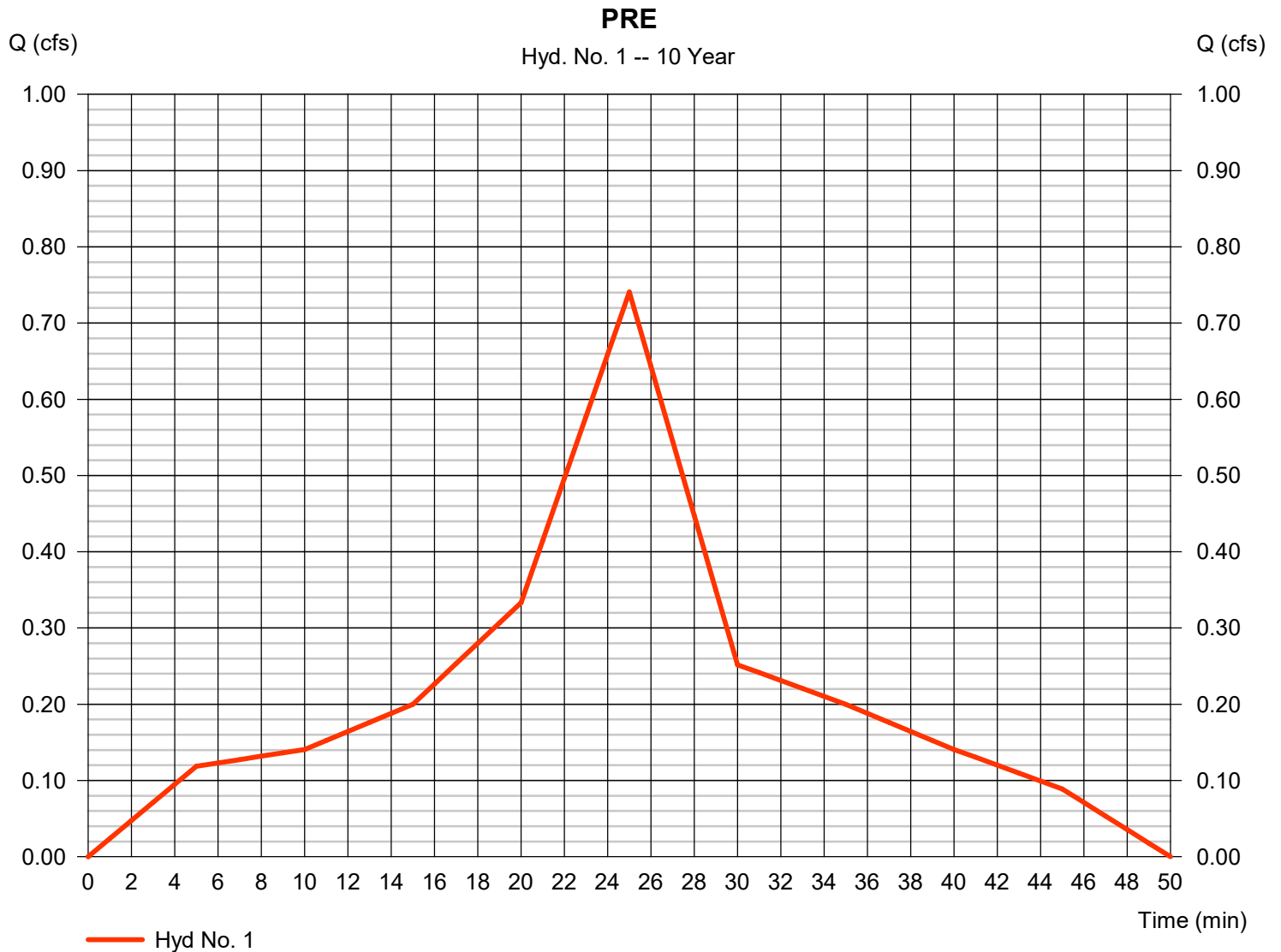

Hydrograph Report

Hyd. No. 2

Basin #1

Hydrograph type	= Dekalb	Peak discharge	= 1.599 cfs
Storm frequency	= 10 yrs	Time to peak	= 25 min
Time interval	= 1 min	Hyd. volume	= 1,434 cuft
Drainage area	= 0.280 ac	Runoff coeff.	= 0.95*
Intensity	= 6.011 in/hr	Tc by User	= 5.00 min
IDF Curve	= Region 5.IDF	Asc/Rec limb fact	= n/a

* Composite (Area/C) = $[(0.210 \times 0.95) + (0.070 \times 0.15)] / 0.280$

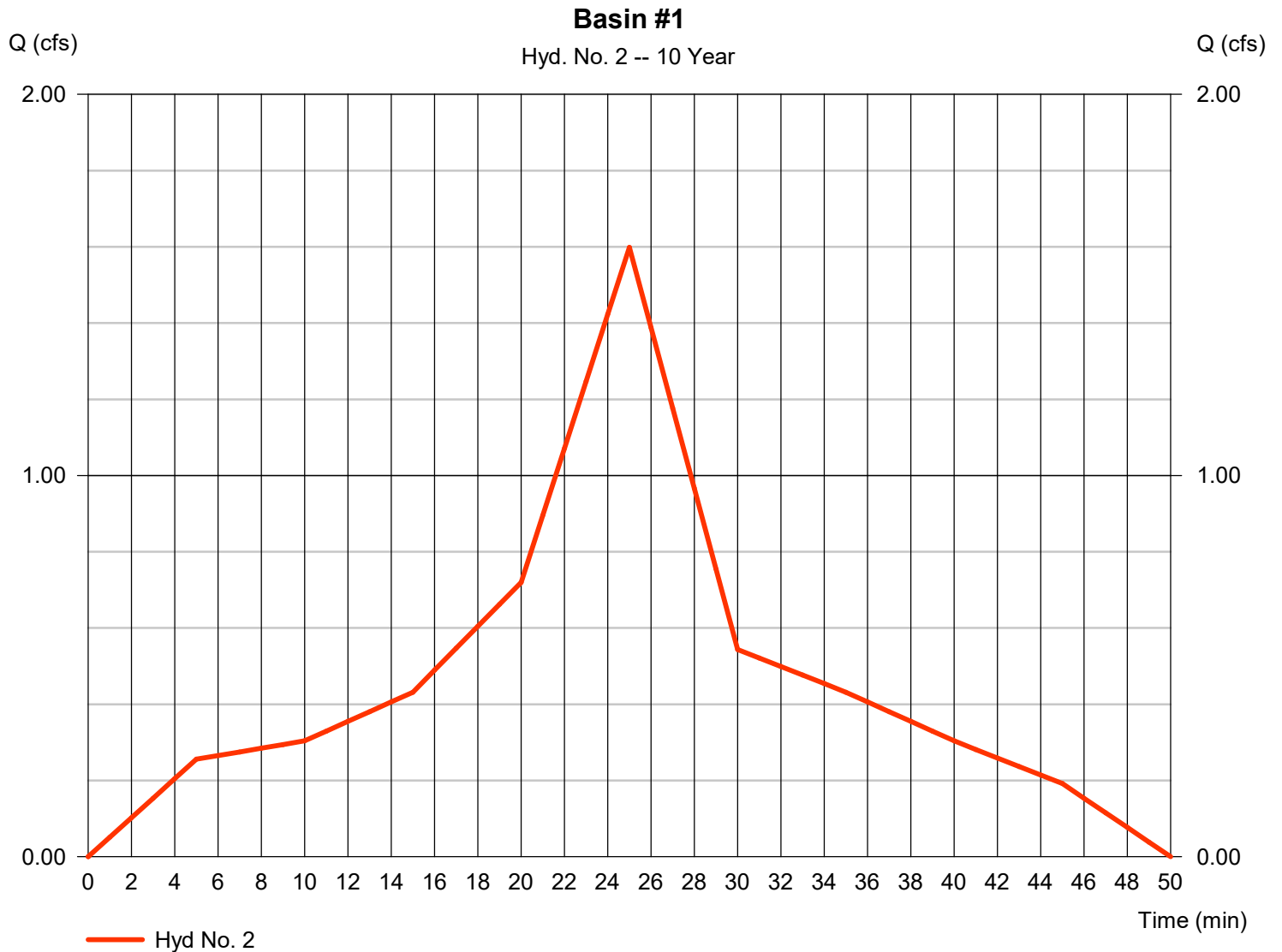

Hydrograph Report

Hyd. No. 3

Basin #1 Outflow

Hydrograph type	= Reservoir	Peak discharge	= 0.000 cfs
Storm frequency	= 10 yrs	Time to peak	= n/a
Time interval	= 1 min	Hyd. volume	= 0 cuft
Inflow hyd. No.	= 2 - Basin #1	Max. Elevation	= 59.14 ft
Reservoir name	= Basin #1	Max. Storage	= 1,434 cuft

Storage Indication method used.

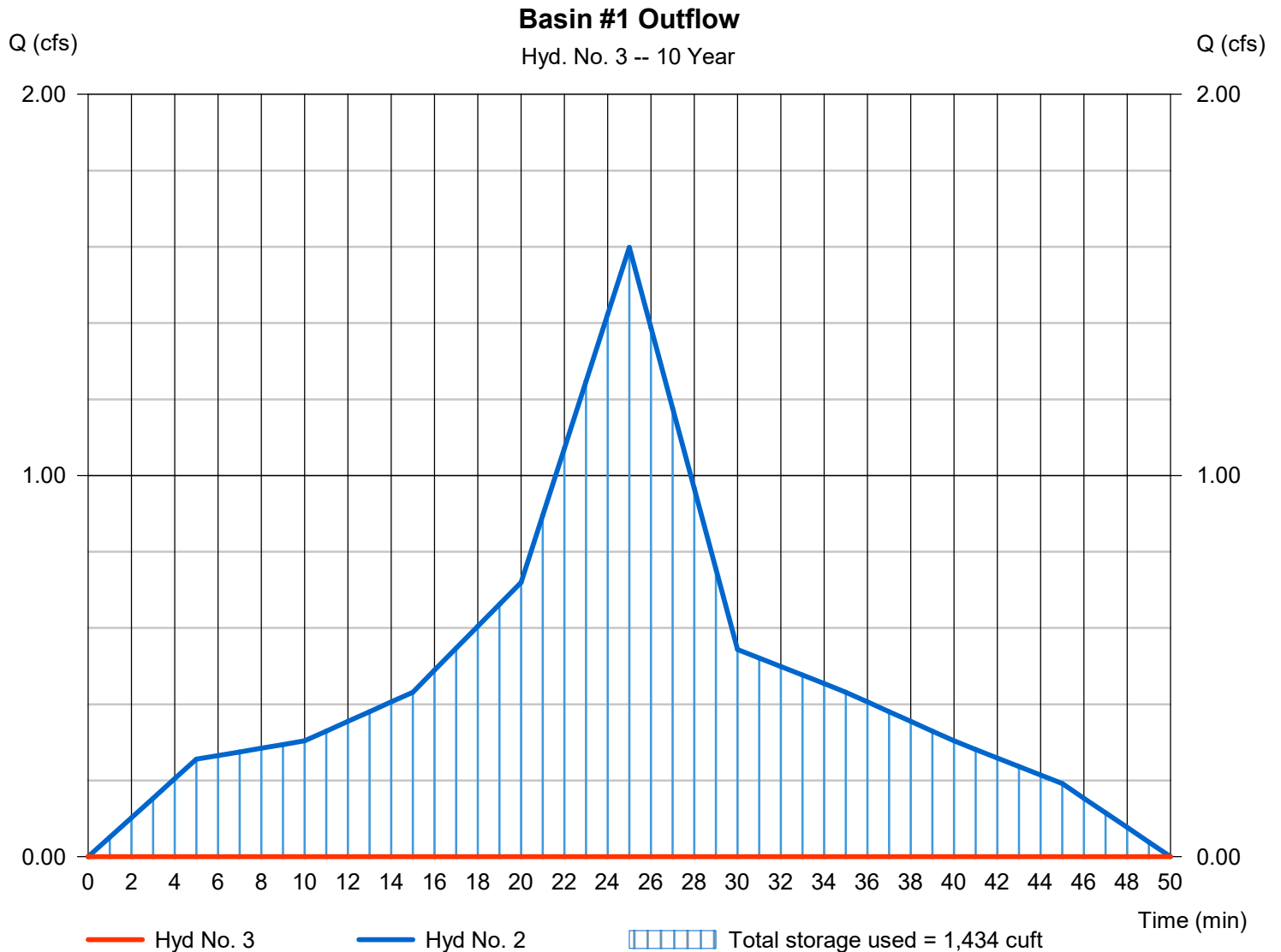

Hydrograph Report

Hyd. No. 4

Bypass

Hydrograph type	= Dekalb	Peak discharge	= 0.634 cfs
Storm frequency	= 10 yrs	Time to peak	= 25 min
Time interval	= 1 min	Hyd. volume	= 568 cuft
Drainage area	= 0.170 ac	Runoff coeff.	= 0.62*
Intensity	= 6.011 in/hr	Tc by User	= 5.00 min
IDF Curve	= Region 5.IDF	Asc/Rec limb fact	= n/a

* Composite (Area/C) = $[(0.090 \times 0.30) + (0.080 \times 0.95)] / 0.170$

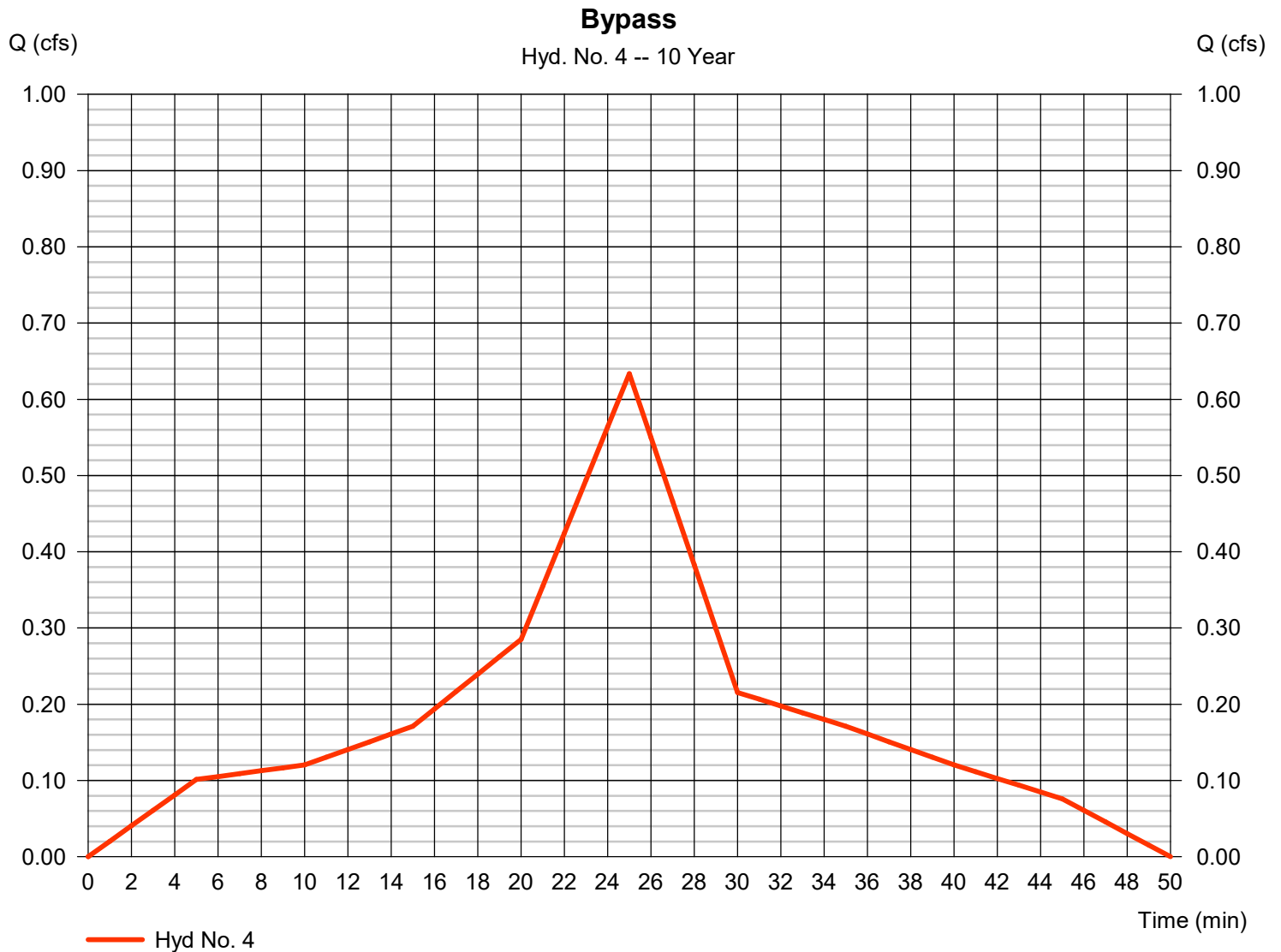

Hydrograph Report

Hyd. No. 5

TOTAL POST

Hydrograph type = Combine
Storm frequency = 10 yrs
Time interval = 1 min
Inflow hyds. = 3, 4

Peak discharge = 0.634 cfs
Time to peak = 25 min
Hyd. volume = 568 cuft
Contrib. drain. area = 0.170 ac

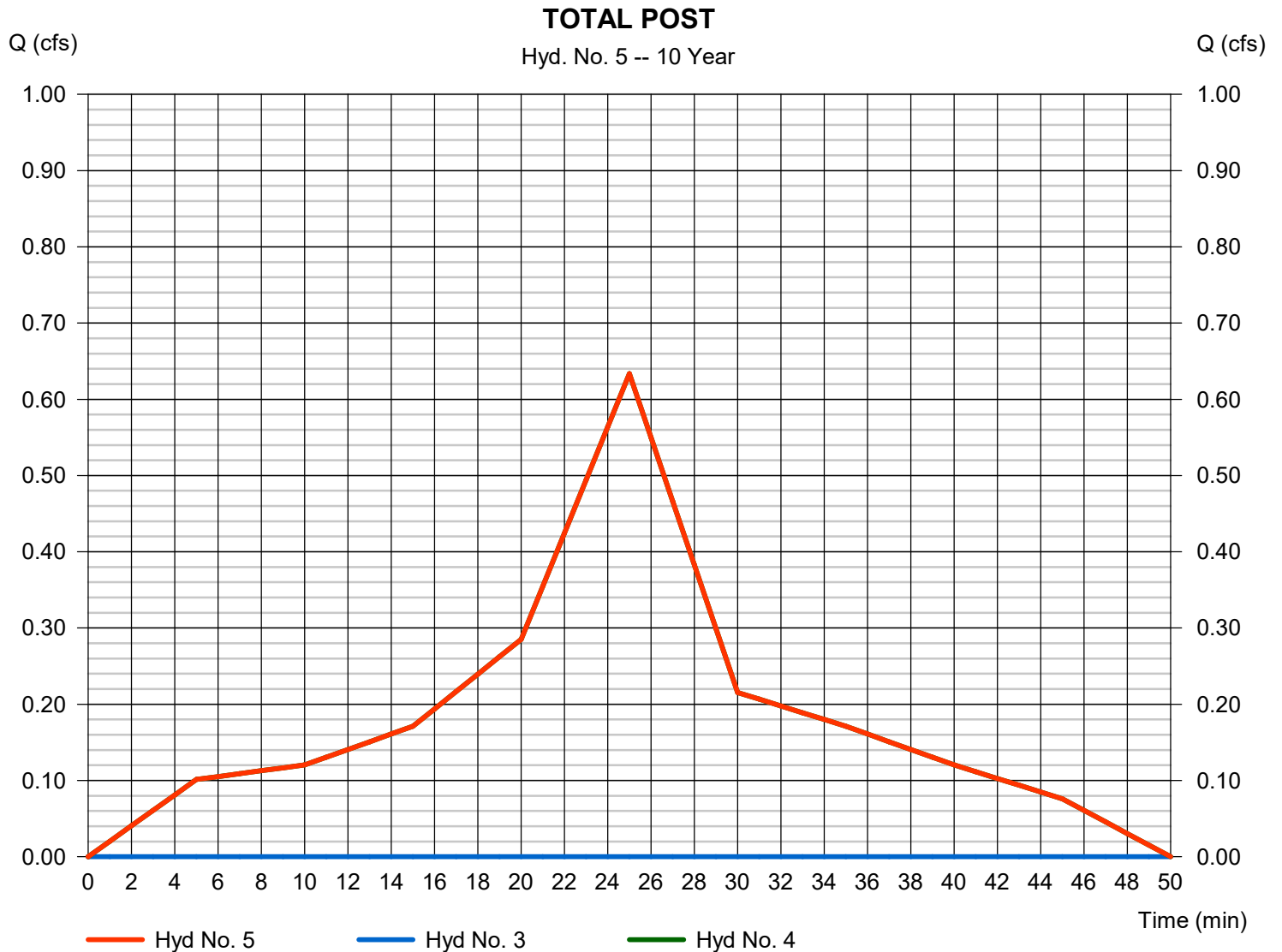

Hydrograph Report

Hyd. No. 1

PRE

Hydrograph type	= Dekalb	Peak discharge	= 0.825 cfs
Storm frequency	= 25 yrs	Time to peak	= 25 min
Time interval	= 1 min	Hyd. volume	= 740 cuft
Drainage area	= 0.440 ac	Runoff coeff.	= 0.28*
Intensity	= 6.698 in/hr	Tc by User	= 5.00 min
IDF Curve	= Region 5.IDF	Asc/Rec limb fact	= n/a

* Composite (Area/C) = $[(0.440 \times 0.35)] / 0.440$

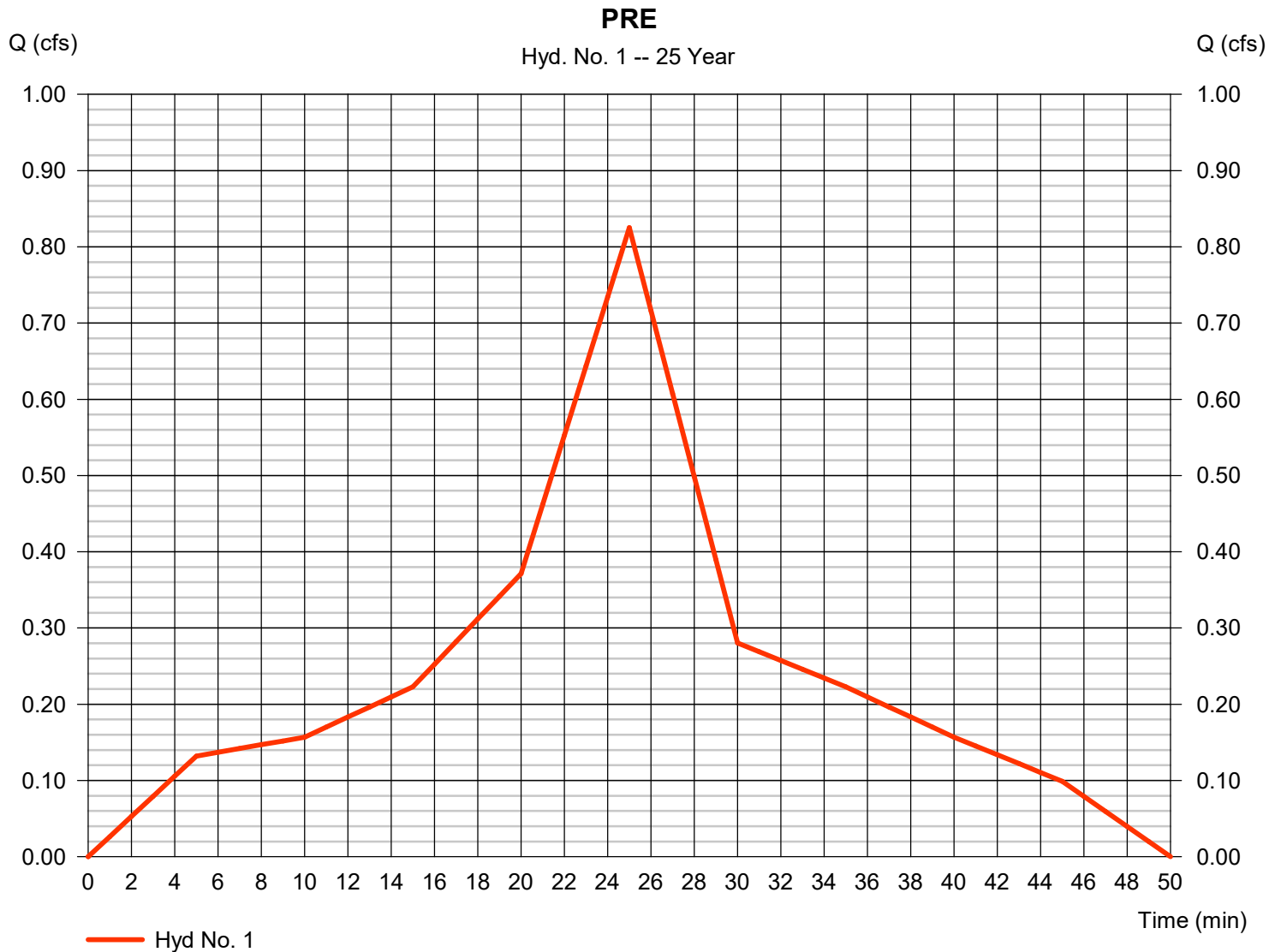

Hydrograph Report

Hyd. No. 2

Basin #1

Hydrograph type	= Dekalb	Peak discharge	= 1.782 cfs
Storm frequency	= 25 yrs	Time to peak	= 25 min
Time interval	= 1 min	Hyd. volume	= 1,598 cuft
Drainage area	= 0.280 ac	Runoff coeff.	= 0.95*
Intensity	= 6.698 in/hr	Tc by User	= 5.00 min
IDF Curve	= Region 5.IDF	Asc/Rec limb fact	= n/a

* Composite (Area/C) = $[(0.210 \times 0.95) + (0.070 \times 0.15)] / 0.280$

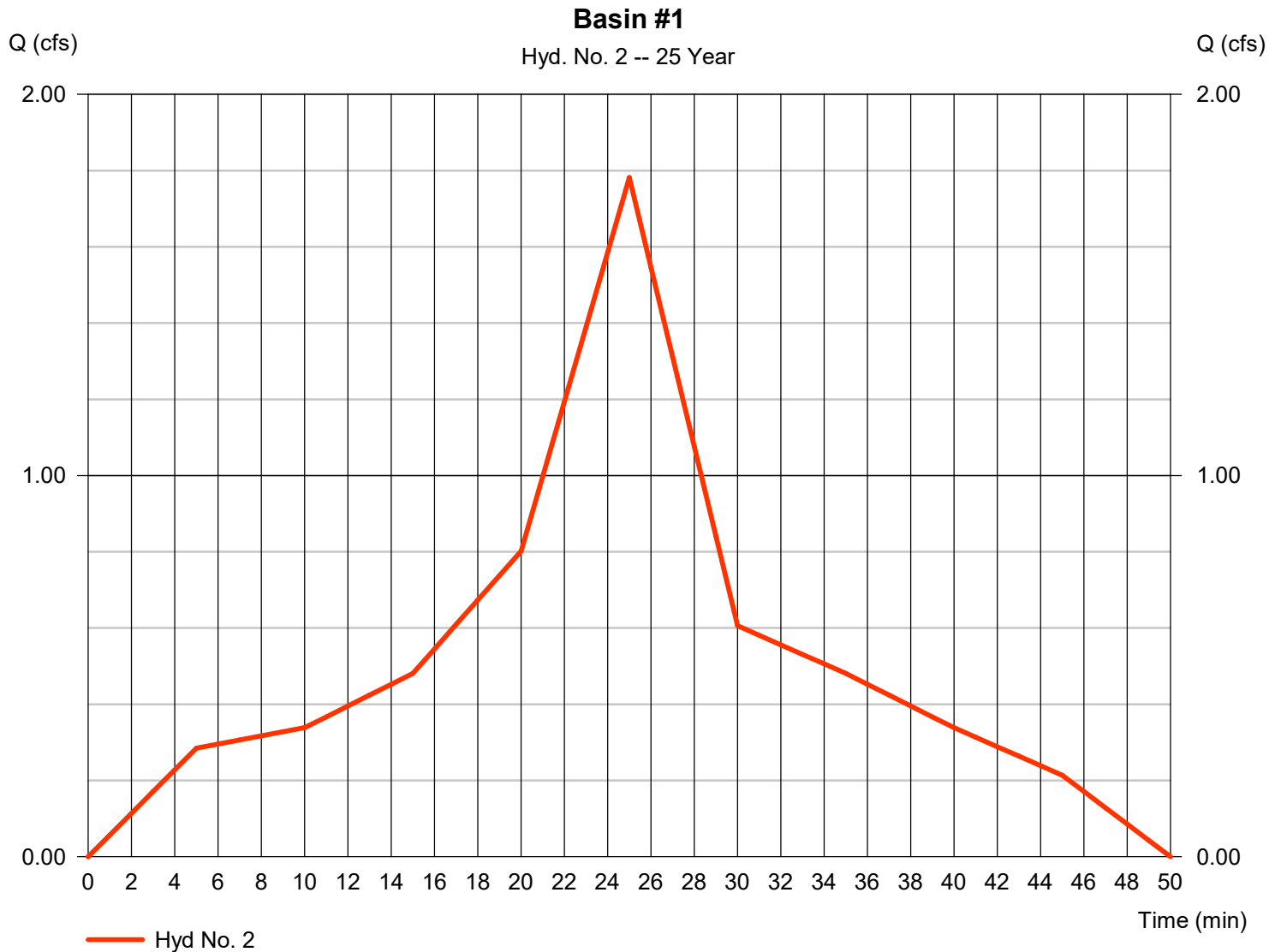

Hydrograph Report

Hyd. No. 3

Basin #1 Outflow

Hydrograph type	= Reservoir	Peak discharge	= 0.000 cfs
Storm frequency	= 25 yrs	Time to peak	= n/a
Time interval	= 1 min	Hyd. volume	= 0 cuft
Inflow hyd. No.	= 2 - Basin #1	Max. Elevation	= 59.36 ft
Reservoir name	= Basin #1	Max. Storage	= 1,598 cuft

Storage Indication method used.

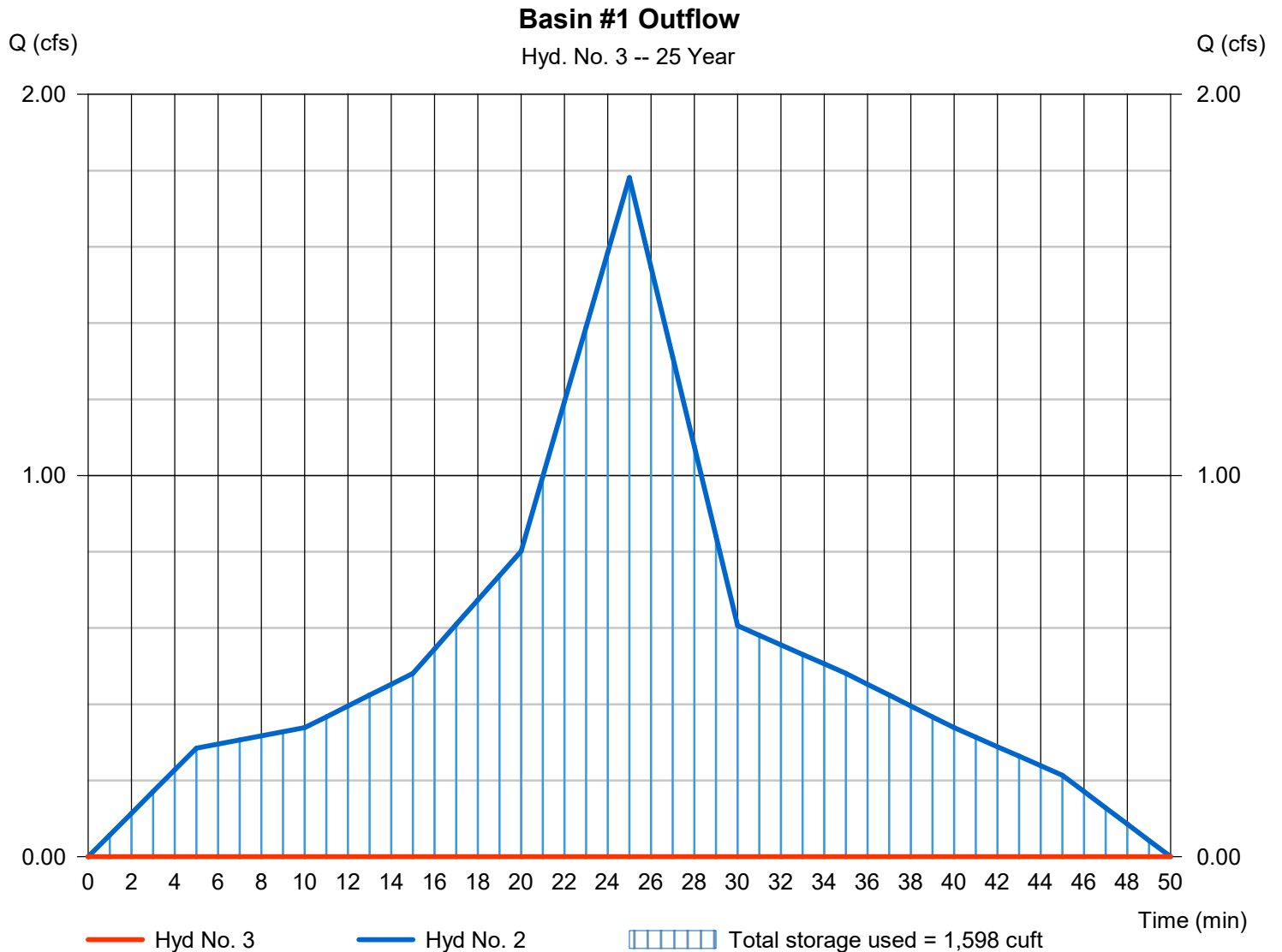

Hydrograph Report

Hyd. No. 4

Bypass

Hydrograph type	= Dekalb	Peak discharge	= 0.706 cfs
Storm frequency	= 25 yrs	Time to peak	= 25 min
Time interval	= 1 min	Hyd. volume	= 633 cuft
Drainage area	= 0.170 ac	Runoff coeff.	= 0.62*
Intensity	= 6.698 in/hr	Tc by User	= 5.00 min
IDF Curve	= Region 5.IDF	Asc/Rec limb fact	= n/a

* Composite (Area/C) = $[(0.090 \times 0.30) + (0.080 \times 0.95)] / 0.170$

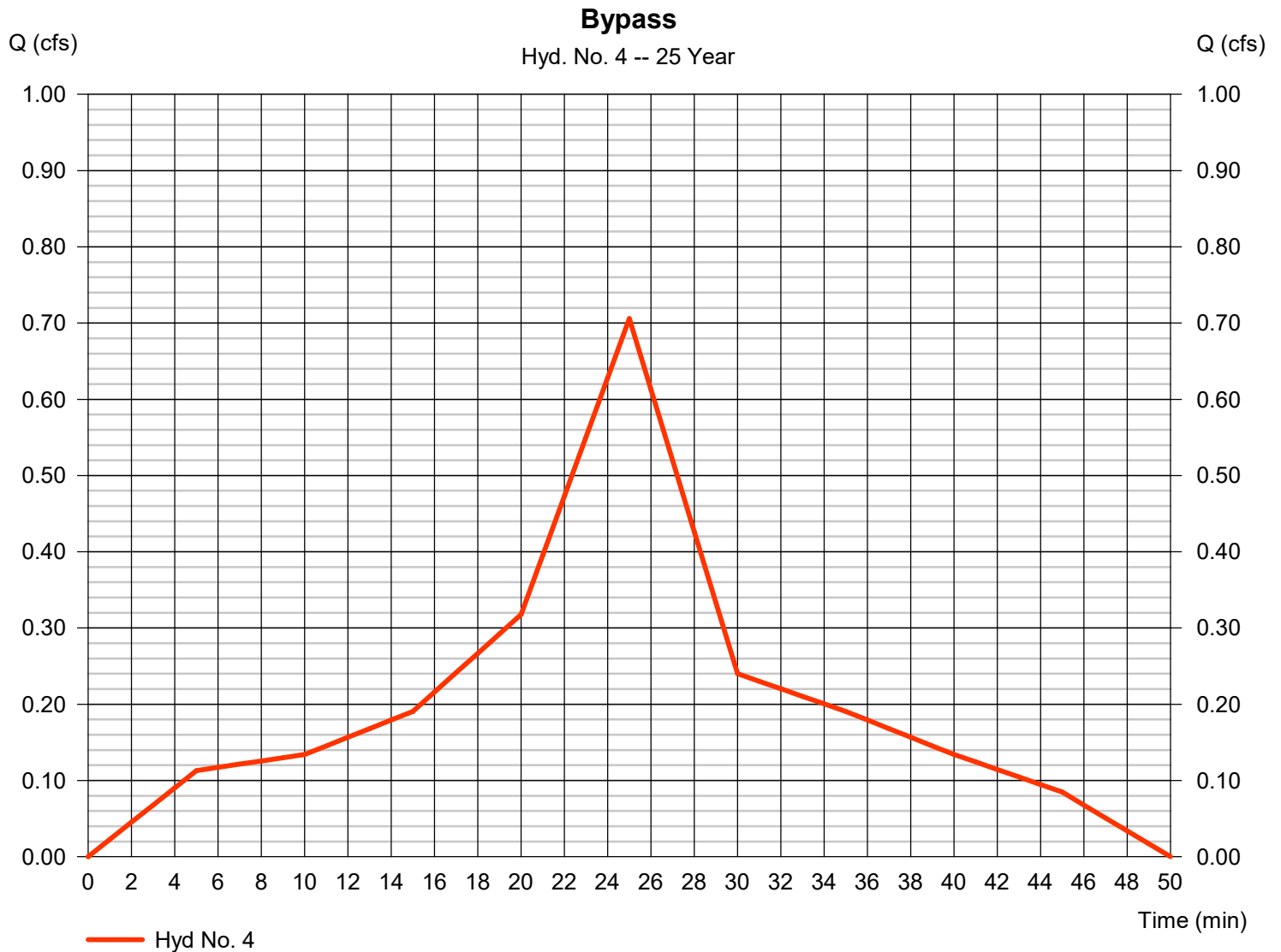

Hydrograph Report

Hyd. No. 5

TOTAL POST

Hydrograph type = Combine
Storm frequency = 25 yrs
Time interval = 1 min
Inflow hyds. = 3, 4

Peak discharge = 0.706 cfs
Time to peak = 25 min
Hyd. volume = 633 cuft
Contrib. drain. area = 0.170 ac

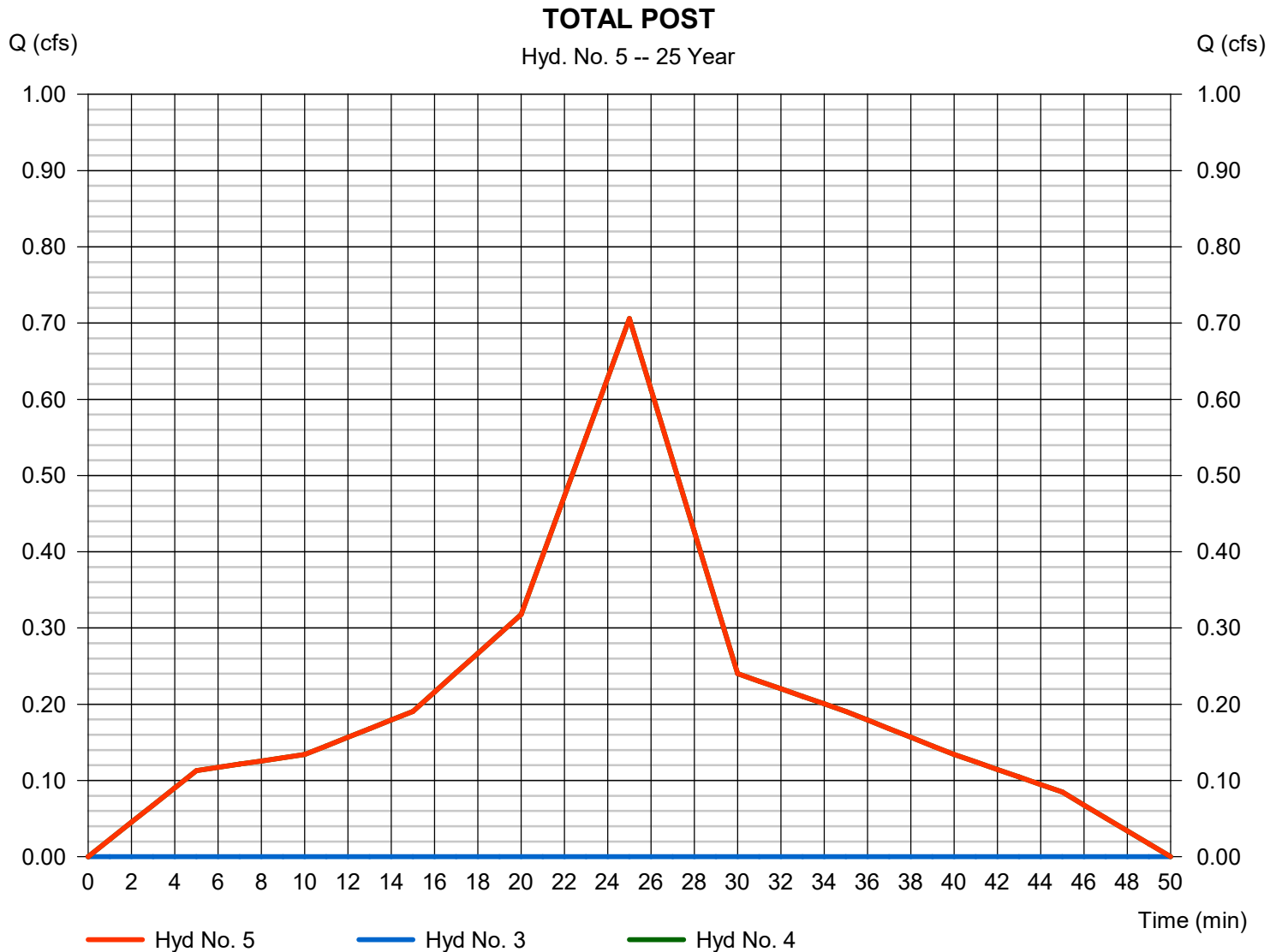

Hydrograph Report

Hyd. No. 1

PRE

Hydrograph type	= Dekalb	Peak discharge	= 0.924 cfs
Storm frequency	= 50 yrs	Time to peak	= 25 min
Time interval	= 1 min	Hyd. volume	= 828 cuft
Drainage area	= 0.440 ac	Runoff coeff.	= 0.28*
Intensity	= 7.497 in/hr	Tc by User	= 5.00 min
IDF Curve	= Region 5.IDF	Asc/Rec limb fact	= n/a

* Composite (Area/C) = $[(0.440 \times 0.35)] / 0.440$

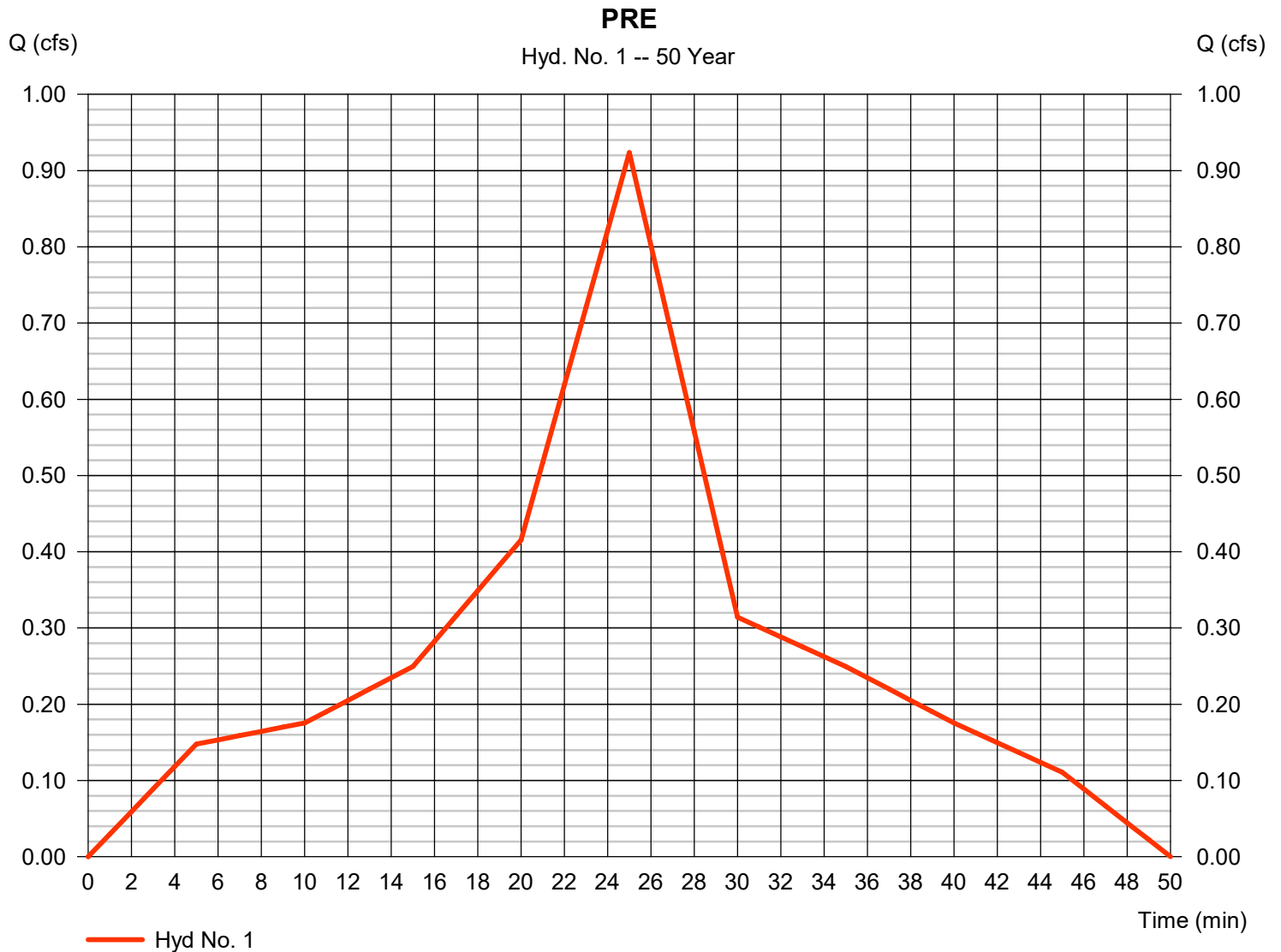

Hydrograph Report

Hyd. No. 2

Basin #1

Hydrograph type	= Dekalb	Peak discharge	= 1.994 cfs
Storm frequency	= 50 yrs	Time to peak	= 25 min
Time interval	= 1 min	Hyd. volume	= 1,789 cuft
Drainage area	= 0.280 ac	Runoff coeff.	= 0.95*
Intensity	= 7.497 in/hr	Tc by User	= 5.00 min
IDF Curve	= Region 5.IDF	Asc/Rec limb fact	= n/a

* Composite (Area/C) = $[(0.210 \times 0.95) + (0.070 \times 0.15)] / 0.280$

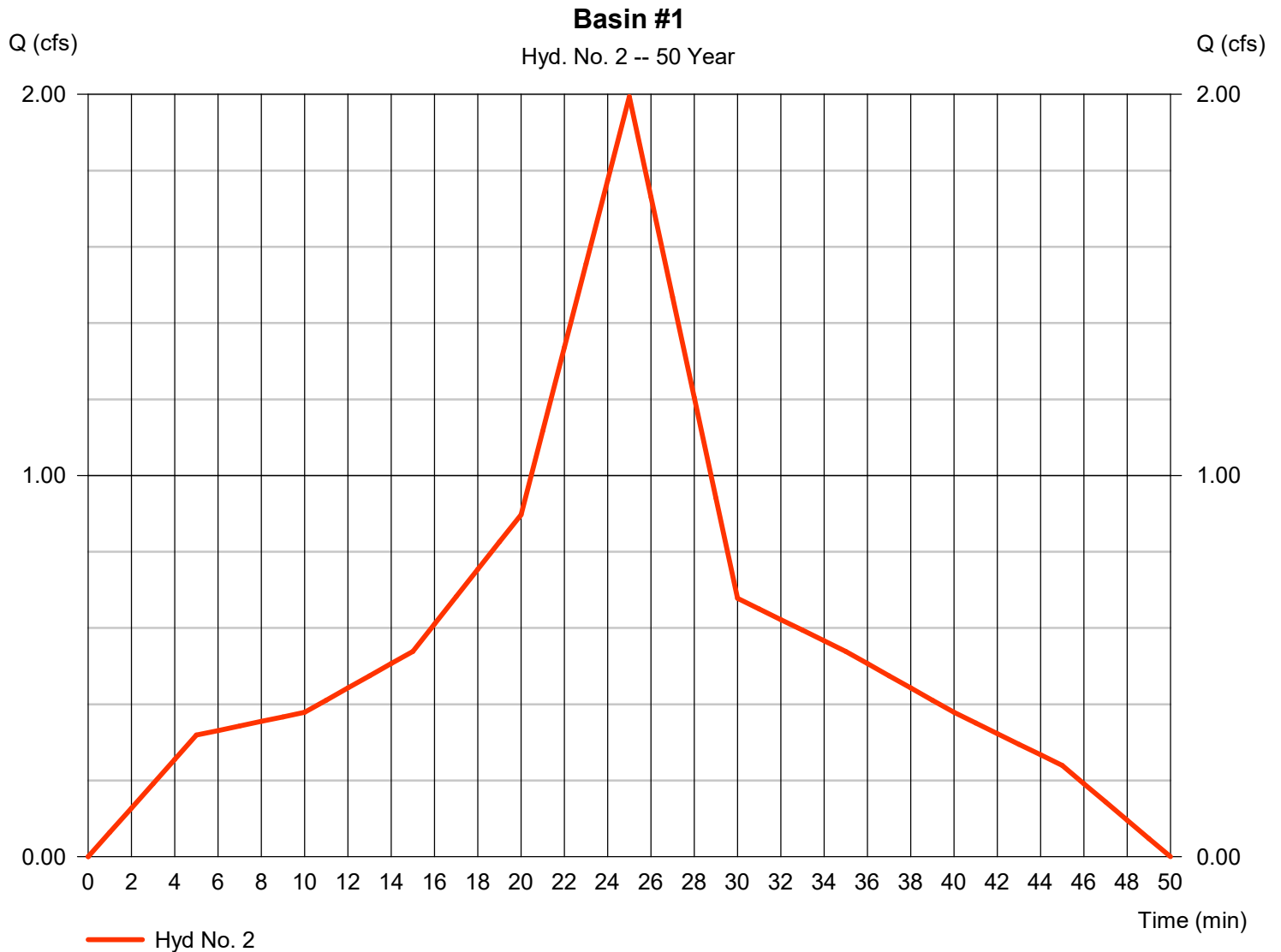

Hydrograph Report

Hyd. No. 3

Basin #1 Outflow

Hydrograph type	= Reservoir	Peak discharge	= 0.070 cfs
Storm frequency	= 50 yrs	Time to peak	= 49 min
Time interval	= 1 min	Hyd. volume	= 85 cuft
Inflow hyd. No.	= 2 - Basin #1	Max. Elevation	= 59.59 ft
Reservoir name	= Basin #1	Max. Storage	= 1,767 cuft

Storage Indication method used.

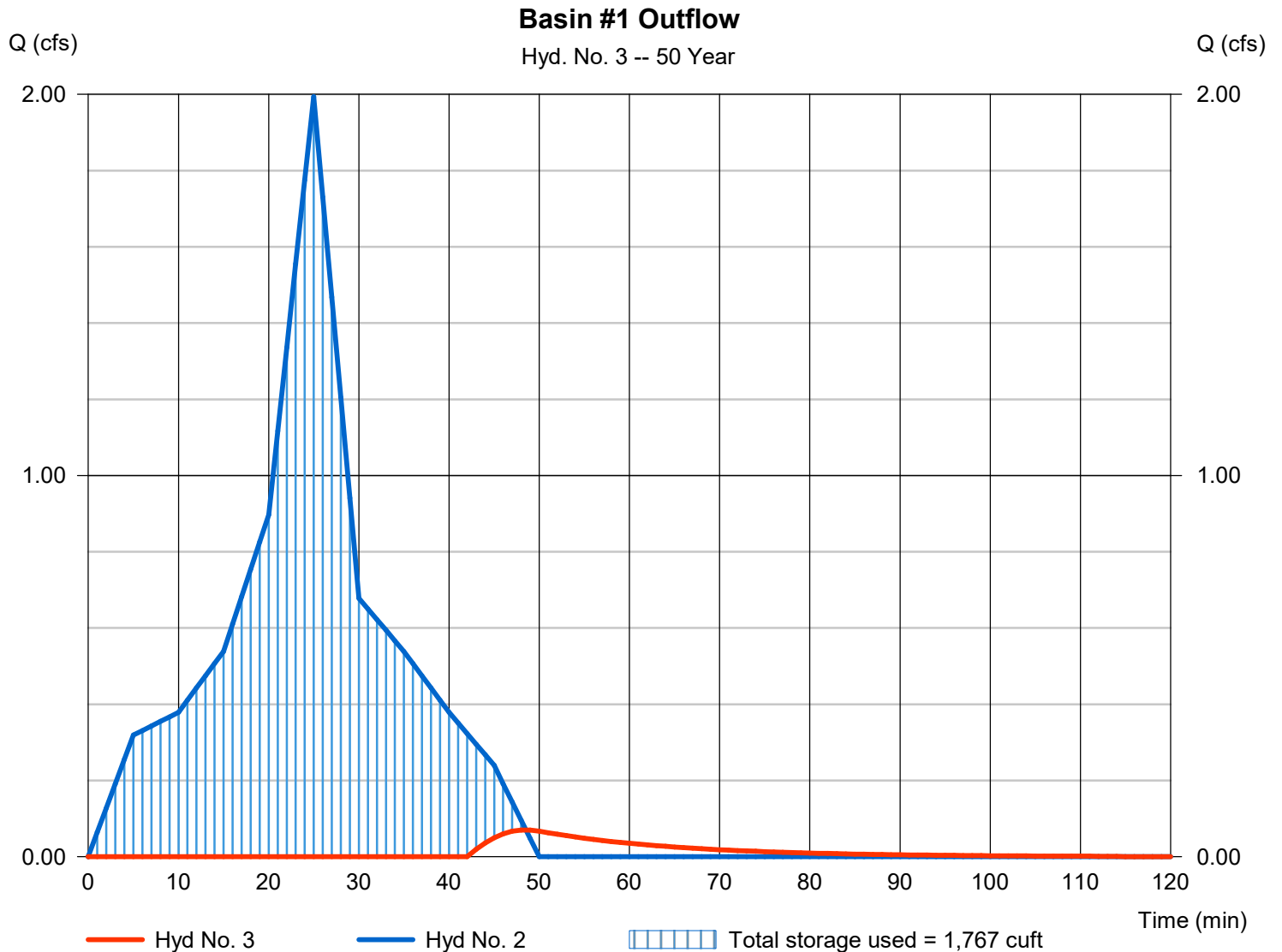

Hydrograph Report

Hyd. No. 4

Bypass

Hydrograph type	= Dekalb	Peak discharge	= 0.790 cfs
Storm frequency	= 50 yrs	Time to peak	= 25 min
Time interval	= 1 min	Hyd. volume	= 709 cuft
Drainage area	= 0.170 ac	Runoff coeff.	= 0.62*
Intensity	= 7.497 in/hr	Tc by User	= 5.00 min
IDF Curve	= Region 5.IDF	Asc/Rec limb fact	= n/a

* Composite (Area/C) = $[(0.090 \times 0.30) + (0.080 \times 0.95)] / 0.170$

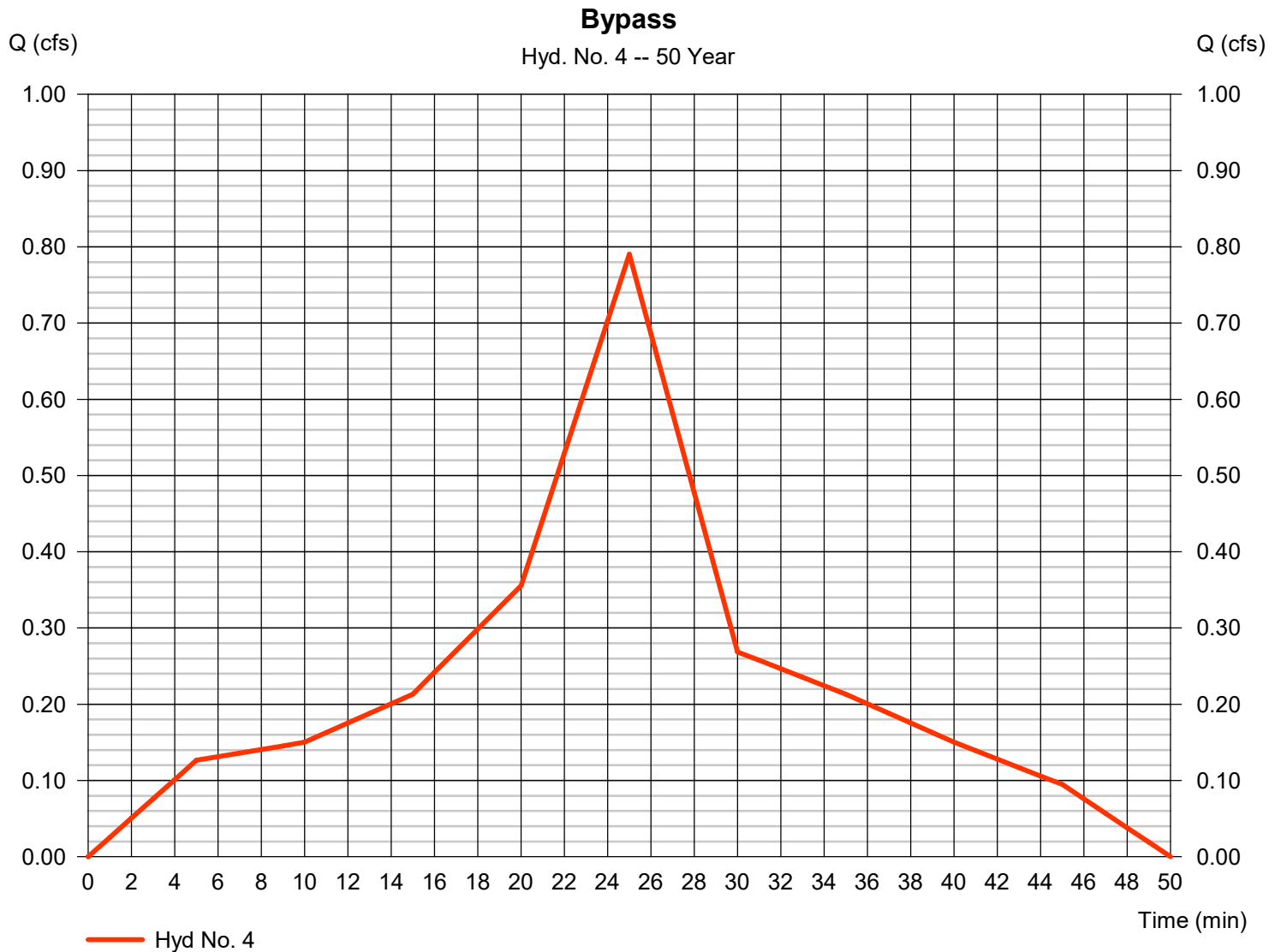

Hydrograph Report

Hyd. No. 5

TOTAL POST

Hydrograph type = Combine
Storm frequency = 50 yrs
Time interval = 1 min
Inflow hyds. = 3, 4

Peak discharge = 0.790 cfs
Time to peak = 25 min
Hyd. volume = 794 cuft
Contrib. drain. area = 0.170 ac

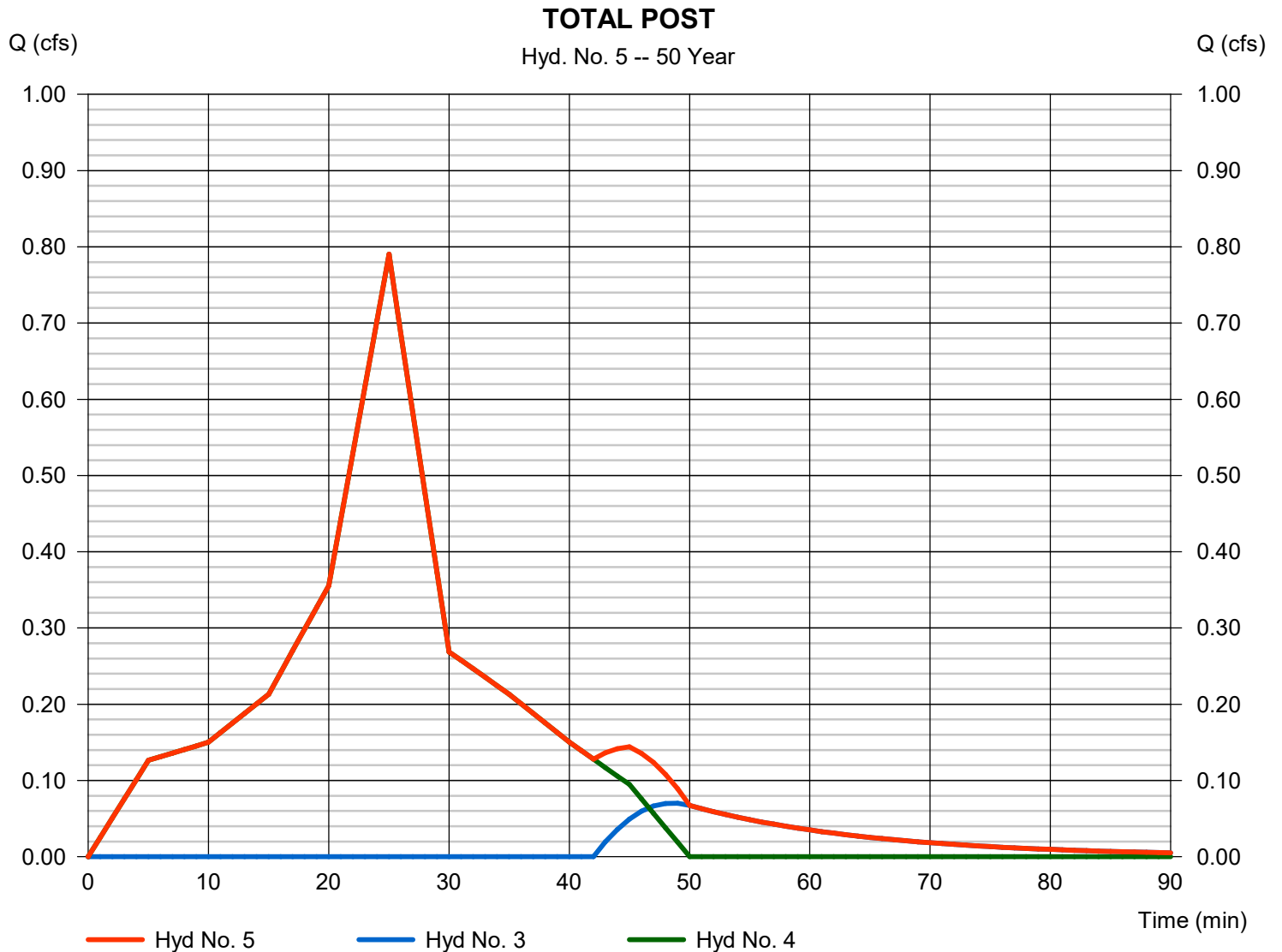

Hydrograph Report

Hyd. No. 1

PRE

Hydrograph type	= Dekalb	Peak discharge	= 1.008 cfs
Storm frequency	= 100 yrs	Time to peak	= 25 min
Time interval	= 1 min	Hyd. volume	= 904 cuft
Drainage area	= 0.440 ac	Runoff coeff.	= 0.28*
Intensity	= 8.183 in/hr	Tc by User	= 5.00 min
IDF Curve	= Region 5.IDF	Asc/Rec limb fact	= n/a

* Composite (Area/C) = $[(0.440 \times 0.35)] / 0.440$

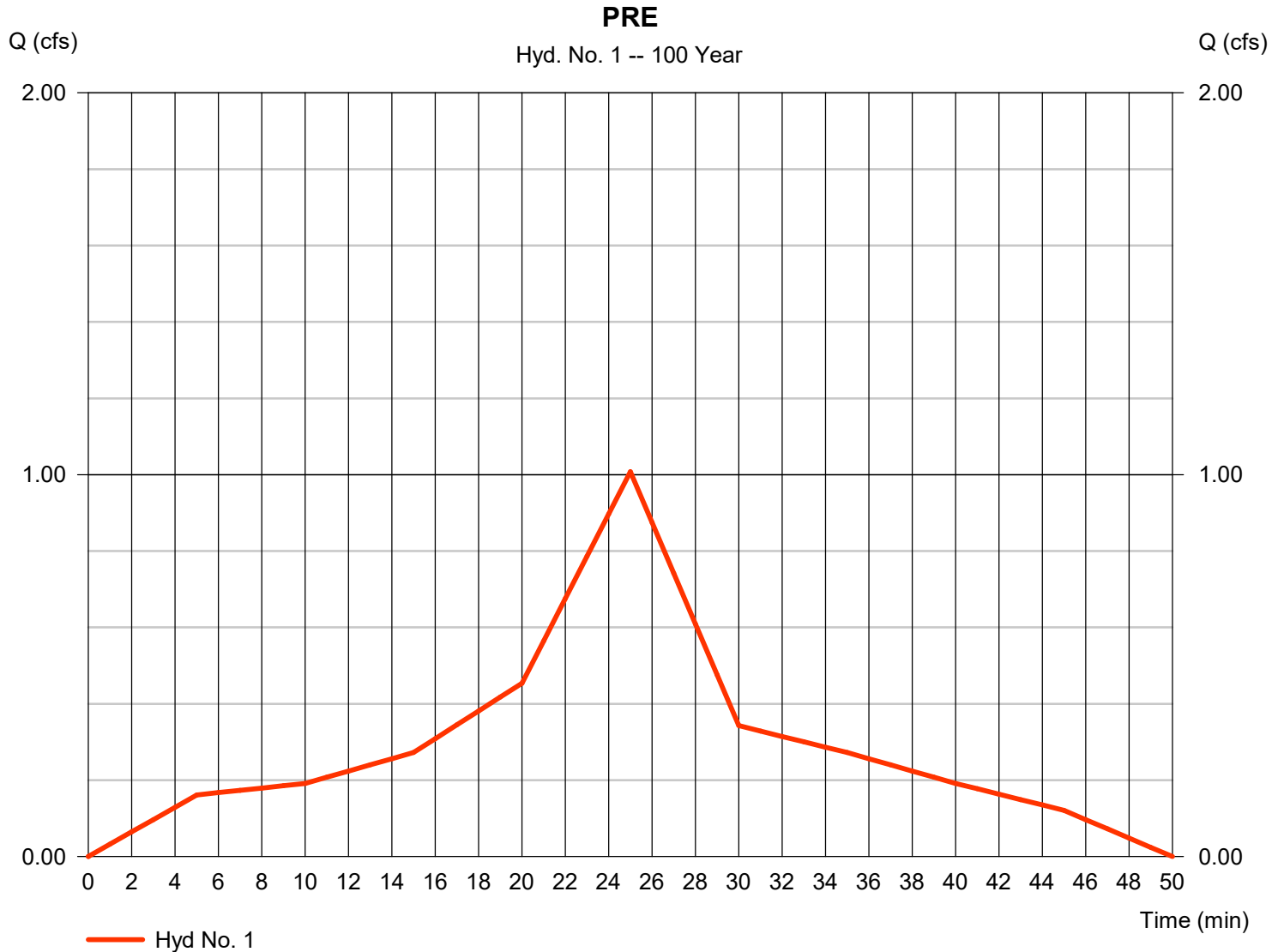

Hydrograph Report

Hyd. No. 2

Basin #1

Hydrograph type	= Dekalb	Peak discharge	= 2.177 cfs
Storm frequency	= 100 yrs	Time to peak	= 25 min
Time interval	= 1 min	Hyd. volume	= 1,952 cuft
Drainage area	= 0.280 ac	Runoff coeff.	= 0.95*
Intensity	= 8.183 in/hr	Tc by User	= 5.00 min
IDF Curve	= Region 5.IDF	Asc/Rec limb fact	= n/a

* Composite (Area/C) = $[(0.210 \times 0.95) + (0.070 \times 0.15)] / 0.280$

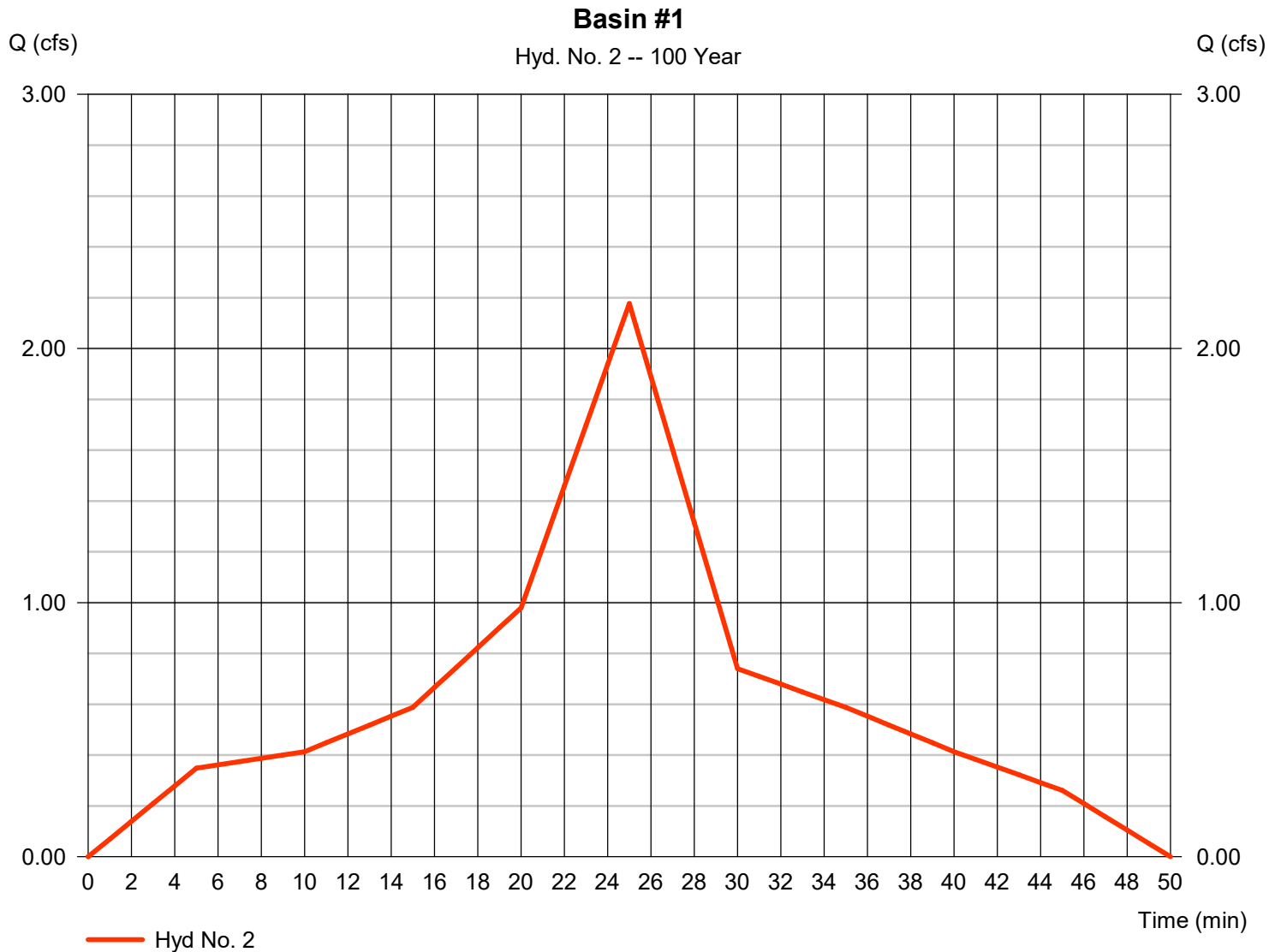

Hydrograph Report

Hyd. No. 3

Basin #1 Outflow

Hydrograph type	= Reservoir	Peak discharge	= 0.227 cfs
Storm frequency	= 100 yrs	Time to peak	= 46 min
Time interval	= 1 min	Hyd. volume	= 249 cuft
Inflow hyd. No.	= 2 - Basin #1	Max. Elevation	= 59.70 ft
Reservoir name	= Basin #1	Max. Storage	= 1,849 cuft

Storage Indication method used.

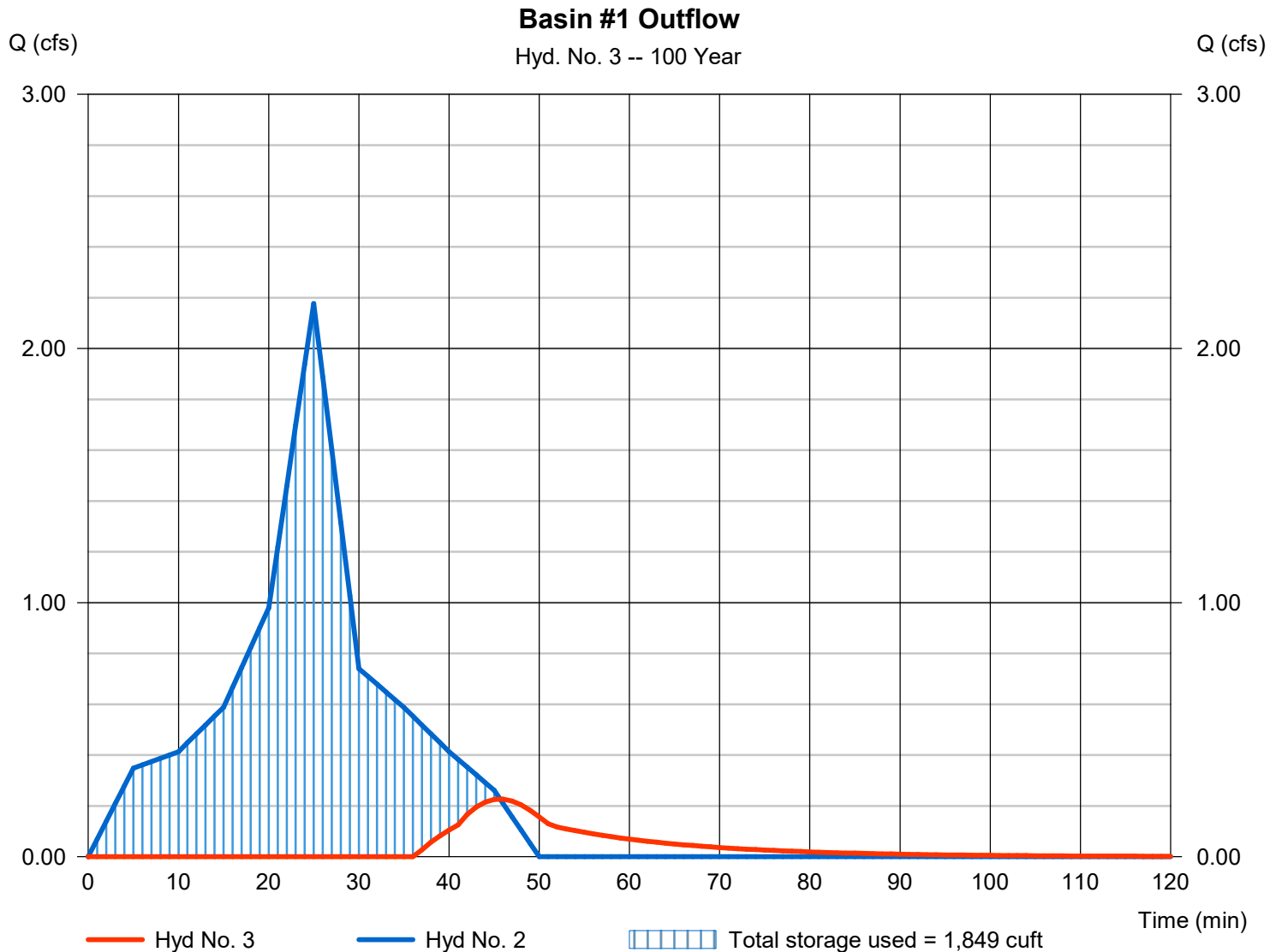

Hydrograph Report

Hyd. No. 4

Bypass

Hydrograph type	= Dekalb	Peak discharge	= 0.862 cfs
Storm frequency	= 100 yrs	Time to peak	= 25 min
Time interval	= 1 min	Hyd. volume	= 774 cuft
Drainage area	= 0.170 ac	Runoff coeff.	= 0.62*
Intensity	= 8.183 in/hr	Tc by User	= 5.00 min
IDF Curve	= Region 5.IDF	Asc/Rec limb fact	= n/a

* Composite (Area/C) = $[(0.090 \times 0.30) + (0.080 \times 0.95)] / 0.170$

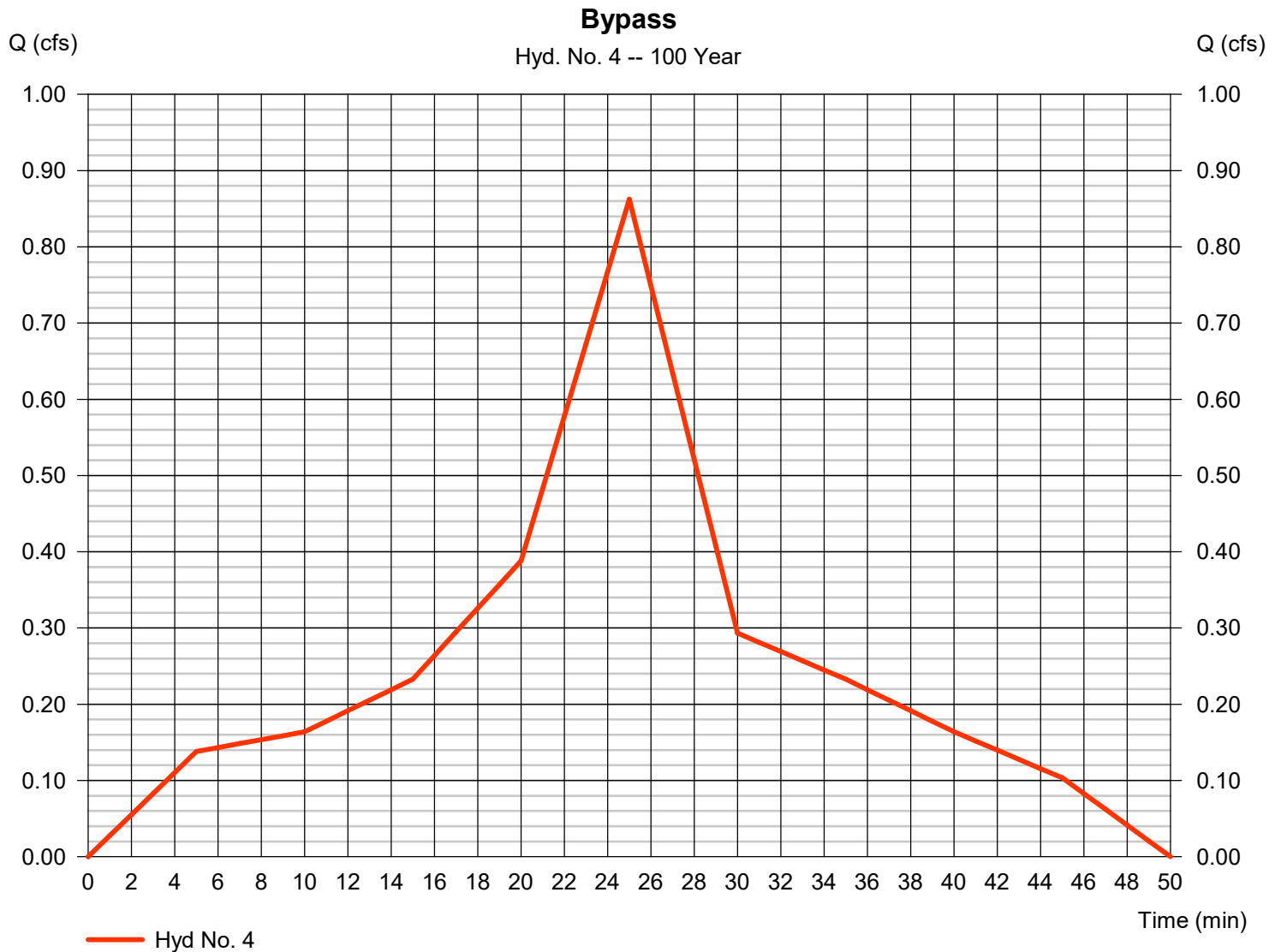

Hydrograph Report

Hyd. No. 5

TOTAL POST

Hydrograph type = Combine
Storm frequency = 100 yrs
Time interval = 1 min
Inflow hyds. = 3, 4

Peak discharge = 0.862 cfs
Time to peak = 25 min
Hyd. volume = 1,023 cuft
Contrib. drain. area = 0.170 ac

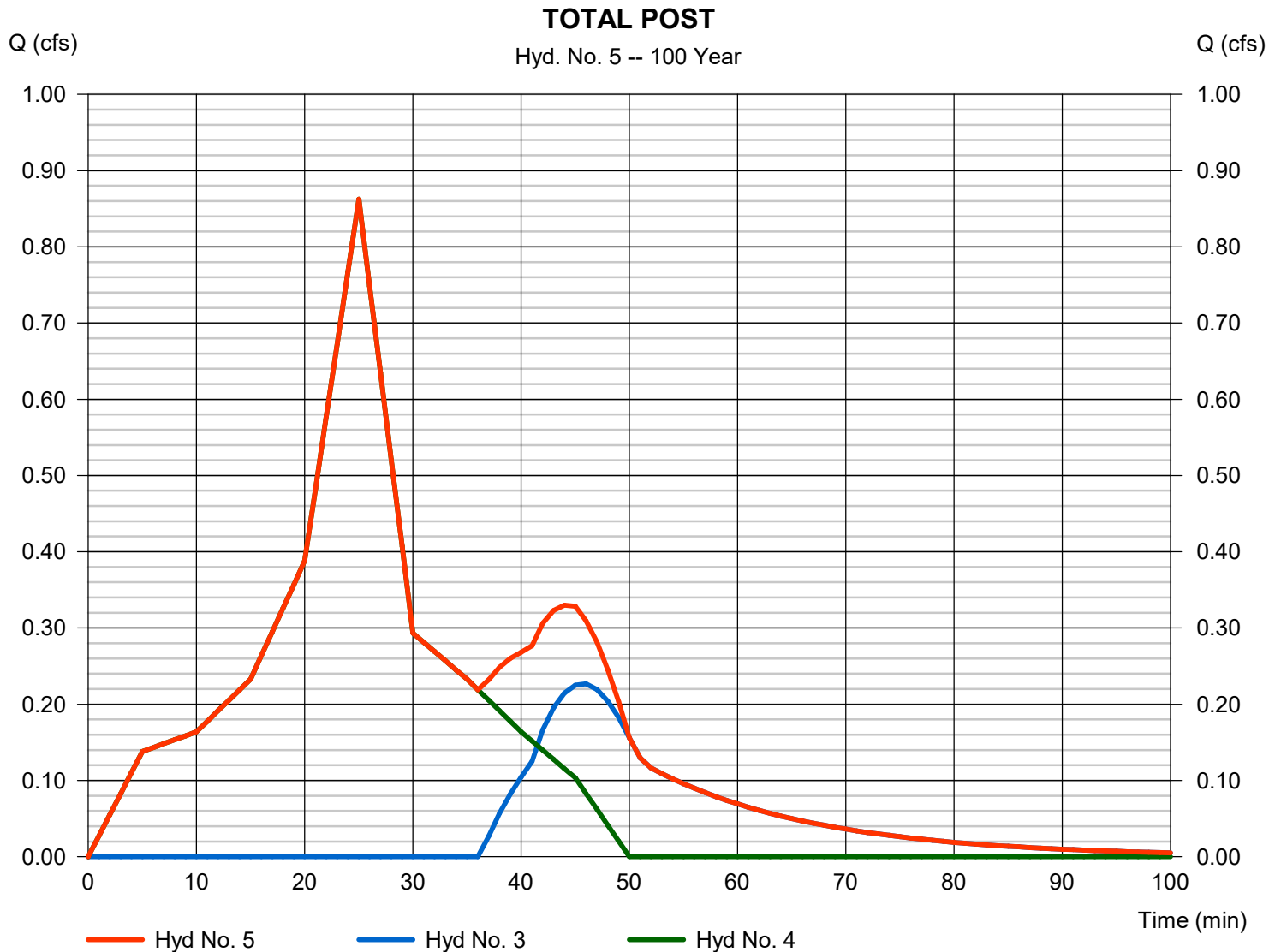

3.5 Stormwater Peak Rate Control Summary:

The following is a chart showing the rate reduction for each design storm as calculated in Hydraflow,

Post Development Design Storm	Total Runoff for Post Development conditions (cfs)	Pre-Development Design Storm	Total Runoff for Pre-development conditions (cfs)	Summary (cfs)
1-year	0.421	1-year	0.492	0.421<0.492
2-year	0.484	2-year	0.566	0.484<0.566
5-year	0.568	5-year	0.664	0.568<0.664
10-year	0.634	10-year	0.741	0.634<0.741
25-year	0.706	25-year	0.825	0.706<0.825
50-year	0.790	50-year	0.924	0.790<0.924
100-year	0.862	100-year	1.008	0.862<1.008

4.0 APPENDICES



United States
Department of
Agriculture

NRCS

Natural
Resources
Conservation
Service

A product of the National
Cooperative Soil Survey,
a joint effort of the United
States Department of
Agriculture and other
Federal agencies, State
agencies including the
Agricultural Experiment
Stations, and local
participants

Custom Soil Resource Report for Montgomery County, Pennsylvania



Preface

Soil surveys contain information that affects land use planning in survey areas. They highlight soil limitations that affect various land uses and provide information about the properties of the soils in the survey areas. Soil surveys are designed for many different users, including farmers, ranchers, foresters, agronomists, urban planners, community officials, engineers, developers, builders, and home buyers. Also, conservationists, teachers, students, and specialists in recreation, waste disposal, and pollution control can use the surveys to help them understand, protect, or enhance the environment.

Various land use regulations of Federal, State, and local governments may impose special restrictions on land use or land treatment. Soil surveys identify soil properties that are used in making various land use or land treatment decisions. The information is intended to help the land users identify and reduce the effects of soil limitations on various land uses. The landowner or user is responsible for identifying and complying with existing laws and regulations.

Although soil survey information can be used for general farm, local, and wider area planning, onsite investigation is needed to supplement this information in some cases. Examples include soil quality assessments (<http://www.nrcs.usda.gov/wps/portal/nrcs/main/soils/health/>) and certain conservation and engineering applications. For more detailed information, contact your local USDA Service Center (<https://offices.sc.egov.usda.gov/locator/app?agency=nrcs>) or your NRCS State Soil Scientist (http://www.nrcs.usda.gov/wps/portal/nrcs/detail/soils/contactus/?cid=nrcs142p2_053951).

Great differences in soil properties can occur within short distances. Some soils are seasonally wet or subject to flooding. Some are too unstable to be used as a foundation for buildings or roads. Clayey or wet soils are poorly suited to use as septic tank absorption fields. A high water table makes a soil poorly suited to basements or underground installations.

The National Cooperative Soil Survey is a joint effort of the United States Department of Agriculture and other Federal agencies, State agencies including the Agricultural Experiment Stations, and local agencies. The Natural Resources Conservation Service (NRCS) has leadership for the Federal part of the National Cooperative Soil Survey.

Information about soils is updated periodically. Updated information is available through the NRCS Web Soil Survey, the site for official soil survey information.

The U.S. Department of Agriculture (USDA) prohibits discrimination in all its programs and activities on the basis of race, color, national origin, age, disability, and where applicable, sex, marital status, familial status, parental status, religion, sexual orientation, genetic information, political beliefs, reprisal, or because all or a part of an individual's income is derived from any public assistance program. (Not all prohibited bases apply to all programs.) Persons with disabilities who require

alternative means for communication of program information (Braille, large print, audiotape, etc.) should contact USDA's TARGET Center at (202) 720-2600 (voice and TDD). To file a complaint of discrimination, write to USDA, Director, Office of Civil Rights, 1400 Independence Avenue, S.W., Washington, D.C. 20250-9410 or call (800) 795-3272 (voice) or (202) 720-6382 (TDD). USDA is an equal opportunity provider and employer.

Contents

Preface	2
How Soil Surveys Are Made	5
Soil Map	8
Soil Map (Soil Map).....	9
Legend.....	10
Map Unit Legend (Soil Map).....	11
Map Unit Descriptions (Soil Map).....	11
Montgomery County, Pennsylvania.....	13
UgB—Urban land, 0 to 8 percent slopes.....	13
UgD—Urban land, 8 to 25 percent slopes.....	13
UudB—Urban land-Udorthents, limestone complex, 0 to 8 percent slopes.....	14
UugD—Urban land-Udorthents, schist and gneiss complex, 8 to 25 percent slopes.....	16
References	19

How Soil Surveys Are Made

Soil surveys are made to provide information about the soils and miscellaneous areas in a specific area. They include a description of the soils and miscellaneous areas and their location on the landscape and tables that show soil properties and limitations affecting various uses. Soil scientists observed the steepness, length, and shape of the slopes; the general pattern of drainage; the kinds of crops and native plants; and the kinds of bedrock. They observed and described many soil profiles. A soil profile is the sequence of natural layers, or horizons, in a soil. The profile extends from the surface down into the unconsolidated material in which the soil formed or from the surface down to bedrock. The unconsolidated material is devoid of roots and other living organisms and has not been changed by other biological activity.

Currently, soils are mapped according to the boundaries of major land resource areas (MLRAs). MLRAs are geographically associated land resource units that share common characteristics related to physiography, geology, climate, water resources, soils, biological resources, and land uses (USDA, 2006). Soil survey areas typically consist of parts of one or more MLRA.

The soils and miscellaneous areas in a survey area occur in an orderly pattern that is related to the geology, landforms, relief, climate, and natural vegetation of the area. Each kind of soil and miscellaneous area is associated with a particular kind of landform or with a segment of the landform. By observing the soils and miscellaneous areas in the survey area and relating their position to specific segments of the landform, a soil scientist develops a concept, or model, of how they were formed. Thus, during mapping, this model enables the soil scientist to predict with a considerable degree of accuracy the kind of soil or miscellaneous area at a specific location on the landscape.

Commonly, individual soils on the landscape merge into one another as their characteristics gradually change. To construct an accurate soil map, however, soil scientists must determine the boundaries between the soils. They can observe only a limited number of soil profiles. Nevertheless, these observations, supplemented by an understanding of the soil-vegetation-landscape relationship, are sufficient to verify predictions of the kinds of soil in an area and to determine the boundaries.

Soil scientists recorded the characteristics of the soil profiles that they studied. They noted soil color, texture, size and shape of soil aggregates, kind and amount of rock fragments, distribution of plant roots, reaction, and other features that enable them to identify soils. After describing the soils in the survey area and determining their properties, the soil scientists assigned the soils to taxonomic classes (units). Taxonomic classes are concepts. Each taxonomic class has a set of soil characteristics with precisely defined limits. The classes are used as a basis for comparison to classify soils systematically. Soil taxonomy, the system of taxonomic classification used in the United States, is based mainly on the kind and character of soil properties and the arrangement of horizons within the profile. After the soil

Custom Soil Resource Report

scientists classified and named the soils in the survey area, they compared the individual soils with similar soils in the same taxonomic class in other areas so that they could confirm data and assemble additional data based on experience and research.

The objective of soil mapping is not to delineate pure map unit components; the objective is to separate the landscape into landforms or landform segments that have similar use and management requirements. Each map unit is defined by a unique combination of soil components and/or miscellaneous areas in predictable proportions. Some components may be highly contrasting to the other components of the map unit. The presence of minor components in a map unit in no way diminishes the usefulness or accuracy of the data. The delineation of such landforms and landform segments on the map provides sufficient information for the development of resource plans. If intensive use of small areas is planned, onsite investigation is needed to define and locate the soils and miscellaneous areas.

Soil scientists make many field observations in the process of producing a soil map. The frequency of observation is dependent upon several factors, including scale of mapping, intensity of mapping, design of map units, complexity of the landscape, and experience of the soil scientist. Observations are made to test and refine the soil-landscape model and predictions and to verify the classification of the soils at specific locations. Once the soil-landscape model is refined, a significantly smaller number of measurements of individual soil properties are made and recorded. These measurements may include field measurements, such as those for color, depth to bedrock, and texture, and laboratory measurements, such as those for content of sand, silt, clay, salt, and other components. Properties of each soil typically vary from one point to another across the landscape.

Observations for map unit components are aggregated to develop ranges of characteristics for the components. The aggregated values are presented. Direct measurements do not exist for every property presented for every map unit component. Values for some properties are estimated from combinations of other properties.

While a soil survey is in progress, samples of some of the soils in the area generally are collected for laboratory analyses and for engineering tests. Soil scientists interpret the data from these analyses and tests as well as the field-observed characteristics and the soil properties to determine the expected behavior of the soils under different uses. Interpretations for all of the soils are field tested through observation of the soils in different uses and under different levels of management. Some interpretations are modified to fit local conditions, and some new interpretations are developed to meet local needs. Data are assembled from other sources, such as research information, production records, and field experience of specialists. For example, data on crop yields under defined levels of management are assembled from farm records and from field or plot experiments on the same kinds of soil.

Predictions about soil behavior are based not only on soil properties but also on such variables as climate and biological activity. Soil conditions are predictable over long periods of time, but they are not predictable from year to year. For example, soil scientists can predict with a fairly high degree of accuracy that a given soil will have a high water table within certain depths in most years, but they cannot predict that a high water table will always be at a specific level in the soil on a specific date.

After soil scientists located and identified the significant natural bodies of soil in the survey area, they drew the boundaries of these bodies on aerial photographs and

Custom Soil Resource Report

identified each as a specific map unit. Aerial photographs show trees, buildings, fields, roads, and rivers, all of which help in locating boundaries accurately.

Soil Map

The soil map section includes the soil map for the defined area of interest, a list of soil map units on the map and extent of each map unit, and cartographic symbols displayed on the map. Also presented are various metadata about data used to produce the map, and a description of each soil map unit.

Custom Soil Resource Report Soil Map (Soil Map)



Map Scale: 1:1,010 if printed on A landscape (11" x 8.5") sheet.

0 10 20 40 60 Meters

0 45 90 180 270 Feet

Map projection: Web Mercator Corner coordinates: WGS84 Edge tics: UTM Zone 18N WGS84



MAP LEGEND

Area of Interest (AOI)

 Area of Interest (AOI)

Soils

 Soil Map Unit Polygons

 Soil Map Unit Lines

 Soil Map Unit Points

Special Point Features

 Blowout

 Borrow Pit

 Clay Spot

 Closed Depression

 Gravel Pit

 Gravelly Spot

 Landfill

 Lava Flow

 Marsh or swamp

 Mine or Quarry

 Miscellaneous Water

 Perennial Water

 Rock Outcrop

 Saline Spot

 Sandy Spot

 Severely Eroded Spot

 Sinkhole

 Slide or Slip

 Sodic Spot

 Spoil Area

 Stony Spot

 Very Stony Spot

 Wet Spot

 Other

 Special Line Features

Water Features

 Streams and Canals

Transportation

 Rails

 Interstate Highways

 US Routes

 Major Roads

 Local Roads

Background

 Aerial Photography

MAP INFORMATION

The soil surveys that comprise your AOI were mapped at 1:12,000.

Warning: Soil Map may not be valid at this scale.

Enlargement of maps beyond the scale of mapping can cause misunderstanding of the detail of mapping and accuracy of soil line placement. The maps do not show the small areas of contrasting soils that could have been shown at a more detailed scale.

Please rely on the bar scale on each map sheet for map measurements.

Source of Map: Natural Resources Conservation Service
 Web Soil Survey URL:
 Coordinate System: Web Mercator (EPSG:3857)

Maps from the Web Soil Survey are based on the Web Mercator projection, which preserves direction and shape but distorts distance and area. A projection that preserves area, such as the Albers equal-area conic projection, should be used if more accurate calculations of distance or area are required.

This product is generated from the USDA-NRCS certified data as of the version date(s) listed below.

Soil Survey Area: Montgomery County, Pennsylvania
 Survey Area Data: Version 15, Jun 5, 2020

Soil map units are labeled (as space allows) for map scales 1:50,000 or larger.

Date(s) aerial images were photographed: Jul 25, 2014—Aug 11, 2014

The orthophoto or other base map on which the soil lines were compiled and digitized probably differs from the background imagery displayed on these maps. As a result, some minor shifting of map unit boundaries may be evident.

Map Unit Legend (Soil Map)

Map Unit Symbol	Map Unit Name	Acres in AOI	Percent of AOI
UgB	Urban land, 0 to 8 percent slopes	4.5	86.9%
UgD	Urban land, 8 to 25 percent slopes	0.0	0.2%
UudB	Urban land-Udorthents, limestone complex, 0 to 8 percent slopes	0.3	5.7%
UugD	Urban land-Udorthents, schist and gneiss complex, 8 to 25 percent slopes	0.4	7.2%
Totals for Area of Interest		5.1	100.0%

Map Unit Descriptions (Soil Map)

The map units delineated on the detailed soil maps in a soil survey represent the soils or miscellaneous areas in the survey area. The map unit descriptions, along with the maps, can be used to determine the composition and properties of a unit.

A map unit delineation on a soil map represents an area dominated by one or more major kinds of soil or miscellaneous areas. A map unit is identified and named according to the taxonomic classification of the dominant soils. Within a taxonomic class there are precisely defined limits for the properties of the soils. On the landscape, however, the soils are natural phenomena, and they have the characteristic variability of all natural phenomena. Thus, the range of some observed properties may extend beyond the limits defined for a taxonomic class. Areas of soils of a single taxonomic class rarely, if ever, can be mapped without including areas of other taxonomic classes. Consequently, every map unit is made up of the soils or miscellaneous areas for which it is named and some minor components that belong to taxonomic classes other than those of the major soils.

Most minor soils have properties similar to those of the dominant soil or soils in the map unit, and thus they do not affect use and management. These are called noncontrasting, or similar, components. They may or may not be mentioned in a particular map unit description. Other minor components, however, have properties and behavioral characteristics divergent enough to affect use or to require different management. These are called contrasting, or dissimilar, components. They generally are in small areas and could not be mapped separately because of the scale used. Some small areas of strongly contrasting soils or miscellaneous areas are identified by a special symbol on the maps. If included in the database for a given area, the contrasting minor components are identified in the map unit descriptions along with some characteristics of each. A few areas of minor components may not have been observed, and consequently they are not mentioned in the descriptions, especially where the pattern was so complex that it was impractical to make enough observations to identify all the soils and miscellaneous areas on the landscape.

Custom Soil Resource Report

The presence of minor components in a map unit in no way diminishes the usefulness or accuracy of the data. The objective of mapping is not to delineate pure taxonomic classes but rather to separate the landscape into landforms or landform segments that have similar use and management requirements. The delineation of such segments on the map provides sufficient information for the development of resource plans. If intensive use of small areas is planned, however, onsite investigation is needed to define and locate the soils and miscellaneous areas.

An identifying symbol precedes the map unit name in the map unit descriptions. Each description includes general facts about the unit and gives important soil properties and qualities.

Soils that have profiles that are almost alike make up a *soil series*. Except for differences in texture of the surface layer, all the soils of a series have major horizons that are similar in composition, thickness, and arrangement.

Soils of one series can differ in texture of the surface layer, slope, stoniness, salinity, degree of erosion, and other characteristics that affect their use. On the basis of such differences, a soil series is divided into *soil phases*. Most of the areas shown on the detailed soil maps are phases of soil series. The name of a soil phase commonly indicates a feature that affects use or management. For example, Alpha silt loam, 0 to 2 percent slopes, is a phase of the Alpha series.

Some map units are made up of two or more major soils or miscellaneous areas. These map units are complexes, associations, or undifferentiated groups.

A *complex* consists of two or more soils or miscellaneous areas in such an intricate pattern or in such small areas that they cannot be shown separately on the maps. The pattern and proportion of the soils or miscellaneous areas are somewhat similar in all areas. Alpha-Beta complex, 0 to 6 percent slopes, is an example.

An *association* is made up of two or more geographically associated soils or miscellaneous areas that are shown as one unit on the maps. Because of present or anticipated uses of the map units in the survey area, it was not considered practical or necessary to map the soils or miscellaneous areas separately. The pattern and relative proportion of the soils or miscellaneous areas are somewhat similar. Alpha-Beta association, 0 to 2 percent slopes, is an example.

An *undifferentiated group* is made up of two or more soils or miscellaneous areas that could be mapped individually but are mapped as one unit because similar interpretations can be made for use and management. The pattern and proportion of the soils or miscellaneous areas in a mapped area are not uniform. An area can be made up of only one of the major soils or miscellaneous areas, or it can be made up of all of them. Alpha and Beta soils, 0 to 2 percent slopes, is an example.

Some surveys include *miscellaneous areas*. Such areas have little or no soil material and support little or no vegetation. Rock outcrop is an example.

Montgomery County, Pennsylvania

UgB—Urban land, 0 to 8 percent slopes

Map Unit Setting

National map unit symbol: 2dtyq
Elevation: 800 to 1,500 feet
Mean annual precipitation: 36 to 46 inches
Mean annual air temperature: 41 to 62 degrees F
Frost-free period: 130 to 170 days
Farmland classification: Not prime farmland

Map Unit Composition

Urban land: 90 percent
Minor components: 10 percent
Estimates are based on observations, descriptions, and transects of the mapunit.

Description of Urban Land

Setting

Parent material: Pavement, buildings and other artificially covered areas human transported material

Interpretive groups

Land capability classification (irrigated): None specified
Land capability classification (nonirrigated): 8s
Hydric soil rating: No

Minor Components

Udorthents, unstable fill

Percent of map unit: 10 percent
Down-slope shape: Linear
Across-slope shape: Linear
Hydric soil rating: No

UgD—Urban land, 8 to 25 percent slopes

Map Unit Setting

National map unit symbol: 2dtyr
Elevation: 800 to 1,500 feet
Mean annual precipitation: 36 to 46 inches
Mean annual air temperature: 41 to 62 degrees F
Frost-free period: 130 to 180 days
Farmland classification: Not prime farmland

Map Unit Composition

Urban land: 90 percent
Minor components: 10 percent
Estimates are based on observations, descriptions, and transects of the mapunit.

Description of Urban Land

Setting

Parent material: Pavement, buildings and areas covered with human-transported material

Interpretive groups

Land capability classification (irrigated): None specified

Land capability classification (nonirrigated): 8s

Hydric soil rating: No

Minor Components

Udorthents, unstable fill

Percent of map unit: 10 percent

Down-slope shape: Linear

Across-slope shape: Linear

Hydric soil rating: No

UudB—Urban land-Udorthents, limestone complex, 0 to 8 percent slopes

Map Unit Setting

National map unit symbol: 2dtz5

Elevation: 300 to 1,000 feet

Mean annual precipitation: 36 to 50 inches

Mean annual air temperature: 46 to 57 degrees F

Frost-free period: 140 to 200 days

Farmland classification: Not prime farmland

Map Unit Composition

Urban land: 80 percent

Udorthents, limestone, and similar soils: 15 percent

Minor components: 5 percent

Estimates are based on observations, descriptions, and transects of the mapunit.

Description of Urban Land

Setting

Landform: Hills, valleys

Landform position (two-dimensional): Summit, shoulder, backslope, footslope

Landform position (three-dimensional): Interfluve, side slope, nose slope, head slope

Down-slope shape: Linear, convex

Across-slope shape: Convex, linear

Parent material: Pavement, buildings and other artificially covered areas

Typical profile

H1 - 0 to 6 inches: variable

Custom Soil Resource Report

Properties and qualities

Slope: 0 to 8 percent

Depth to restrictive feature: 10 to 99 inches to lithic bedrock

Available water capacity: Very low (about 0.0 inches)

Interpretive groups

Land capability classification (irrigated): None specified

Land capability classification (nonirrigated): 8s

Hydric soil rating: No

Description of Udorthents, Limestone

Setting

Landform: Valleys, hills

Landform position (two-dimensional): Shoulder, footslope, backslope, summit

Landform position (three-dimensional): Interfluve, side slope, nose slope, head slope

Down-slope shape: Linear, convex

Across-slope shape: Convex, linear

Parent material: Graded areas of argillaceous limestone

Typical profile

H1 - 0 to 6 inches: clay loam

H2 - 6 to 60 inches: clay

Properties and qualities

Slope: 0 to 8 percent

Depth to restrictive feature: 20 to 99 inches to lithic bedrock

Drainage class: Moderately well drained

Runoff class: Very high

Capacity of the most limiting layer to transmit water (Ksat): Moderately low to moderately high (0.06 to 0.20 in/hr)

Depth to water table: About 6 to 24 inches

Frequency of flooding: None

Frequency of ponding: None

Available water capacity: High (about 10.2 inches)

Interpretive groups

Land capability classification (irrigated): None specified

Land capability classification (nonirrigated): 7s

Hydrologic Soil Group: C/D

Hydric soil rating: No

Minor Components

Duffield

Percent of map unit: 5 percent

Landform: Hills

Landform position (two-dimensional): Summit

Landform position (three-dimensional): Interfluve

Down-slope shape: Linear

Across-slope shape: Linear

Hydric soil rating: No

UugD—Urban land-Udorthents, schist and gneiss complex, 8 to 25 percent slopes

Map Unit Setting

National map unit symbol: 2dtz8
Elevation: 200 to 2,000 feet
Mean annual precipitation: 35 to 55 inches
Mean annual air temperature: 45 to 61 degrees F
Frost-free period: 110 to 235 days
Farmland classification: Not prime farmland

Map Unit Composition

Urban land: 80 percent
Udorthents, schist and gneiss, and similar soils: 15 percent
Minor components: 5 percent
Estimates are based on observations, descriptions, and transects of the mapunit.

Description of Urban Land

Setting

Landform: Hills
Landform position (two-dimensional): Summit, shoulder, backslope
Landform position (three-dimensional): Interfluve, side slope, nose slope
Down-slope shape: Linear, convex
Across-slope shape: Convex, linear
Parent material: Pavement, buildings and other artificially covered areas

Typical profile

C - 0 to 6 inches: variable

Properties and qualities

Slope: 8 to 25 percent
Depth to restrictive feature: 10 to 99 inches to lithic bedrock
Available water capacity: Very low (about 0.0 inches)

Interpretive groups

Land capability classification (irrigated): None specified
Land capability classification (nonirrigated): 8s
Hydric soil rating: No

Description of Udorthents, Schist And Gneiss

Setting

Landform: Hills
Landform position (two-dimensional): Summit, shoulder, backslope
Landform position (three-dimensional): Interfluve, side slope, nose slope
Down-slope shape: Linear, convex
Across-slope shape: Convex, linear
Parent material: Graded areas of schist and/or gneiss

Custom Soil Resource Report

Typical profile

Ap - 0 to 6 inches: loam
C - 6 to 40 inches: silty clay loam
R - 40 to 60 inches: bedrock

Properties and qualities

Slope: 8 to 25 percent
Depth to restrictive feature: 20 to 70 inches to paralithic bedrock
Drainage class: Well drained
Runoff class: High
Capacity of the most limiting layer to transmit water (Ksat): Moderately low to moderately high (0.06 to 0.20 in/hr)
Depth to water table: About 60 inches
Frequency of flooding: None
Frequency of ponding: None
Available water capacity: Moderate (about 6.8 inches)

Interpretive groups

Land capability classification (irrigated): None specified
Land capability classification (nonirrigated): 7e
Hydrologic Soil Group: C
Hydric soil rating: No

Minor Components

Glenville

Percent of map unit: 1 percent
Landform: Hillslopes
Landform position (two-dimensional): Footslope, backslope
Landform position (three-dimensional): Side slope, head slope
Down-slope shape: Linear, concave
Across-slope shape: Concave, linear
Hydric soil rating: No

Baile

Percent of map unit: 1 percent
Landform: Depressions
Landform position (two-dimensional): Footslope
Landform position (three-dimensional): Base slope
Down-slope shape: Concave, linear
Across-slope shape: Concave, linear
Hydric soil rating: Yes

Edgemont

Percent of map unit: 1 percent
Landform: Ridges
Landform position (two-dimensional): Summit
Landform position (three-dimensional): Mountaintop
Down-slope shape: Convex, linear
Across-slope shape: Linear, convex
Hydric soil rating: No

Gladstone

Percent of map unit: 1 percent
Landform: Hillslopes
Landform position (two-dimensional): Summit, shoulder
Landform position (three-dimensional): Nose slope, side slope

Custom Soil Resource Report

Down-slope shape: Linear, convex
Across-slope shape: Linear, convex
Hydric soil rating: No

Glenelg

Percent of map unit: 1 percent
Landform: Hillslopes
Landform position (two-dimensional): Summit, shoulder, backslope
Landform position (three-dimensional): Interfluve, side slope, nose slope
Down-slope shape: Linear, convex
Across-slope shape: Convex, linear
Hydric soil rating: No

References

- American Association of State Highway and Transportation Officials (AASHTO). 2004. Standard specifications for transportation materials and methods of sampling and testing. 24th edition.
- American Society for Testing and Materials (ASTM). 2005. Standard classification of soils for engineering purposes. ASTM Standard D2487-00.
- Cowardin, L.M., V. Carter, F.C. Golet, and E.T. LaRoe. 1979. Classification of wetlands and deep-water habitats of the United States. U.S. Fish and Wildlife Service FWS/OBS-79/31.
- Federal Register. July 13, 1994. Changes in hydric soils of the United States.
- Federal Register. September 18, 2002. Hydric soils of the United States.
- Hurt, G.W., and L.M. Vasilas, editors. Version 6.0, 2006. Field indicators of hydric soils in the United States.
- National Research Council. 1995. Wetlands: Characteristics and boundaries.
- Soil Survey Division Staff. 1993. Soil survey manual. Soil Conservation Service. U.S. Department of Agriculture Handbook 18. http://www.nrcs.usda.gov/wps/portal/nrcs/detail/national/soils/?cid=nrcs142p2_054262
- Soil Survey Staff. 1999. Soil taxonomy: A basic system of soil classification for making and interpreting soil surveys. 2nd edition. Natural Resources Conservation Service, U.S. Department of Agriculture Handbook 436. http://www.nrcs.usda.gov/wps/portal/nrcs/detail/national/soils/?cid=nrcs142p2_053577
- Soil Survey Staff. 2010. Keys to soil taxonomy. 11th edition. U.S. Department of Agriculture, Natural Resources Conservation Service. http://www.nrcs.usda.gov/wps/portal/nrcs/detail/national/soils/?cid=nrcs142p2_053580
- Tiner, R.W., Jr. 1985. Wetlands of Delaware. U.S. Fish and Wildlife Service and Delaware Department of Natural Resources and Environmental Control, Wetlands Section.
- United States Army Corps of Engineers, Environmental Laboratory. 1987. Corps of Engineers wetlands delineation manual. Waterways Experiment Station Technical Report Y-87-1.
- United States Department of Agriculture, Natural Resources Conservation Service. National forestry manual. http://www.nrcs.usda.gov/wps/portal/nrcs/detail/soils/home/?cid=nrcs142p2_053374
- United States Department of Agriculture, Natural Resources Conservation Service. National range and pasture handbook. <http://www.nrcs.usda.gov/wps/portal/nrcs/detail/national/landuse/rangepasture/?cid=stelprdb1043084>

Custom Soil Resource Report

United States Department of Agriculture, Natural Resources Conservation Service. National soil survey handbook, title 430-VI. http://www.nrcs.usda.gov/wps/portal/nrcs/detail/soils/scientists/?cid=nrcs142p2_054242

United States Department of Agriculture, Natural Resources Conservation Service. 2006. Land resource regions and major land resource areas of the United States, the Caribbean, and the Pacific Basin. U.S. Department of Agriculture Handbook 296. http://www.nrcs.usda.gov/wps/portal/nrcs/detail/national/soils/?cid=nrcs142p2_053624

United States Department of Agriculture, Soil Conservation Service. 1961. Land capability classification. U.S. Department of Agriculture Handbook 210. http://www.nrcs.usda.gov/Internet/FSE_DOCUMENTS/nrcs142p2_052290.pdf

WHITEMARSH TOWNSHIP

To: Charlie L. Guttenplan, Director of Planning & Zoning/Zoning Officer
From: NICHOLAS W. WEAVER, FIRE MARSHAL 
Subject: SLD #01-22 931 Spring Mill Avenue, LLC 927-31 Spring Mill Ave
Date: January 10, 2022
cc:

This application cannot be approved at this time for the following outstanding items:

1. All buildings must have a fire hydrant within 400' of the structure by approved route. The applicant must provide a plan showing the distances to the nearest fire hydrants.
 - a. If the building is sprinklered, then the distance is increased to 600'.

Nicholas W. Weaver
Fire Marshal
616 Germantown Pike
Lafayette Hill, PA 19444
Phone: 610-825-3535 ext. 2614
Email: nweaver@whitemarshtwp.org

UPDATES

**MONTGOMERY COUNTY
BOARD OF COMMISSIONERS**

VALERIE A. ARKOOSH, MD, MPH, CHAIR
KENNETH E. LAWRENCE, JR., VICE CHAIR
JOSEPH C. GALE, COMMISSIONER



**MONTGOMERY COUNTY
PLANNING COMMISSION**

MONTGOMERY COUNTY COURTHOUSE • PO BOX 311
NORRISTOWN, PA 19404-0311
610-278-3722
FAX: 610-278-3941 • TDD: 610-631-1211
WWW.MONTCOPA.ORG

SCOTT FRANCE, AICP
EXECUTIVE DIRECTOR

February 3, 2022

Mr. Charles L. Guttenplan, AICP
Director of Planning & Zoning Officer
Whitemarsh Township
616 Germantown Pike
Lafayette Hill, Pennsylvania 19444

Re: MCPC #22-0009-001
Plan Name: WESTY Project
20 dwelling units/17,950 gross sq. ft. /0.40 acres
Situate: Spring Mill Avenue (south)/ Lime Street (west)
Whitemarsh Township / Borough of Conshohocken

Dear Mr. Guttenplan:

We have reviewed the above-referenced subdivision proposal in accordance with Section 502 of Act 247, "The Pennsylvania Municipalities Planning Code," as you requested on January 12, 2022. We forward this letter as a report of our review.

BACKGROUND

The applicant, 931 Spring Mill Avenue, LLC has submitted for review a land development plan seeking preliminary plan approval proposing the redevelopment of a 0.40 acre tract into a 20-unit multi-family residential building. The site is currently vacant and was once a tire shop which appears to be abandoned. The parcels are situated in the township's C-Residential District and in the Riverfront Development District Overlay (RDD), Sub-District 2 (RDD-2).

The development tract is comprised of 4 tax parcels which are located at 927 and 931 Spring Mill Avenue on the southwest corner of the intersection at Lime Street. The existing lots contain a single family attached dwelling, and a vacant one-story commercial building with existing access and driveways from both roadways. The applicant proposes the demolition of the building and the twin structure will be retained in the new lot consolidation.



CONSISTENCY WITH THE COUNTY COMPREHENSIVE PLAN

Consistency with *Montco 2040- A Shared Vision*

The redevelopment proposal for this site is consistent with the future land use vision and stated goals of *Montco 2040: A Shared Vision*, the comprehensive plan and future land use vision for the county. The Future Land Use Map of the plan designates the land use vision for the site as “Town-Residential” and it is immediately west of the “Business-Area” that includes the Spring Mill Corporate Center. The goal is to promote a walkable residential neighborhood which includes single-family homes, townhouses and multi-family housing.

Consistency with the *Whitemarsh Township Plan Update, 2020*

The redevelopment proposal for this property appears compatible with the township’s future land use vision for this area as a “Mixed-Use Node” Character Area, as recommended in the *Whitemarsh Township Selective Comprehensive Plan Update, 2020*, and specifically in the plans detailed in Chapter Four- Future Land Use Plan. The future land use goal for this character area is to support mixed-use development with public spaces and associated amenities.

RECOMMENDATION

The Montgomery County Planning Commission (MCPC) supports the redevelopment of the applicant’s site as an apartment building, however, in the course of our review we have identified several issues that we recommend the township address in its assessment of the project. These issues include: the need for a pedestrian-friendly streetscape design; the adequacy and functionality of the proposed sub-surface parking lot; and needed improvements in the applicant’s landscape plan.

COMMENTS

1. Off-Street Parking

a. Functionality of the sub-surface parking arrangement.

The plan proposes a number of parking spaces in which the functionality and maneuverability of vehicular parking is questionable. The plan shows a number of parking spaces (shown as #26- #35) under the building and immediately adjacent to building’s exterior wall that appear to be double-stacked with the opposite parking spaces (#17-25), which would prevent access. It is not clear from the applicant’s submitted plans whether cars are designed to enter directly to these spaces (#26- #35) from the paved area along the property’s southern boundary. The applicant should clarify how these spaces are designed to function effectively and safely, and we recommend the applicant provide the township with an architectural elevation of the south façade. Also, several parking spaces, (#1-#4) shown outside the sub-surface structure and adjacent to a retaining wall appear to have a blind spot and limited viewing for drivers backing out into the drive aisle. The applicant should provide architectural and structural details on how these spaces will function. These issues are highlighted below in the annotated graphic.

b. *Americans with Disabilities Act (“ADA”) parking spaces.*

The applicant’s parking lot arrangement does not adequately address the township’s Off-Street Parking requirements as it does not include “ADA” parking spaces required by Section 116-184.A. According to the Zoning Code, the applicant should provide the applicable number of “ADA” spaces based upon the requirements set forth in the latest edition of the International Building Code and its associated ANSI Standards.

c. *Electric Vehicle Charging Stations Requirements.*

In addition to the required 35 parking spaces, the applicant should provide electrical vehicle (EV) charging stations in this development, as required by Section 116-188.3 Electric Vehicle Charging Stations. According to this requirement, it appears the plan should provide 2 EV stations in the off-street parking area. The township should ensure that the plan fully addresses all of the EV charging station requirements including the minimum number, the location, and the EV charging station signage.

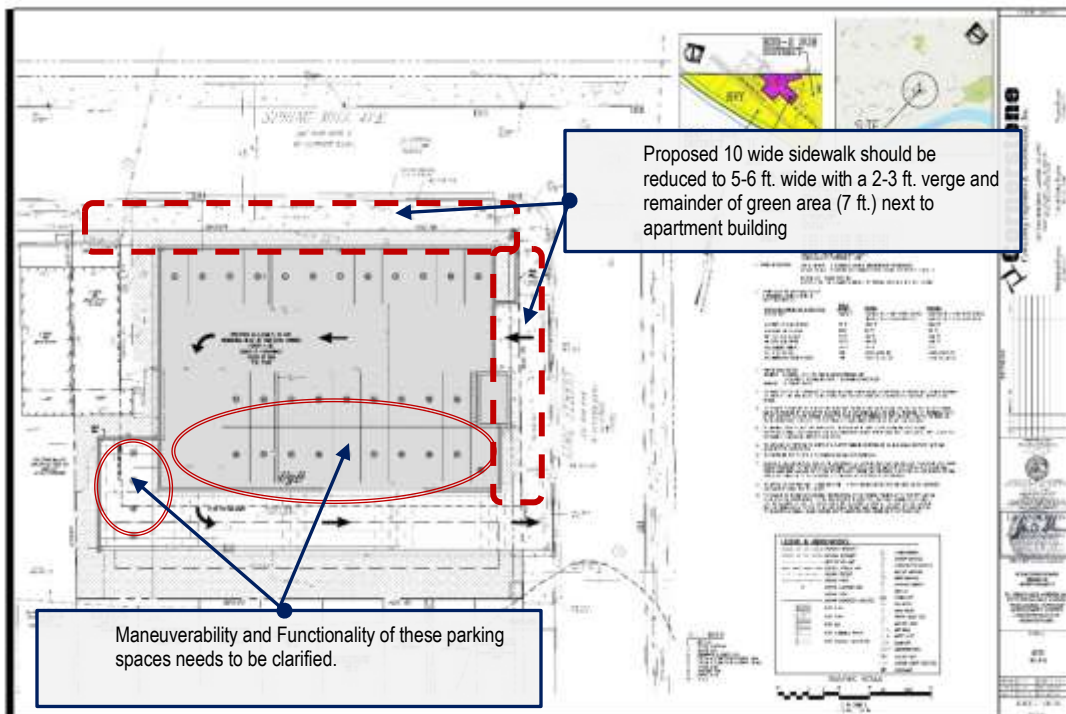

Issue of functionality of parking spaces & sidewalk width along the streets

2. **Streetscape Environment**

a. *Proposed sidewalk, verge and landscape area.*

The plan proposes 10 ft. wide sidewalks along both Spring Mill Avenue and Lime Street. We believe this extra wide sidewalk is not consistent with the existing Spring Mill streetscape profile. A wide expanse of sidewalk offers very limited space for adequate greening along both streets that could ensure a more attractive pedestrian streetscape for the future. We recommend the applicant revise

the plan using a streetscape profile with a 2-3 ft. wide grass verge along with a 5 ft. wide sidewalk, and use the remaining 7-8 feet next to the building for greening improvements. We recommend using a similar streetscape improvement profile along Lime Street, rather than a 10 ft. wide sidewalk. We have attached a “StreetView” of the applicant’s Spring Mill Ave. frontage and the grass verge that exists in front of 927 Spring Mill Ave.



927 Spring Mill Avenue twin- extend the grass verge area.

b. Appropriate tree species along the building’s street frontage.

The applicant’s architectural elevation submission proposes an attractive apartment building with the needed street trees along the building’s Spring Mill Avenue façade. However, the proposed planting plan is not consistent with the rendering and does not show any street trees along the street frontages. We believe that street trees are a necessary greening improvement for this development in order to create an attractive, walkable environment along the building’s 3-story brick façade. The street frontage does have some limitations with its overhead transmission lines. We believe that the appropriate tree species could be accommodated within this restricted setting, and suggest the applicant consider the following species for this space: Sweetbay magnolia (*Magnolia virginiana*), and Fastigate European Hornbeam (*Carpinus betulus ‘Fastigata’*).

2. Landscape Plan

a. Opportunity for Canopy Trees along the rear-yard buffer area.

The lack of any shade tree species in the applicant’s landscape improvements plan is concerning; we suggest a missed opportunity to create the needed tree canopy in the rear of the lot. The plan proposes flowering trees- 3 dogwoods and 2 redbuds - as the only tree improvements for the site’s development. Larger shade tree species are needed and could be accommodated along the southern property boundary adjacent to the porous pavement area. This 140-ft. landscape buffer length could accommodate 4-5 large shade trees in combination with the proposed shrub plantings. A root barrier could be installed to redirect and prevent tree roots from expanding into the porous pavement area. We recommend the applicant include additional large shade tree species in this area for shading and environmental benefits.

b. Diversify the evergreen plantings along the rear buffer area.

The plan proposes the use of 17- *Thuja X 'Green Giant'* as the only evergreen tree species along the rear buffer area. The resiliency of landscape planting improvement along the buffer can ensure a greater diversity of evergreen species; therefore, we recommend the applicant diversify the evergreen component in the landscape by adding an additional evergreen tree species. This could include the American holly (*Ilex opaca*) or related holly hybrids such as *Ilex X 'Nellie R. Stevens'*. Other useful evergreens include the 'Yoshino' Japanese cedar (*Cryptomeria japonica 'Yoshino'*) and the Eastern red cedar (*Juniperus virginiana*).

CONCLUSION

We recommend the township address the above mentioned review comments to your satisfaction. Please note that the review comment and recommendation contained in this report are advisory to the municipality and final disposition for the approval of any proposal will be made by the municipality.

Please be aware that the MCPC #22-0009-001 has been set aside for the applicant' plan. If any subsequent plans are submitted for final recording, this MCPC number should appear on the applicant sheets within the plans in the box reserved for the seal of this agency.

Should the governing body approve a final plat of this proposal, the applicant must present the plan to our office for seal and signature prior to recording with the Recorder of Deeds office. A paper copy bearing the municipal seal and signature of approval must be supplied for our files.

Sincerely,

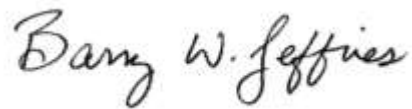

Barry W Jeffries, ASLA, Senior Design Planner
bjeffrie@montcopa.org - 610-278-3444

c: Aaron Kostyk, Chair, Whitemarsh Township Planning Commission
Krista Heinrich, Whitemarsh Township Engineer
David Sander, Esq., Whitemarsh Township Solicitor
Stephanie Cecco, Manager, Conshohocken Boro

Attachments: 1) Aerial; 2) Site Plan



WESTY Project
MCPC #220009001

Montgomery
County
Planning
Commission
Montgomery County Courthouse - Planning Commission
PO Box 371 • Norristown PA 19304-0371
(p) 610.278.3722 • (f) 610.278.3940
www.montcopa.org/planning
Aerial photography provided by Nozmap.





Whitemarsh TOWNSHIP

616 GERMANTOWN PIKE - LAFAYETTE HILL, PA 19444-1821
TEL: 610-825-3535 FAX: 610-825-9416
www.whitemarshwp.org

BOARD of SUPERVISORS

Laura Boyle Nester – Chair
Fran McCusker – Vice Chair
Vincent Manuele
Jacy Toll
Patrice Turenne

Richard L. Mellor, Jr.
Township Manager

February 3, 2022

931 Spring Mill Avenue, LLC
c/o Chuck Borkowski
1301 Fayette Street
Conshohocken, PA 19428

**RE: SLD#01-22 / 931 Spring Mill Avenue, LLC (WESTY Project), 927-31 Spring Mill Avenue
Preliminary Land Development – 20 Unit Apartment Building; Project known as ‘WESTY’
Zoning Ordinance Compliance Review Letter**

Dear Mr. Borkowski:

As requested, we have reviewed plans for the above referenced 10-Sheet Land Development Plan submission, prepared by Cornerstone Consulting Engineers & Architectural, Inc., dated December 30, 2021, with no noted revisions. For this letter, we have also reviewed a single architectural rendering. This proposal involves lots at 927 through 931 Spring Mill Avenue. A 20-unit apartment building is proposed with primarily sub-surface parking; a single-family attached dwelling unit on 927 Spring Mill Avenue (half of a twin dwelling) is also being retained and is part of this proposal. The following are the Zoning Ordinance issues identified with respect to this proposal.

1. §116-11. As defined by Subdivision and Land Development Ordinance Section 105-30, Spring Mill Avenue and Lime Street are Local Streets with ultimate rights-of-way of 56 feet. The plans currently show a 60 foot wide right-of-way for Spring Mill Avenue, which must be revised.
2. §116-14. The plans must be revised to show the Zoning District Boundary line(s) and label for the C-Residential Zoning District along the centerline of Spring Mill Avenue and Lime Street.
3. §116-21. On any lot, no structure shall be erected, altered or maintained which shall interfere with a free and unobstructed view at or near the intersection of any two roads. Given the location of the proposed apartment building, an obstructed view must be demonstrated at the intersection of Spring Mill Avenue and Lime Street. (Please see related Comment #8 in this letter.)
4. §116-22. This section of the ordinance requires a note to be added to the plan which states that the permanent removal of topsoil from land within the Township is prohibited.
5. §116-24.D.(3) All accessory uses and structures combined shall cover no more than 30% of the area of the required rear yard or in the case where the principal building is set

farther back than minimum depth of the required rear yard, no more than 30% of the area contained between the rear lot line and the rear principal building plane as defined herein. Please note that Section 116-24.B.(10) defines off-street parking as an accessory use; this has been legally interpreted to refer to the parking spaces and does not include access aisles.

6. §116-28.A.(2) The applicant shall furnish a letter from the appropriate authority indicating the availability and supply of water for the proposed project to the Zoning Officer.
7. §116-29. The applicant must obtain the approval of the Whitmarsh Township Authority with regard to the proposed sanitary sewer facilities.
8. §116-33.D. Structures shall not be located within the clear sight triangle of any intersecting streets, defined as the triangle bounded by any two intersecting street lines and a straight line drawn between points on each such line 50 feet from the intersection of said lines or extensions thereof, unless a clear and unobstructed view can be demonstrated to the Township's satisfaction. The proposed structure appears to be located within the required clear sight triangle; an unobstructed view must be demonstrated.
9. §116-169.B. No more than 30% of the total area of land having a grade of 15% to 25% and no more than 15% of the total area of land having a grade of 25% or more shall be regraded and/or stripped of vegetation. The plans must be revised in order to demonstrate compliance with the requirements of this section of the ordinance.
10. §116-184.G. All parking shall conform to the requirements of the Whitmarsh Township Fire Prevention Code as acted and amended. The applicant must obtain approval from the Whitmarsh Township Fire Marshal. (Please see Fire Marshal's review memo of January 10, 2022, enclosed.)
11. §116-187. The plans must be revised to include adequate space, if required, for off-street loading. The plans must be revised to indicate the proposed method of garbage collection and provisions must be made to provide for deliveries and moving trucks.
12. §116-188.3. Electric Vehicle (EV) charging stations shall be required for all new parking areas. Two electric vehicle charging stations are required for any parking facilities that contain at least 20 but not more than 50 off-street parking spaces. A minimum of 50% of all required EV charging stations shall be ADA-accessible.
13. §116-205.,
§116-208.,
§116-209.,
§116-210.,
§116-286. These sections of the ordinance describe signs which are permitted in the districts on which the subject property is located. The plans must be revised to include details for all proposed signs to be installed as part of the design, in order to demonstrate compliance with these sections of the ordinance. Alternatively, signs may be submitted through permit applications should the project be approved.
14. §116-281.B.(3) The Zoning Data Table must be revised to account for the existing twin brick building to remain.
15. §116-281.B.(3)(b) The Zoning Data Table must be revised to indicate the lot width along the Lime Street Frontage.
16. §116-281.B.(3)(h) The plans must be revised to include a tabulation of each impervious surface. Please note, the proposed porous pavers must be considered as an impervious surface as part of the calculation of impervious ground cover ratio. If the applicant chooses to modify the surface to one considered pervious, the Township Engineer

would need to confirm that it is, and the Fire Marshal must approve the surface to withstand the weight of fire equipment that could be used on this property. If the final impervious surface ratio exceeds 75%, a variance would be required.

17. §116-282.A. Parking structures shall have another permitted first floor use on any portion of the structure visible from any streets or suitable architectural treatment shall be provided.
18. §116-283., §116-287.B.(2) The applicant must submit more detailed architectural plans, including elevation views for the proposed buildings, in order to demonstrate compliance with the requirements of these sections of the ordinance. The architectural rendering submitted, while indicating potential compliance, is not sufficient for this purpose.
19. §116-283.A.(6) The plans must be revised in order to demonstrate that any ground-mounted exposed HVAC units or other utility equipment are screened from view. This shall be accomplished through the use of masonry walls and landscaping.
20. §116-283.C.(1) Street trees shall be planted in accordance with §105-48 of the Subdivision and Land Development Ordinance.
21. §116-283.C.(2)(b) In no case shall tree trunks or shrubs negatively impact required sight triangles. Clear sight triangles must be shown on the Landscape Plan and landscaping must be revised, if necessary. The Landscape Plan must be reviewed by the Shade Tree Commission for recommendation to the Board of Supervisors.
22. §116-283.D. The plans must be revised in order to demonstrate compliance with the pedestrian oriented development requirements contained in this section ordinance, such as lighting along street frontage, benches, trash receptacles, wide sidewalks and other pedestrian amenities.

Additional Comment:

23. When this subdivision is recorded, a Deed of Consolidation for all lots involved in this development, must be recorded simultaneously.

Should you have any questions, please do not hesitate to contact me.

Very truly yours,



Charles L. Guttenplan, AICP
Director of Planning and Zoning/Zoning Officer

Enclosed: Fire Marshal Memo dated January 10, 2022

cc: Richard L. Mellor, Jr., Township Manager
Sean Halbom, Township Assistant Manager
Robert A. Sztubinski, B.C.O., Director of Building and Codes
Nick Weaver, Fire Marshal
Sean P. Kilkenny, Esq., Township Solicitor
Krista Heinrich, P.E., Township Engineer
John B. Anderson, P.E., Cornerstone Consulting Engineers & Architectural, Inc.



February 4, 2022

File No. 2022-01163

Mr. Richard L. Mellor, Jr., Township Manager
Whitemarsh Township Municipal Building
616 Germantown Pike
Lafayette Hill, PA 19444

Reference: Preliminary/Final Plan Review
931 Spring Mill Avenue
Whitemarsh Township, Montgomery County, Pennsylvania
SLD #01-22

Dear Mr. Mellor:

As requested, we have reviewed plans for the above referenced 10-Sheet Land Development Plan submission, prepared by Cornerstone Consulting Engineers & Architectural, Inc., dated December 30, 2021, with no noted revisions. The following comments are offered for your consideration:

SUBDIVISION AND LAND DEVELOPMENT ORDINANCE

	<u>Section</u>	<u>Description</u>
1.	105-21(B)(1) (d)[1]	The Record Plans must be revised to show the Zoning District Boundary line(s) and label for the C-Residential Zoning District along the centerline of Spring Mill Avenue and Lime Street.
2.	105-21(B)(1) (e)[6]	The plans must be revised to provide an indication of the size of units (in bedrooms), if known.
3.	105-21(B)(1) (e)[6]	Sheet C02.1 must be revised to show boundaries of all adjoining properties, including names of landowners across Spring Mill Avenue and Lime Street.
4.	105-21(B)(1)(f)	The location map must be shown at a scale of 1"=800'.
5.	105-21(B)(1)(k), 105-21(B)(1)(o)	The plans must be revised to indicate the location of all existing, if any, and proposed monumentation, in accordance with the requirements of section 105-72(A).
6.	105-21(B)(1)(n)	The plans must be revised to show existing principal buildings (and their respective uses), and driveways on the adjacent peripheral strip; sewer lines, storm drains, culverts, bridges, utility easements, quarries, railroads, and other significant man-made features within 500 feet of and within the site, including properties across streets.

65 East Butler Avenue | Suite 100 | New Britain, PA 18901 | Phone: 215-345-4330 | Fax: 215-345-8606

<u>Section</u>	<u>Description</u>
7. 105-21(B)(2)(g)	The plans must be revised to show all Steep slopes.
8. 105-21(B)(3)	The plans must be revised to show all existing large trees over six inches caliper standing alone, and any other significant vegetation.
9. 105-21(B)(9)(c)[2]	The applicant is advised that the Township Planning Commission, at its discretion, may request the preparation of a traffic impact study for any land development.
10. 105-21(B)(10)(a)	The applicant shall submit a letter from the appropriate municipal authority indicating the availability of public sanitary sewer facilities.
11. 105-21(B)(10)(b)	The applicant shall submit a letter from the appropriate municipal authority indicating the availability of central water supply.
12. 105-21(B)(12)	A map showing the location of the proposed subdivision within its neighborhood context shall be submitted.
13. 105-21(B)(13)	An Existing Resources and Site Analysis Plan (ERSAP) shall be prepared and shall provide a comprehensive analysis of existing conditions, both on the proposed development tract and within 500 feet of the tract boundaries. Conditions beyond the tract boundaries may be described on the basis of existing published data available from governmental agencies and from aerial photographs.
14. 105-21(B)(15)	The applicant shall submit a 'Preliminary Resource Impact and Conservation Plan' consistent with the requirements of this section of the ordinance.
15. 105-21(B)(17)(e) 105-22(B)(8)(b)	For all subdivision and land development applications which propose lands and/or facilities to be used or owned in common by all the residents of that subdivision or land development (collectively, the common facilities) and not deeded to the Township, the common facilities shall be controlled and maintained by a homeowners' association or condominium association (the community association) formed in accordance with all applicable laws of the Commonwealth of Pennsylvania, and governed by a community association document, also known as a "homeowners' association document" or a "condominium association document." The Community association document, if applicable, must be provided and is subject to the review and approval of the Township Solicitor.
16. 105-21.1(K)(2)	Within the South Transportation Service Area an impact fee in the amount of Two Thousand Five Hundred and Twenty-Nine Dollars (\$2,529.00) per anticipated peak hour trip must be provided by the applicant. Based on data documented within the latest edition of the ITE Trip Generation Manual, the proposed development, assesses as LUC 220 – Multifamily Housing (Low-Rise) will generate 29 PM peak hour trips. Therefore, the traffic impact fee totals \$73,341.00 (\$2,529.00 x 29 peak hour trips).
17. 105-22(B)(5)(e)	The plans must be revised to include profiles for all storm and sanitary sewer piping.
18. 105-22(B)(7), 105-79	The applicant must provide evidence of sewage facilities planning as required by Chapter 71 of the Pennsylvania Sewage Facilities Act, as amended.

	<u>Section</u>	<u>Description</u>
26.	105-38(E)	The plans must be revised to show structural components of the building in order to demonstrate access is available to each parking space, particularly in the area of 4 exterior parking spaces, and the 10 spaces which appear to have access from the porous paver egress drive.
27.	105-38(H)	Except at entrance and exit drives, all parking areas shall be set back from any property line at least 15 feet. The applicant must obtain a waiver to allow 4 parking spaces within 7 feet of the side lot line.
28.	105-38(N)	A waiver must be obtained from the requirements of this section of the ordinance, which states that the center lines of entrance and exit drives crossing the street line shall be spaced at least 80 feet apart. On all corner properties, there shall be a minimum spacing of 60 feet, measured at the street line, between the center line of any entrance or exit drive and the street line of the street parallel to said access drive. The plans show the drives to be 60± feet apart, and 30± feet from the street line. We would have no objection to the granting of this waiver, since the drives and adjacent streets are one-way only.
29.	105-38(O)	Parking areas shall be located at least 10 feet from any building or structure. The plans currently show 4 exterior parking spaces within 10 feet from the proposed structures, which must be revised or a waiver must be obtained.
30.	105-38(V), 105-21(B)(20)	All artificial lighting used to illuminate any parking space or spaces shall be so arranged that no direct rays from such lighting shall fall upon any neighboring property or streets, nor shall any high brightness surface of the luminaries be visible from neighboring residential property or from a public street. The required Lighting Plan must be revised to so as to prevent any light spill onto the adjacent residential properties.
31.	105-38(W)	Section 116-282(E) of the Zoning Code states that residential uses shall not be subject to the overflow parking requirements of this section of the Code.
32.	105-39(A)	This section of the ordinance requires that all parking areas shall have at least one tree of three inches minimum caliper for every two parking spaces provided. Calculations that demonstrate compliance with the shade tree requirements contained in this section of the ordinance must be added to the plans. The plans must be revised to indicate the caliper of all proposed trees.
33.	105-39(C)	A minimum of 10% of any parking lot facility over 2,000 square feet in gross area shall be devoted to landscaping, inclusive of required trees. The plans must be revised to meet the requirements of this section of the ordinance and the percentage of the parking lot which is devoted to landscaping must be calculated and listed on the plans.
34.	105-40(A)	Required off street loading facilities, if necessary, must be designed so that each space shall be no less than 14 feet wide, 50 feet long, and 17 feet high, exclusive of drives and maneuvering space and located entirely on the lot being served. The plans must be revised to indicate the proposed method of garbage collection and provisions must be made to provide for deliveries and moving trucks.

	<u>Section</u>	<u>Description</u>
35.	105-47(D)	Curb cuts shall be provided at all street crossings. An ADA compliant ramp and crossing should be provided across Lime Street, at the intersection with Spring Mill Avenue, and across each driveway opening.
36.	105-47(E)	This section of the ordinance states that sidewalks and pedestrian paths shall be adequately lighted, if required by the Board of Supervisors.
37.	105-47(H)	The plans must be revised in order to demonstrate compliance with the requirements of this section of the ordinance, which requires that sidewalks and pedestrian paths shall not exceed a grade of 7%. Where this is not feasible, due to natural topography, the plans should incorporate (a) level landing(s) or provide other accommodations in accordance with ADA guidelines.
38.	105-48	This section of the ordinance requires the installation of street trees along all streets where suitable trees do not exist. Large street trees shall be planted at intervals of not more than 45 feet, and/or small street trees at intervals of not more than 30 feet along both sides of new streets and along one or both sides of any existing street within the proposed land development. The plans must be revised or a waiver must be obtained.
39.	105-48(E)	A waiver would be required in order to permit the tree zone along Spring Mill Avenue and Lime Street to not be located between the sidewalk and curb.
40.	105-50(B)	The applicant must submit architectural plans including elevation views for the proposed buildings in order to demonstrate compliance with the requirements of this section of the ordinance.
41.	105-50(C)(2)	Access and circulation for fire-fighting and other emergency equipment, moving vans, fuel trucks, garbage collection, deliveries and snow removal shall be planned for efficient operation and convenience.
42.	105-50(F)(2)	The plans must be revised to indicate the proposed method of garbage collection. Garbage Collection stations, if any, shall be adequately screened and landscaped.
43.	105-52	Buffer yards are required between land developments and along existing streets to soften visual impact, to screen glare, and to create a visual barrier between conflicting land uses. The plans must be revised to provide a table detailing the buffer yard requirements, in accordance with Section 105-52.B as well as the actual buffers provided. All landscaping plans are subject to the review and approval of the Shade Tree Commission.
44.	105-52(B)(2)	This section of the ordinance requires that all buffers shall have a minimum width of 50 feet. The Board of Supervisors may permit an alternative planting option which shall have a screening capability equal to or greater than any of the available options. The applicant should provide evidence in sufficient detail to the Board of Supervisors in order to demonstrate that sufficient screening will be provided.

<u>Section</u>	<u>Description</u>
45. 105-53(D)	This section of the ordinance requires the dedication of land in the amount of 10% of the total Site Area for Park and/or Recreational use. The applicant has the option of offering a fee in lieu of dedicating actual land area and can also provide a combination of a fee in lieu and dedication of land. All offers of land and/or fees in lieu of dedication must meet the requirements of this section of the ordinance.
46. 105-56(A)(1)(a)	The width of streets has been established to ensure adequate movement of traffic in times of greater parking loads. Where a street is designed so that all units face on local streets or courts and where on-street parking is not anticipated and no safety hazard will be created, the cartway width may be reduced. This reduction is limited to 32 feet on local streets. A waiver would be required in order to allow the continuation of the existing cartway width of 30± feet for Spring Mill Avenue and Lime Street. We have no objection to the granting of this waiver, since both are one-way streets.
47. 105-69(C)	The plans must be revised to provide a half-width mill & overlay of Lime Street and Spring Mill Avenue, since the cartway edge will be disturbed in order to install new curbing. Pavement restoration above the proposed stormwater pipe in Lime Street must be at least 10 feet in width.
48. 105-71	This section of the ordinance requires that, when appropriate, the developer shall install or cause to be installed at the developer's expense metal or fiberglass pole streetlights serviced by underground conduit. The Board of Supervisors should consider requiring the installation of streetlights along the property frontages.
49. 105-72(A)	Monuments must be provided at all property line corners. Monuments shall be placed at each change in direction of a boundary along the street line; two to be placed at each street intersection and one on each side of any street at angle points and at the beginning and end of curves.
50. 105-76(B)	Water mains shall be designed with adequate capacity and appropriately spaced fire hydrants for fire-fighting purposes pursuant to the specifications of the Middle Department Association of Fire Underwriters Review, and approval by the Township Engineer and the Township Fire Marshal is required in order to ensure that adequate fire protection is provided. The applicant must obtain a letter of approval from the Township Fire Marshal.
51. 105-78	The applicant must obtain the approval of the Whitemarsh Township Authority with regard to proposed sanitary sewerage facilities.
52. 105-81	All electric, telephone and communication service facilities, both main and service lines, shall be provided by underground cables, installed in accordance with the prevailing standards and practices of the utility and other companies providing such service. Final plans shall show locations of all utilities and shall be coordinated with landscaping.
53. 105-83(E)	No Removal of a tree shall be permitted unless the applicant obtains a recommendation from the Shade Tree Commission based on a tree survey and removal plan submitted in accordance with Chapter 55 of the Whitemarsh Township Code.

<u>Section</u>	<u>Description</u>
54. 105-89	The developer shall enter into a written agreement with the Township in the manner and form approved by the Solicitor wherein the developer shall agree, to construct or cause to be constructed at his own expense all proposed improvements shown on the approved land development plan, all in strict accordance with the standards and specifications of the Township and within the time specified in said agreement, and to deposit with the Township financial security in an amount sufficient to cover the cost of all subdivision or land development improvements, including both public and private improvements.

GRADING, EROSION CONTROL, STORMWATER MANAGEMENT AND BEST MANAGEMENT PRACTICES ORDINANCE:

<u>Section</u>	<u>Description</u>
55. 58-4(B)(2)(o)	Road/Trench Restoration details must be revised to provide for the standard pavement restoration cross section for Township roads, which is 6" 25mm Superpave Base Course, 5" 25mm Superpave Binder Course, 2" 9.5mm Superpave wearing course.
56. 58-4(B)(2)(q)	The construction sequence must be revised to indicate the sequence in which site specific elements will be constructed, including retaining walls and stormwater BMPs.
57. 58-8(B)	Stormwater facilities shall be accessible to permit periodic maintenance and an access easement shall be provided to permit such access. The following blanket stormwater easement note, must be added to the plan: <i>'Stormwater facilities shall be owned and maintained by the property owner in perpetuity. The property owner shall provide a blanket stormwater access easement to the Township for the purpose of access to the stormwater facilities. If, in the judgment of the Township Engineer, the owner has failed to maintain the stormwater facilities in such a manner as to ensure their proper functioning, the Township after providing a written notice, shall have the right to enter upon the lands of the owner and to make any repairs as may be necessary to the stormwater facilities to ensure that such facilities function and perform in accordance with the design specifications. Any and all costs incurred by the Township for such repairs and/or maintenance shall be paid in full by the owner. A lien or liens may be placed against the property if the owner fails to remit payment within sixty (60) days.'</i>
58. 58-11(G)(3)	An as-built survey of all stormwater BMPs must be submitted to the Township in paper and digital (dwg) formats. A note must be added to the plans stating an as-built survey will be completed and submitted in both formats to the Township.
59. 58-11(H)(1)	The property owner shall sign an operations and maintenance agreement with the Township addressing stormwater BMPs that are to be privately owned.
60. 58-12(B)	A note must be added to the plans stating that plans for the earth disturbance activity, bearing the stamp of approval of the Township Engineer, shall be maintained at the site during the progress of the grading work and until the work has been completed.

RESOLUTION 2004-8:

<u>Section</u>	<u>Description</u>
61. I(B)(4)(g)	The stormwater BMP should be reconfigured to provide a means for encouraging stormwater to enter the stone storage area. As currently designed, stormwater may follow the path of least resistance via the pipe and bypass the stone storage area. The applicant's engineer should consider offset perforated pipes, orifices/weirs, or similar means.
62. I(B)(4)(j)	It appears that the contours in the area of the proposed exit driveway require revision to tie the proposed contour representing an elevation of 63 to the existing contour.
63. I(B)(4)(n)	A note must be added to the plans to address measures for dust control during grading.
64. I(C)(1)(b)	Detailed plans and calculations, including all factors of safety, for all of the proposed retaining walls that are prepared, signed and sealed by a professional engineer licensed in the Commonwealth of Pennsylvania must be submitted to the Township for review. Constructible details and elevation views of all proposed retaining walls as well as the top and bottom of wall elevations must be added to the plans. Fall protection must be provided, where required.
65. II(A)(8)	If in the course of reviewing the stormwater management plan, the Township Engineer determines that off-site improvements are necessary to satisfactorily control the stormwater from the site, the applicant shall be responsible for such off-site improvements.
66. II(C)(5)	The stormwater calculations must apply rainfall intensities based on NOAA rainfall data for the area.
67. II(C)(3)	This section of the ordinance required that all plans and designs for stormwater management systems and facilities submitted to the Township for approval shall determine stormwater peak discharge and runoff by use of the Soil Cover Complex (SCS) Method.
68. II(C)(8)(d)	The following note shall be attached to all drainage plans and signed and sealed by the applicant's Registered Professional Engineer experienced in geotechnical and soil engineering: <i>"I certify that the proposed facility is/is not underlain by limestone."</i>
69. II(E)(2)(g)(iv)	The applicant must obtain relief from the requirements of this section of the ordinance, which requires that all storm pipes shall be reinforced concrete pipe, in order to allow the use of high-density polyethylene (HDPE) pipe.
70. II(F)(3)(d) (4)[d]	A detailed soils evaluation of the project site shall be performed to determine the suitability of infiltration BMPs. The evaluation shall be performed by a Registered Professional Engineer experienced in geotechnical engineering or a Certified Professional Soil Scientist and at a minimum, address soil permeability, depth to bedrock, susceptibility to sinkhole formation, and subgrade stability. A copy of the results of the soils evaluation must be submitted to the Township.

<u>Section</u>	<u>Description</u>
71. II(F)(3)(d) (4)[g]	Any infiltration BMP shall be capable of completely infiltrating the impounded water within 96 hours. The applicant should verify the required infiltration is provided by the use of on site perc tests at the proposed seepage pit locations.

CHAPTER 55 - TREE PROTECTION STANDARDS

<u>Section</u>	<u>Description</u>
72. 55-4(A)	A Tree Survey Plan prepared in accordance with the requirements contained in this section of the ordinance must be submitted to the Township. The tree survey plan shall be reviewed by the Shade Tree Commission in a public meeting.
73. 55-4(A)(7)	Heritage trees and boundary trees shall be individually noted on the tree survey plan.
74. 55-4(B)(1)	The plans must be revised to include provisions for tree protection to preserve healthy trees and shrubs on site in accordance with this section of the ordinance. A note must be added to the plans requiring protective fencing to be placed around trees on the property prior to construction. Protective fencing must be shown on the plans in the areas where it will be required, and a tree protection fence detail must be provided. Street trees and other required plant material shall not be planted until the finished grading of the land development has been completed.
75. 55-4(B)(2)	A note must be added to the plans requiring a pre-construction conference with the Township Shade Tree Commission prior to start of construction.
76. 55-4(B)(6)(a)	This section of the ordinance requires that every tree determined to be living and healthy, with a DBH of 6 inches or greater and which is designated to be removed or which is destroyed, shall be replaced with one or more new shade trees of a type approved by the Township with a trunk diameter of not less than 3 inches in caliper. The total caliper of replacement trees, measured at 6 inches above the ground line, shall equal or exceed the DBH of the tree removed.
77. 55-4(B)(6)(c)	Replacement trees shall be planted in addition to the trees required by planting requirements otherwise set forth in the Subdivision and Land Development Code.

Any future submission of the design plans for this project must be accompanied by a letter, prepared by the applicant's engineer, which addresses each of the comments contained in this report. Should you have any questions regarding this matter, please do not hesitate to contact me at this office.

Sincerely,



Krista Heinrich, P.E.
Township Engineer
Gilmore & Associates, Inc.

KH/sl

cc: Mr. Charles L. Guttenplan, AICP – Director of Planning and Zoning
Mr. Sean Kilkenny, Esq.; The Law Offices of Sean Kilkenny, LLC – Township Solicitor (*via email*)
Mr. Sean Halbom – Assistant Township Manager
Mr. Robert A. Sztubinski, B.C.O. – Director of Building & Codes (*via email*)
Mr. Nick Weaver – Fire Marshal (*via email*)
Mr. Chuck Borkowski– Applicant
931 Spring Mill Avenue LLC– Owner of Record
Mr. John B. Anderson, PE– Applicant's Engineer

O:\MUNICIPAL\2021\2105094-WshT_561 Spring Mill Ave S-LD 02-21\correspondence\Review #1.doc

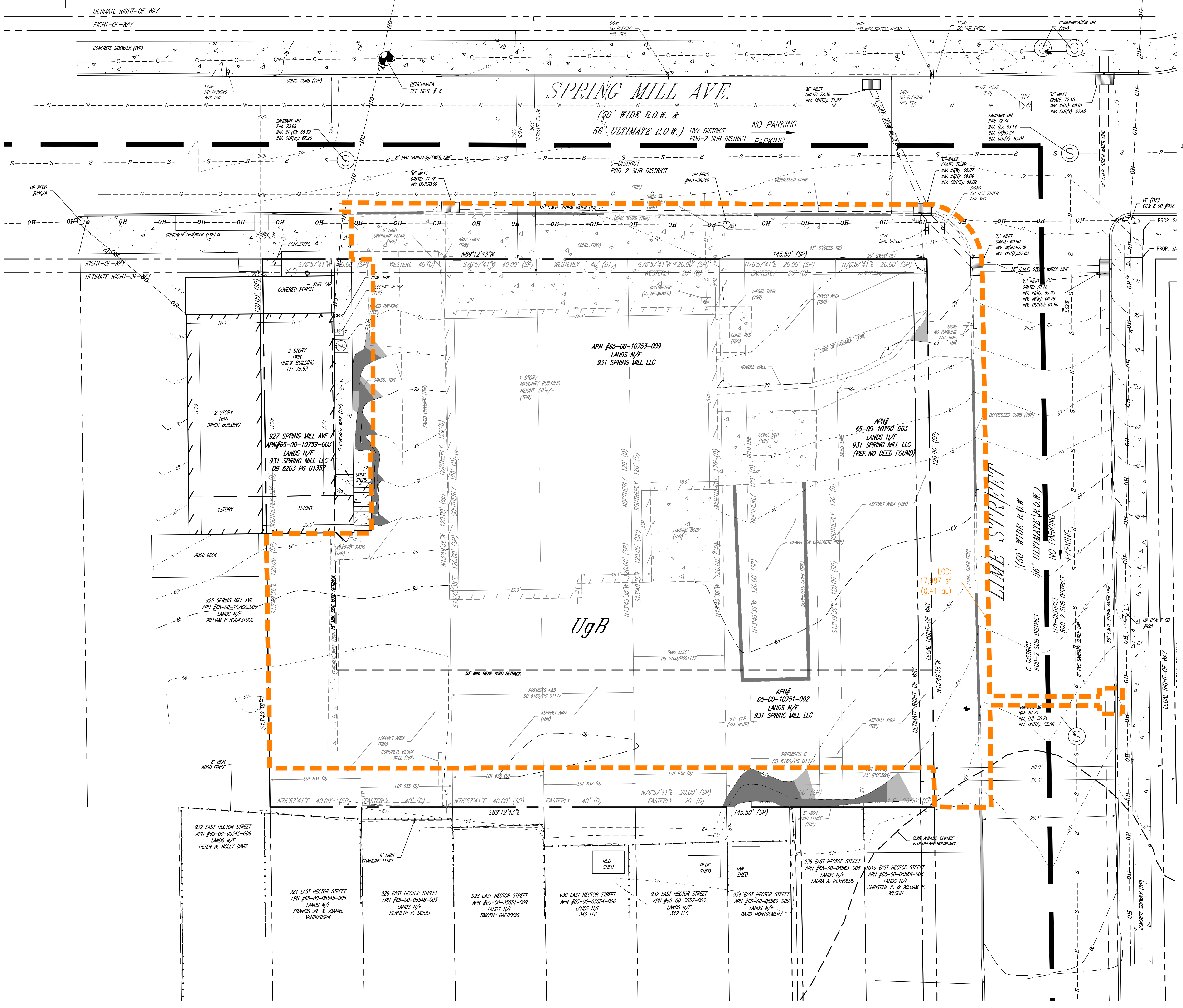

LEGEND & ABBREVIATIONS

- PROPERTY BOUNDARY
- - - ADJOINER BOUNDARY
- - - RIGHT OF WAY LINE
- - - BUILDING SETBACK LINE
- - - EXISTING CONTOUR
- - - EXISTING SPOT ELEVATION
- - - EXISTING TREE LINE
- - - MUNICIPAL BOUNDARY
- - - EXISTING FENCE
- - - EXISTING OVERHEAD WIRE
- - - APPROXIMATE GAS LINE
- - - APPROXIMATE WATER LINE
- - - APPROXIMATE TELCO LINE
- - - APPROXIMATE ELECTRIC LINE
- - - APPROXIMATE SANITARY LINE
- - - APPROXIMATE DRAINAGE LINE
- - - EXISTING CURB
- - - EXISTING DEPRESSED CURB (DC)
- - - EXISTING SIGN
- - - EXISTING UTILITY POLE (UP)
- - - CONDUIT - TRANSFORMER
- - - LIGHT - METER - BOX
- - - GUY WIRE
- - - LANDSCAPE AREA
- - - LAMP POST
- STORM MANHOLE
- SANITARY MANHOLE
- COMMUNICATION MANHOLE
- ELECTRIC MANHOLE
- WATER MANHOLE
- UNKNOWN MANHOLE
- TANK LID
- STORM INLET
- GAS METER
- WATER METER
- TRAFFIC SIGNAL BOX
- ELECTRIC VAULT
- GAS VALVE
- WATER VALVE
- CLEAN OUT
- MONITORING WELL
- CONCRETE MONUMENT FOUND
- IRON PIN FOUND
- IRON PIPE FOUND
- NAIL FOUND
- STONE FOUND
- BENCHMARK
- (D) DEED
- TBR TO BE REMOVED

STEEP SLOPES KEY

- 15-25% GRADE
- 25%+ GRADE

STEEP SLOPES CALCULATIONS

\$116-169.B STEEP SLOPE OVERLAY
LIMIT OF DISTURBANCE: 17,987 SF (0.41 AC)

	TOTAL AREA WITHIN PARCEL	TOTAL AREA PERMITTED TO BE REGRADED	TOTAL AREA PROPOSED TO BE REGRADED
15-25% SLOPES	78 SF	30% (23 SF)	12% (9 SF)
25%+ SLOPES	216 SF	15% (32 SF)	14% (31 SF)

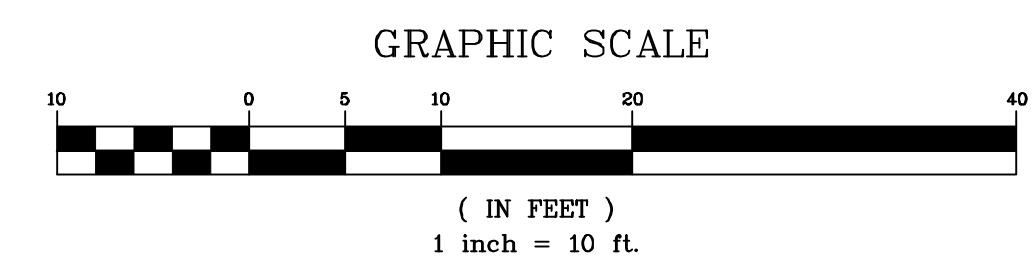

Cornerstone
Consulting Engineers & Architectural, Inc.

213 West Main Street, Lansdale, PA 19446
Phone: 215-362-2600, Fax: 215-362-8400
WWW.CORNERSTONEINC.COM

Pennsylvania Region
910-839-1770

Philadelphia Region
215-362-2600

REVISIONS

NO.	BY	DESCRIPTION	DATE
1	EMR	REVISED PER TOWNSHIP COMMENTS	3-4-22

PENNSYLVANIA ONE CALL SYSTEM, INC.
923 Iron Run Road
West Mifflin, Pennsylvania 15122-1078

BEFORE YOU DIG ANYWHERE IN PENNSYLVANIA CALL 1-800-242-1776
SN: 30210471243

NON-MEMBERS MUST BE CONTACTED DIRECTLY
PA LAW REQUIRES THREE WORKING DAYS NOTICE TO UTILITIES BEFORE YOU EXCAVATE, DRILL, BLAST OR DEMOLISH.

J.B. ANDERSON
PROFESSIONAL ENGINEER
P.E. License No. PE 13483
P.E. License No. PE 095536
P.E. License No. PE 09113
NEW JERSEY LICENSE No. 24664510400
VIRGINIA LICENSE No. 680156252

PROJECT LOCATION

BORKOWSKI HOMES PRESENTS WESTY PROJECT

931 SPRING MILL AVENUE, LLC
927-31 SPRING MILL AVENUE
WHITEMARSH TOWNSHIP
MONTGOMERY COUNTY
COMMONWEALTH OF PENNSYLVANIA

TITLE

STEEP SLOPES PLAN

PROJ. #	21-0231	DATE	12-30-2021
CAD ID.	21-0231	DRN BY	EMR
SCALE	AS NOTED	CHK BY	JBA

SHEET 4 OF 12

REVISION 1

March 4, 2022

Whitemarsh Township Municipal Building
616 Germantown Pike
Lafayette Hill, PA 19444

Attn: Township Board of Supervisors

1. RE: Westy Project
Spring Mill Avenue &
Lime Street
Whitemarsh Township
Montgomery County, PA

Board of Supervisors:

As a part of the Preliminary/Final Land Development plan submission package, please accept this letter as a formal waiver request for the above referenced project. Our office, on behalf of the applicant, Borkowski Homes, respectfully requests the following waivers from the Board of Supervisors.

- 1. §105-29(C) & 105-30(A) Spring Mill Ave and Lime Street are classified as local streets. Local streets require a 50 ft. (ultimate) right-of-way, a 36 ft cartway, curbs, sidewalks, and a tree zone.**

A waiver from the above section is being requested to not require the existing cartways of Spring Mill Avenue and Lime Street to be widened from 30 ± ft wide to 36 ± ft to keep the width consistent with the existing roadway.

- 2. §105-35(C) No structure shall be maintained between a plane two feet above the curb level and a plane seven feet above curb level so as to interfere with traffic visibility across the corner with that part of the required front yard which is within the clear sight triangle. Clear sight triangles shall include the area bounded by any two intersecting street lines and a straight line drawn between points on each such line 50 feet from the intersection of said lines or extensions thereof.**

A waiver from the above section is being requested to allow the proposed building to be built to the intersection of the right-of-ways. Spring Mill Ave and Lime St are both one-

We're with you through Every Step of development.

way streets and therefore do not need a sight triangle on the southwest corner of the intersection. The proposed construction will not create an obstructed view of this corner.

- 3. §105-48 Street trees are required to be planted along all streets where suitable street trees do not exist.**

A waiver from the above section is being requested to not require street trees on Spring Mill Ave. Planting trees along Spring Mill Ave would be in conflict with existing stormwater pipes and inlets, overhead wires and underground utilities along the subject side of the street. The applicant is acceptable to alternatives to the required locations and is willing to discuss the issue with the Board.

- 4. §105-38(A) Minimum dimensions for 90° parking aisles is 24 feet in width.**

A waiver from the above section is being requested to permit 22 foot-wide, one-way aisles for 90 degree parking. It has been accepted in surrounding communities that parking structures can be allotted a reduction in the required driveway aisle widths from 24' to 22' in width due to the nature of the development.

- 5. §105-38(b) Minimum width of entrance and exit drives shall be 25 ft for two-way use.**

The proposed entrance and exit for the parking area is intended to maintain one-way circulation, therefore a waiver from the above section may not be required.

- 6. §105-38(H) Except at entrance and exit drives, all parking areas shall be set back from the right-of-way line and all property lines at least 15 feet.**

A waiver from the above section is being requested to permit one parking space within 7 feet of the side lot line behind the twin structure. The one parking space is a minor encroachment into this area and the applicant can add additional screening around the perimeter to mitigate the impacts.

- 7. §105-38(N) For the purpose of servicing any property held under single and separate ownership, entrance and exit drives crossing the street line shall be limited to two along the frontage of any single street, and their center lines shall be spaced at least 80 feet apart. On all corner properties, there shall be a minimum spacing of 60 feet, measured at the street line, between the center line of any entrance or exit drive and the street line of the street parallel to said access drive.**

A waiver from the above section is being requested to permit the drives to be 60± feet apart and 30± feet from the street line. In order to provide adequate circulation throughout the parking area, two access drives area required for the development.

It is the developer's intent to comply with all Township requirements, however, it is their opinion that strict conformance with the noted ordinance sections above would create unnecessary impacts to the proposed development of the site. The applicant respectfully requests the aforementioned waivers to be granted for the proposed development.

Should you have any questions or concerns please do not hesitate to contact our office.

Sincerely,

2. Cornerstone Consulting
Engineers & Architectural, Inc.



John B. Anderson, P.E.

Cc: Chuck & Natalie Borkowski – Applicant

SUPERSEDED

March 15, 2022

Whitemarsh Township Municipal Building
616 Germantown Pike
Lafayette Hill, PA 19444

Attn: Township Board of Supervisors

RE: Westy Project
Spring Mill Avenue &
Lime Street
Whitemarsh Township
Montgomery County, PA

Board of Supervisors:

As a part of the Preliminary/Final Land Development plan submission package, please accept this letter as a formal waiver request for the above referenced project. Our office, on behalf of the applicant, Borkowski Homes, respectfully requests the following waivers from the Board of Supervisors.

- 1. §105-29(C) & 105-30(A) Spring Mill Ave and Lime Street are classified as local streets. Local streets require a 56 ft. (ultimate) right-of-way, a 36 ft cartway, curbs, sidewalks, and a tree zone.**

A waiver from the above section is being requested to not require the existing cartways of Spring Mill Avenue and Lime Street to be widened from 30 ± ft wide to 36 ± ft to keep the width consistent with the existing roadway.

- 2. §105-35(C) No structure shall be maintained between a plane two feet above the curb level and a plane seven feet above curb level so as to interfere with traffic visibility across the corner with that part of the required front yard which is within the clear sight triangle. Clear sight triangles shall include the area bounded by any two intersecting street lines and a straight line drawn between points on each such line 50 feet from the intersection of said lines or extensions thereof.**

A waiver from the above section is being requested to allow the proposed building to be built to the intersection of the right-of-ways. Spring Mill Ave and Lime St are both one-

We're with you through Every Step of development.

Land Development ♦ Engineering ♦ Architecture ♦ Land Surveying ♦ Construction Management

www.cornerstonenet.com

way streets and therefore do not need a sight triangle on the southwest corner of the intersection. The proposed construction will not create an obstructed view of this corner.

3. §105-37 Minimum sight distance requirements must be provide as indicated in the ordinance.

Spring Mill Ave and Lime St are both one-way streets away from the subject property and therefore do not need a sight triangle on the southwest corner of the intersection. The proposed construction will not create an obstructed view of this corner.

4. §105-38(A) Minimum dimensions for 90° parking aisles is 24 feet in width.

A waiver from the above section is being requested to permit 22 foot-wide, one-way aisles for 90 degree parking. It has been accepted in surrounding communities that parking structures can be allotted a reduction in the required driveway aisle widths from 24' to 22' in width due to the nature of the development.

5. §105-38(B) Minimum width of entrance and exit drives shall be 25 ft for two-way use.

The proposed entrance and exit for the parking area is intended to maintain one-way circulation, therefore a waiver from the above section may not be required.

6. §105-38(H) Except at entrance and exit drives, all parking areas shall be set back from the right-of-way line and all property lines at least 15 feet.

A waiver from the above section is being requested to permit one parking space within 7 feet of the side lot line behind the twin structure. The one parking space is a minor encroachment into this area and the applicant can add additional screening around the perimeter to mitigate the impacts.

7. §105-38(N) For the purpose of servicing any property held under single and separate ownership, entrance and exit drives crossing the street line shall be limited to two along the frontage of any single street, and their center lines shall be spaced at least 80 feet apart. On all corner properties, there shall be a minimum spacing of 60 feet, measured at the street line, between the center line of any entrance or exit drive and the street line of the street parallel to said access drive.

A waiver from the above section is being requested to permit the drives to be 60± feet apart and 30± feet from the street line. In order to provide adequate circulation throughout the parking area, two access drives area required for the development.

- 8. §105-39(C) A minimum of 10% of any parking lot facility over 2,000 sf in gross area shall be devoted to landscaping, inclusive of the required trees.**

A waiver of the required 10% landscaping area is requested due to the proposed parking is located under the building. Landscaping has been provided around the perimeter of the access drives, but cannot be provided in the interior of the parking field.

- 9. §105-56(A)(1)(a) The width of streets has been established to ensure adequate movement of traffic in times of greater parking loads. Where a street is designed so that all units face on local streets or courts and where on-street parking is not anticipated and no safety hazard will be created, the cartway width may be reduced. This reduction is limited to 36 feet on minor collectors, 32 feet on local streets and 26 feet on private streets and courts.**

A waiver is requested to allow the continuation of the 30' cartway on Spring Mill Avenue and Lime Street. The existing streets are one-way in movement and additional widening in a limited section of both roadways does not seem to be warranted.

- 10. §II(E)(2)(g)(iv) All storm pipes shall be reinforced concrete pipe.**

A waiver is requested to allow the use of High Density Polyethylene Pipe in lieu of Reinforced Concrete Pipe. The plan proposes an underground detention basin that will need to utilize perforated pipe. RCP is not manufactured as a perforated pipe and HDPE has been widely accepted as a suitable alternative with competent structural properties and resistance to corrosion that provides a longer lifespan.

It is the developer's intent to comply with all Township requirements, however, it is their opinion that strict conformance with the noted ordinance sections above would create unnecessary impacts to the proposed development of the site. The applicant respectfully requests the aforementioned waivers to be granted for the proposed development.

Should you have any questions or concerns please do not hesitate to contact our office.

Sincerely,

**1. Cornerstone Consulting
Engineers & Architectural, Inc.**

A handwritten signature in black ink, appearing to read 'JBA', written in a cursive style.

John B. Anderson, P.E.

cc: Natalie and Chuck Borkowski
Charles Guttenplan, AICP
Krista Heinrich, PE

March 15, 2022

Mr. Richard L. Mellor, Jr., Township Manager
Whitemarsh Township Municipal Building
616 Germantown Pike
Lafayette Hill, PA 19444

Attn: Township Board of Supervisors

RE: Westy Project
Spring Mill Avenue &
Lime Street
Whitemarsh Township
Montgomery County, PA

Dear Mr. Mellor,

We have received your review letter dated February 4, 2022. We offer the following responses in support of the Preliminary/Final Land Development Application:

Zoning Ordinance Compliance Review Letter, February 3, 2022

1. §116-11. The ultimate rights-of-way for Spring Mill Avenue and Lime Street are shown at 56 feet as required by code.
2. §116-14. The Zoning District Boundary lines have been added and the C-Residential Zoning District line has been shown along the centerline of Spring Mill Ave and Lime Street.
3. §116-21. As discussed with staff, the location of the building and associated improvements will not obstruct the view at the intersection of Spring Mill Ave and Lime Street. Both roadways in this area are one-way streets with a direction of travel that east and south and thus does not have a sight triangle for motorists in a north west direction.
4. §116-22.A note has been added to the plan which states that the permanent removal of topsoil from land within the Township is prohibited.
5. §116-24.D(3) The plan has been revised to eliminate 3 parking spaces within the 30' rear yard of the parcel. However, one parking space and an area for trash containers still remains within the rear yard. The area between the rear lot line and the rear building plane comprises of 5,090 sf and the parking space and trash area cover 257 sf. This results in a 5% encroachment in the rear yard area which is permitted.
6. §116-28.A.(2) The applicant will obtain the required will serve letters for the project.
7. §116-29. The applicant will obtain approval of the Whitemarsh Township Authority for the sanitary sewer discharge.
8. §116-33.D As discussed with staff, the location of the building and associated improvements will not obstruct the view at the intersection of Spring Mill Ave and Lime Street.
9. §116-169.B The plan set has been revised to include areas of steep slopes that exist on the property. Also included in the set is a steep slope encroachment plan that shows the amount of steep slopes that will be impacted by the proposed development. The calculations show that the proposed encroachment does not exceed the allowable disturbances and thus the plan is in compliance with the zoning code.

We're with you through Every Step of development.

10. §116-184.G. Our office is in receipt of the Fire Marshal's review letter that indicates a fire hydrant must be located with 600' of the proposed building. A fire hydrant has been added to the plan to show compliance and we will work with the Fire Marshal for specific placement.
11. §116-187. The plan provides for adequate temporary loading and unloading with the drive aisle to the south of the building. Also, the plan has been revised to show a trash container area for the use of the residents.
12. §116-188.3 The plans have been revised to show two (2) Electric Vehicle charging stations as required. One of the two spaces is proposed to be accessible.
13. §116-205,208,209,210,286. The applicant does not include signage at this time, however, any signage proposed will be in accordance with the zoning ordinances.
14. §116-281.B.(3) The zoning table includes the existing twin structure that is incorporated in the consolidated parcel.
15. §116.281.B.(3)(b) The zoning table has been revised to include the lot width of the Lime Street Frontage.
16. §116.281.B.(3)(h) An impervious surface calculation has been added to the site plan. The plan has also been revised to eliminate the pervious pavers and the driving surface has been changed to asphalt. The impervious surface calculation confirms that the project is at or below the allowable 75% max impervious allowance.
17. §116-282.A The applicant will provide information for the design of the building showing compliance of the zoning requirement.
18. §116-283., 116-287.B.(2) The applicant will provide additional building elevations in order to show compliance of the zoning ordinances.
19. §116-283.A.(6) All HVAC units will be mounted on the roof of the structure.
20. §116-283.C.(1) Street Trees will be provided in accordance with SALDO Section 105-48 or a waiver will be requested.
21. §116-283.C.(2)(b) As stated previously the southwest corner of the intersection does not have a required sight triangle due to the direction of travel for both streets.
22. §116-283.D The applicant intends to comply with the pedestrian-oriented development standards and will discuss specific requirements with the Planning Commission.

A deed of consolidation will be filed with the record documents upon approval of the project.

Subdivision and Land Development Ordinance

1. The zoning district boundary lines have been added to the record plans.
2. The plans have been revised to include the size of the units.
3. Adjoining property boundaries and names of landowners across Spring Mill Avenue and Lime Street have been added to the plans.
4. The location map has been revised to be shown at 800 feet equals 1 inch.
5. Proposed monumentation has been added to the plans. No existing monumentation was found during the survey.
6. An aerial plan has been added to the submission to depict the surrounding features within 500 feet of the project location.
7. A steep slope plan has been added to the submission
8. Existing trees over 6" cal. have been added to the plans
9. It is acknowledged that the Township Planning Commission may request the preparation of a traffic planning study.
10. A sanitary sewer letter will be provided.
11. A water capacity letter will be provided.
12. Location maps have been provided in the plan set.
13. An Existing Resources and Site Analysis Plan (ERSAP) and an Aerial plan has been added to the submission to depict the surrounding features within 500 feet of the project location.
14. An Existing Resources and Site Analysis Plan (ERSAP) and an Aerial plan has been added to the submission to depict the surrounding features within 500 feet of the project location.
15. The apartment development will be controlled and maintained by a rental management company, therefore, a condo association will not be required.

16. The applicant will provide the traffic impact fee.
17. Profiles for the storm and sanitary sewer piping have been added to the submission.
18. A sewer planning exemption is being sought and will be provided to the Township once received.
19. Street trees will be provided along both street frontages in accordance with Township requirements.
20. The retaining wall has been located outside of the ultimate right-of-way, however a waiver is required due to the placement of the building at the intersection of the road rights-of-way.
21. Sight distance dimensions are not required due to the configuration and traffic flow of the intersection.
22. Sight distance dimensions are not required due to the configuration and traffic flow of the intersection.
23. A waiver is being requested to permit a 22± foot-wide one-way aisle. Pavement markings and signs have been added to reinforce the one-way directional pattern.
24. A waiver is being requested to permit a 22± foot-wide one-way entrance and exit.
25. A turning plan has been revised to demonstrate that a vehicle is able to navigate the turns within the parking structure.
26. The plans have been revised to show additional structural components of the building.
27. A waiver is being requested to permit one parking space within 7 feet of the side lot line.
28. A waiver is being requested to permit the drives to be less than 80 feet apart and less than 60 feet from the street line.
29. The parking has been revised to locate parking areas 10 feet away from the proposed building.
30. The lighting plan has been revised to prevent light spill over onto the adjacent residential properties.
31. No response required.
32. The landscape plan has been revised to indicate the caliper of all proposed trees
33. A waiver is being requested or an interpretation that due to the structured parking, the 10% landscape area is not required.
34. Off-street loading is provided within the exiting drive aisle of the parking area. Also, a trash collection area has been provided at the rear of the parking area.
35. An ADA compliant ramp and crossing have been added at the intersection of Spring Mill Ave and Lime St.
36. Additional lighting will be added if required by the Board of Supervisors.
37. The plans have been revised to comply with the ADA requirements.
38. Street trees have been shown along both road frontages. We will work with the Township and staff on the locations and species of the plantings due to potential conflicts with utilities.
39. Street trees have been shown along both road frontages. We will work with the Township and staff on the locations and species of the plantings due to potential conflicts with utilities.
40. Architectural plans and elevations will be provided.
41. Vehicular access as required in the review comment has been provided on the turning plan.
42. A trash collection area has been provided at the rear of the parking area. The enclosure is proposed to be a 5ft high wooden fence.
43. A compliance charts has been added to the Landscape Plans detailing the buffer requirements.
44. An alternative screening option is being proposed within the landscaping plan to show compliance.
45. The applicant will provide a fee in-lieu of providing dedicated land for Park and/or Recreational use.
46. A waiver is being requested to not require the existing cartway of Spring Mill Avenue and Lime Street to be widened from 30 ± ft wide to 36 ± ft to keep the width consistent with the existing conditions.
47. A half-width mill & overlay of Lime St and Spring Mill Ave will be provided. Full depth pavement restoration of 10 feet wide will be provided above the proposed stormwater pipe in Lime St.
48. Additional lighting and electrical conduit for the same will be added if required by the Board of Supervisors.
49. Proposed monumentation has been added to the plans.
50. A water capacity letter will be provided, as will a letter of approval from the Township Fire Marshal.
51. A sanitary sewer capacity letter will be provided from the Township Authority.
52. Utilities will be provided and shown in accordance with all applicable codes and laws.
53. Trees proposed for removal will be replaced according to the applicable ordinances.
54. The applicant will enter into a developer's agreement with the Township for proposed improvements.
55. The road/trench restoration details have been revised.
56. The construction sequence has been revised.
57. A blanket access easement will be provided for the proposed stormwater facilities. A note will be added to the plans.

58. An as-built survey for the stormwater BMPs will be provided to the Township. A note will be added to the plans accordingly.
59. The property owner will sign an operations and maintenance agreement with the Township for stormwater BMPs
60. A note has been added to the plans regarding the earth disturbance activity.
61. The stormwater design has been revised.
62. The grading has been revised per the comment.
63. A note has been added to address dust control measures during grading.
64. A construction detail has been added for the 0-4 ft landscape wall proposed along Lime St.
65. No response required.
66. Stormwater calculations used were derived from NOAA rainfall data.
67. It is being requested that the Township Engineer grant the stormwater facilities be designed using the rational method due to the small scale of the project.
68. A note will be added to the plans.
69. A waiver is being requested to permit the use of HDPE pipe instead of reinforced concrete pipe (RCP).
70. A geotechnical investigation regarding soils evaluation for infiltration will be provided as part of the resubmission of the plans.
71. A geotechnical investigation regarding soils evaluation for infiltration will be provided as part of the resubmission of the plans.
72. A tree survey has been included with the plans.
73. Heritage trees and boundary trees have been noted on the plans.
74. Tree protection fencing will be provided as required.
75. A note indicating that a pre-construction meeting is required prior to earth disturbance.
76. A tree survey has been included with the plans. Tree replacement as required has been included in the landscaping compliance chart.
77. Replacement trees have been included in the compliance chart and will be in addition to other planting requirements.

Fire Marshal Review Letter, January 10, 2022

1. Based on our review there are no fire hydrants within 600' of the proposed development. The plans have been revised to provide a fire hydrant along Spring Mill Avenue.

Montgomery County Planning Commission Review Letter, February 3, 2022

1.
 - a. The parking area is located under the building and therefore the 1st floor of living space of the building will be raised above the proposed parking. We are not proposing double stacked parking without access to an access aisle. The parking has been revised to address the comments of the staff review and compliance with impervious cover constraints.
 - b. ADA Spaces have been included in the parking layout.
 - c. Electric Vehicle Charging Spaces have been included in the parking layout.
2.
 - a. The plan has been revised to add a landscaping strip along both road frontages.
 - b. Street Trees have been provided as required along both street frontages.
3.
 - a. Additional trees have been included in the rear buffer area as suggested.
 - b. Additional planting species has been included to provide diversity in the planting program.

The aforementioned changes have been included in the plan set with the exception of the SALDO Waivers as indicated. A separate Waiver Request letter has been provided detailing the waiver request. Thank you for your assistance in the review of the project and should you have any questions or comments, please contact our office.

Sincerely,

**Cornerstone Consulting
Engineers & Architectural, Inc.**

A handwritten signature in black ink, appearing to read 'J.B.A.', written in a cursive style.

John B. Anderson, P.E.

cc: Natalie and Chuck Borkowski
Charles Guttenplan, AICP
Krista Heinrich, PE

WHITEMARSH TOWNSHIP

To: Charles Guttenplan, AICP, Director of Planning and Zoning

From: SEAN HALBOM, ASST. TOWNSHIP MANAGER

Subject: **Summary of Shade Tree Commission Meeting: 4/5/2022: 931 Spring Mill Road (SLD# 01-22)**

Date: April 6, 2022

Mr. Halbom shared there was one commission abstention from this project, Ms. Borkowski.

The applicant, Chuck Borkowski presented and shared the plans that stressed native species. He added that the site is blighted at present moment, so they wished to add green space as an improvement. Mr. Hosbach shared that there were no trees being removed from this property. Mr. Halbom shared that this project's landscaping plans have no requirements under Chapter 55; however, some Chapter 105 (sub-division and land development) requirements did apply.

Mr. Halbom shared the applicant has agreed to update their plans to include 3" caliper trees, as required by Chapter 105-39(a), specifically the Eastern Redbud and Flowering Dogwood.

Mr. Kaufman asked if the replacement species were native. Chair Ziegler replied he saw many. Mr. Fassbender asked John to opine, and he replied he was pleased with it. As far as the trees, the Dogwood and Redbud are native. Mr. Halbom shared that the nativity requirements in chapter 55 were not at play here since these are trees required by the SALDO.

Ms. Paultis offered public comment stating that the Arborvitae were a non-native species.

Chair Ziegler motioned to accept the plans with the size substitutions, Mr. Fassbender seconded the motion. The motion passed 3-0, with Ms. Borkowski abstaining.

Sean Halbom, MPA
Assistant Township Manager
616 Germantown Pike
Lafayette Hill, PA 19444
Phone: 610-825-3535 ext. 2604
Email: shalbom@whitemarshwp.org